



eSure™ Power Extend Converter & +27 VDC Vertiv™ eSure™ Bullet Converter Mounting Bracket Kit

Installation Manual

Kit Specification Number: 565460

The information contained in this document is subject to change without notice and may not be suitable for all applications. While every precaution has been taken to ensure the accuracy and completeness of this document, Vertiv assumes no responsibility and disclaims all liability for damages resulting from use of this information or for any errors or omissions. Refer to other local practices or building codes as applicable for the correct methods, tools, and materials to be used in performing procedures not specifically described in this document.

The products covered by this instruction manual are manufactured and/or sold by Vertiv. This document is the property of Vertiv and contains confidential and proprietary information owned by Vertiv. Any copying, use or disclosure of it without the written permission of Vertiv is strictly prohibited.

Names of companies and products are trademarks or registered trademarks of the respective companies. Any questions regarding usage of trademark names should be directed to the original manufacturer.

Technical Support Site

If you encounter any installation or operational issues with your product, check the pertinent section of this manual to see if the issue can be resolved by following outlined procedures.

Visit <https://www.vertiv.com/en-us/support/> for additional assistance.

TABLE OF CONTENTS

Admonishments Used in this Document	iv
Important Safety Instructions	v
Safety Admonishments Definitions.....	v
Safety and Regulatory Statements.....	v
Déclarations de Sécurité et de Réglementation.....	v
1 Vertiv™ eSure™ Power Extend Converter & +27 VDC Vertiv™ eSure™ Bullet Converter Mounting Bracket Kit Installation Instructions	1
1.1 Kit Description.....	1
1.2 Tools and Material Required.....	1
1.3 Mounting Bracket Kit Contents.....	2
1.4 Mounting Bracket Kit Installation Procedure.....	3
1.4.1 Important Safety Instructions.....	3
1.4.2 Installing Bracket Kit P/N 565460.....	3
2 Installing the Converter into a Distribution Position	8
2.1 Important Safety Instructions.....	8
2.2 Restrictions.....	8
2.3 Single Converter Installation – Top Row.....	9
2.4 Parallel Converter Installation – Top Row.....	14
2.5 Single Converter Installation – Bottom Row.....	20
2.6 Parallel Converter Installation – Bottom Row.....	25

Admonishments Used in this Document



DANGER! Warns of a hazard the reader **will** be exposed to that will **likely** result in death or serious injury if not avoided. (ANSI, OSHA)



WARNING! Warns of a potential hazard the reader **may** be exposed to that **could** result in death or serious injury if not avoided. This admonition is not used for situations that pose a risk only to equipment, software, data, or service. (ANSI)



CAUTION! Warns of a potential hazard the reader **may** be exposed to that **could** result in minor or moderate injury if not avoided. (ANSI, OSHA) This admonition is not used for situations that pose a risk only to equipment, data, or service, even if such use appears to be permitted in some of the applicable standards. (OSHA)



ALERT! Alerts the reader to an action that **must be avoided** in order to protect equipment, software, data, or service. (ISO)



ALERT! Alerts the reader to an action that **must be performed** in order to prevent equipment damage, software corruption, data loss, or service interruption. (ISO)



FIRE SAFETY! Informs the reader of fire safety information, reminders, precautions, or policies, or of the locations of fire-fighting and fire-safety equipment. (ISO)



SAFETY! Informs the reader of general safety information, reminders, precautions, or policies not related to a particular source of hazard or to fire safety. (ISO, ANSI, OSHA)

Important Safety Instructions

Safety Admonishments Definitions

Definitions of the safety admonishments used in this document are listed under “Admonishments Used in this Document” on page iv.

Safety and Regulatory Statements

Refer to Section 4154 (provided with your customer documentation) for Safety and Regulatory Statements.

Déclarations de Sécurité et de Réglementation

Reportez-vous à la Section 4154 (fourni avec les documents de votre client) pour les déclarations de sécurité et de réglementation.

This page intentionally left blank.

1 Vertiv™ eSure™ Power Extend Converter & +27 VDC Vertiv™ eSure™ Bullet Converter Mounting Bracket Kit Installation Instructions

1.1 Kit Description

Mounting bracket kits have been designed to easily install the Vertiv™ eSure™ Power Extend Converter (Model C48/58-1000B, Spec. No. 1C48581000B) or the +27 VDC Vertiv™ eSure™ Bullet Converter (Model C48/27-375B, Spec. No. 1C4827375B) into a distribution position of a Vertiv™ NetSure™ Power System (see UM565050 or UM60147273 for kit part numbers and descriptions). A mounting bracket kit must be used for grounding and mechanical support. See Table 1.1 for the kits covered by these instructions.

These instructions provide a step-by-step procedure to field install the Vertiv™ eSure™ Power Extend Converter or the +27 VDC Vertiv™ eSure™ Bullet Converter using the kit listed in Table 1.1. Installation of this kit in other systems not listed in Table 1.1 should not be attempted.

Table 1.1 Power System Mounting Bracket Kit Covered by these Instructions

Mounting Bracket Kit P/N	Description
565460	For use with a Spec. No. 582137000 List 27 power system.

1.2 Tools and Material Required

Table 1.2 lists the items required to install this kit.

Table 1.2 Tools and Material Required

Description
#2 Phillips Blade Screw Driver, insulated, 14" long shaft minimum
Torque Wrench, insulated (capable of being set from 9.6 in-lbs to 72 in-lbs)
3/8" Drive Ratchet and Socket Set, insulated
Power Extend Converter Kit (P/N 565050) (Model C48/58-1000B, Spec. No. 1C48581000B) or +27 VDC Vertiv™ eSure™ Bullet Converter Kit (P/N 60147273) (Model C48/27-375B, Spec. No. 1C4827375B), quantity as needed

1.3 Mounting Bracket Kit Contents

Table 1.3 lists the items furnished as a part of the mounting bracket kit covered by these instructions. Before installing a mounting bracket kit, check the items furnished against those listed to ensure that there are no shortages.

Table 1.3 Mounting Bracket Kit P/N 565460 Contents

P/N	Description	Qty.
565682	Left Side Mounting Bracket	1
565683	Right Side Mounting Bracket	1
565684	Front Mounting Bracket	1
132101	#10 Captive Nut (factory attached to left/right brackets)	2
218706400	#10-32 x 5/8" Screw (factory attached to left/right brackets)	2
214108200	#10 Flat Washer (factory attached to left/right brackets)	2
120412	#6-19 x 5/16" Screw (factory attached to left/right brackets)	2
152223	Retaining Washer (factory attached to left/right brackets)	2
152175	Hot Surfaces Caution Label (factory attached to front bracket)	2
60010906	Panel Position Label, 30-Pos	2
151950	Storage Pouch	2
552423	Hook-and-Loop Fastener (factory attached to storage pouch)	2
566026	Toggle Breaker Guard Kit, includes... (Qty. 27) L-Shaped Guard Brackets (Qty. 27) #6-32 x 3/16" Screws (Qty. 27) M3-0.5 x 5 mm Screws	1
565460IB	Instructions (IM565460)	1

1.4 Mounting Bracket Kit Installation Procedure

THESE INSTRUCTIONS SHOULD BE READ THROUGH COMPLETELY BEFORE INSTALLING THE KIT.

The following is a step-by-step procedure to install the kit. The procedure has been written for ease of use and to minimize the possibility of contact with potentially hazardous energy. This procedure should be performed in the sequence given, and each step should be completely read and fully understood before performing that step. Observe all “Important Safety Instructions” starting on page v and also those presented in the following procedure. As each step of the procedure is completed, the box adjacent to the respective step should be checked. This will minimize the possibility of inadvertently skipping any steps. If the step is not required to be performed for your site, also check the box to indicate that it was read.

1.4.1 Important Safety Instructions



DANGER! Adhere to the “Important Safety Instructions” starting on page v and those listed in the power system manual.



CAUTION! When performing any step in procedures that requires removal or installation of hardware, use caution to ensure no hardware is dropped and left inside the unit; otherwise service interruption or equipment damage may occur.



NOTE! When performing any step in this procedure which requires removal of existing hardware, retain all hardware for use in subsequent steps, unless otherwise stated.

1.4.2 Installing Bracket Kit P/N 565460

- [] 1. Performing this procedure may activate external alarms. Do one of the following. If possible, disable these alarms. If these alarms cannot be easily disabled, notify the appropriate personnel to disregard any future alarms associated with this system while the procedure is being performed.
- [] 2. Gain access to the distribution panel into which the converter is to be installed.
- [] 3. Remove the plastic shield from the **TOP** distribution panel by loosening the screws securing it. Slide the shield up and out to remove it. The shield will not be reused. See Figure 1.1.

Figure 1.1 Remove Shield from Top Distribution Panel

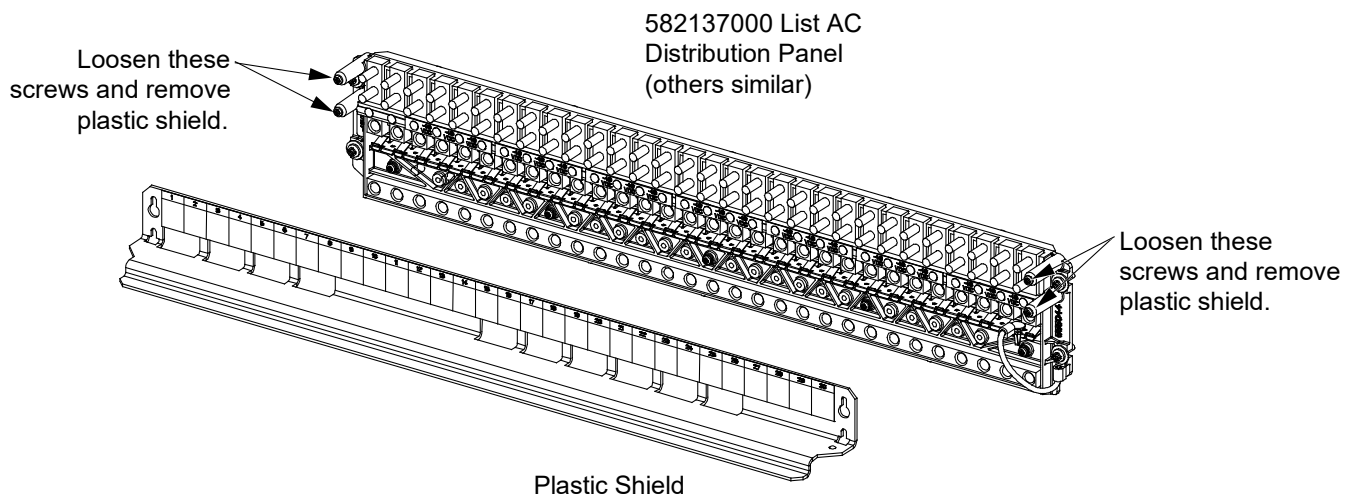

- [] 4. Completely remove the four (4) screws (two per side) that secured the shield to the **TOP** distribution panel. Save two (2) screws for later re-assembly. See Figure 1.2.

Figure 1.2 Remove Screws from Top Distribution Panel

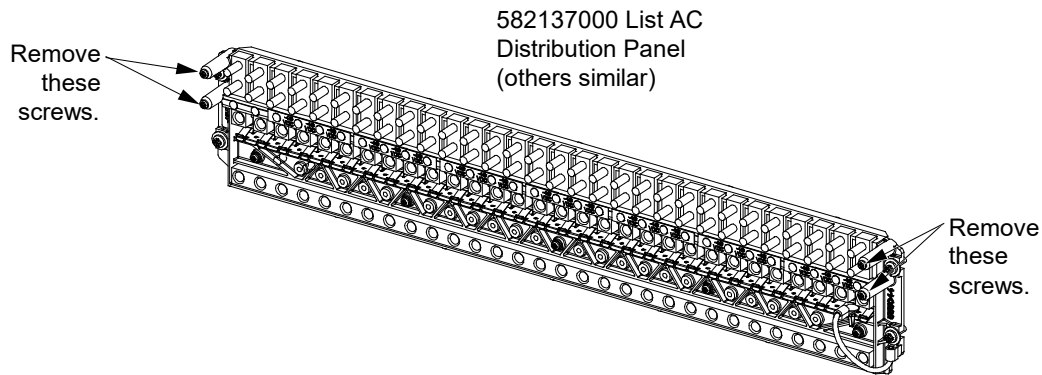

- [] 5. Remove the bottom two (2) screws and flat washers (one per side) that secures the **TOP** distribution panel to the cabinet. These will not be reused. See Figure 1.3.

Figure 1.3 Remove Screws from Top Distribution Panel

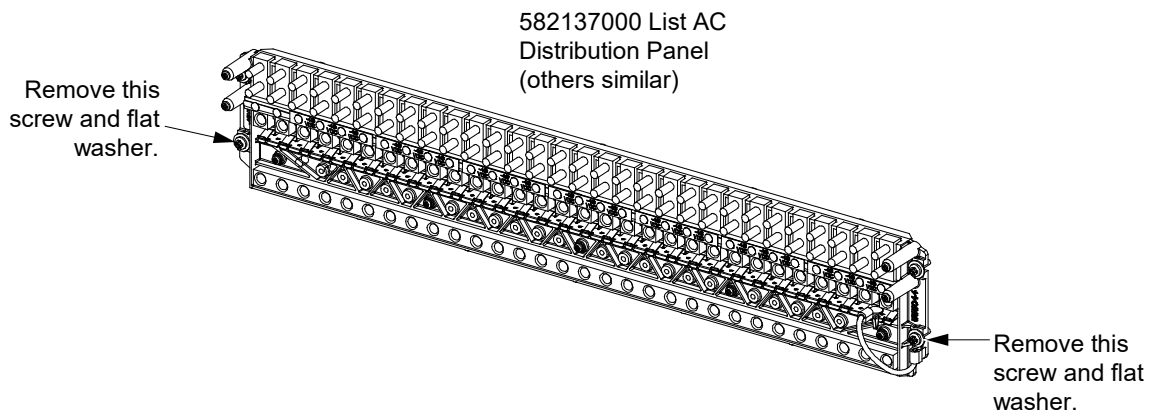

- [] 6. Orient the kit supplied left side mounting bracket as shown in Figure 1.4 (top distribution panel). Note that the bracket comes preassembled with mounting hardware. Slide the mounting bracket into position and secure with the captive hardware. Re-assemble the screw saved in [] 4. above. Torque all hardware as indicated in Figure 1.4.

Figure 1.4 Install Left Side Mounting Bracket

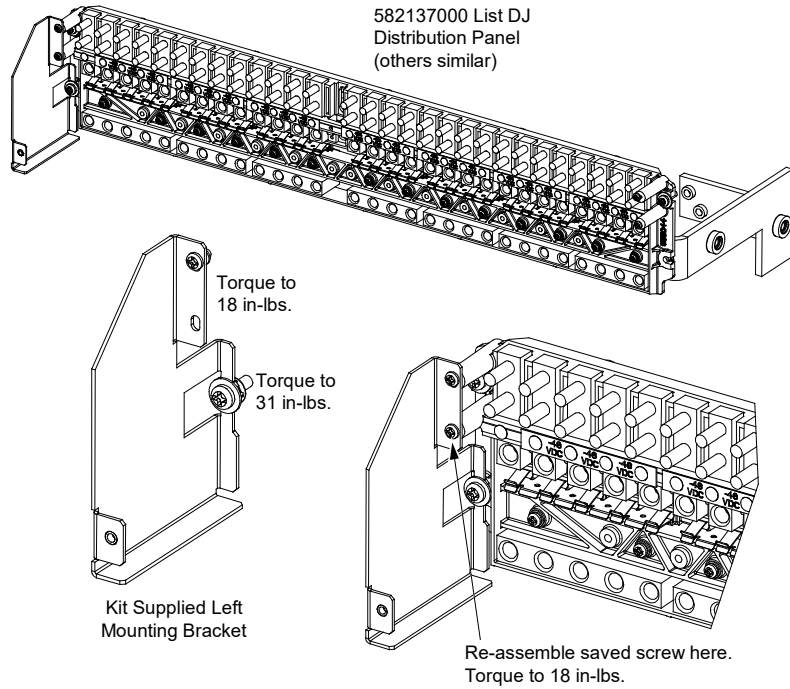

- [] 7. Orient the kit supplied right side mounting bracket as shown in Figure 1.5 (top distribution panel). Note that the bracket comes preassembled with mounting hardware. Slide the mounting bracket into position and secure with the captive hardware. Re-assemble the screw saved in [] 4. above. Torque all hardware as indicated in Figure 1.5.

Figure 1.5 Install Right Side Mounting Bracket

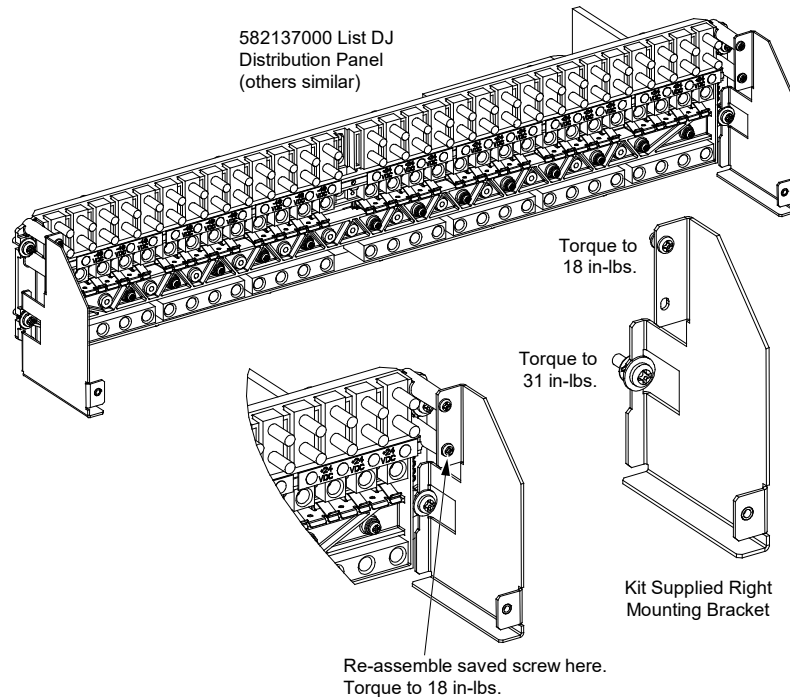

- [] 8. Orient the kit supplied front mounting bracket as shown in Figure 1.6 (top distribution panel). Note that the bracket comes preassembled with mounting hardware. Secure the front bracket to the left and right brackets by tightening the captive fasteners. Torque hardware as indicated in Figure 1.6.

Figure 1.6 Install Front Mounting Bracket

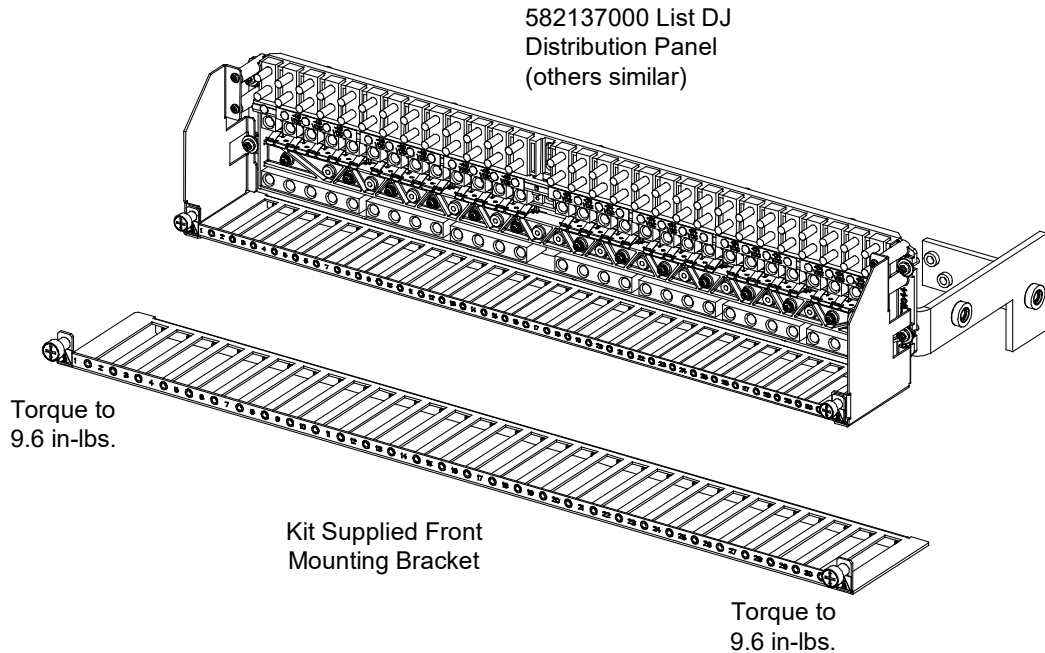

- [] 9. If the bottom distribution panel is to be populated with converter(s), remove the plastic shield from the bottom distribution panel by loosening the screws securing it. Slide the shield up and out to remove it. The shield will not be reused. Tighten or remove the screws that secured the shield to the bottom distribution panel. See Figure 1.1.
- [] 10. Remove one of the kit supplied distribution position labels (see Figure 1.7) from one of the kit supplied storage pouches and (using the plastic shield removed from the top distribution panel as a guide) record the distribution positions onto the kit supplied label.
- [] 11. Place the kit supplied distribution position label (see Figure 1.7) back into the kit supplied storage pouch or remove the backing from the label and adhere it to a suitable surface near the power system. If the kit supplied distribution position label is placed back into the storage pouch, remove the backing from the hook-and-loop fastener factory attached to the storage pouch and adhere the storage pouch to a suitable surface near the power system.
- [] 12. Repeat the above steps with the second storage pouch and label if the bottom distribution panel is to be populated with converter(s).

Figure 1.7 Distribution Position Label

Distribution Position Label

 VERTIV™		ROW 2 <input type="checkbox"/>	ROW 4 <input type="checkbox"/>
		ROW 1 <input type="checkbox"/>	ROW 3 <input type="checkbox"/>
POS.	DETAIL	POS.	DETAIL
1		16	
2		17	
3		18	
4		19	
5		20	
6		21	
7		22	
8		23	
9		24	
10		25	
11		26	
12		27	
13		28	
14		29	
15		30	

- [] 13. Install the toggle breaker guard kit (P/N 566026) as required per site requirements. See Figure 1.8.

Figure 1.8 Toggle Breaker Guard Kit (P/N 566026)

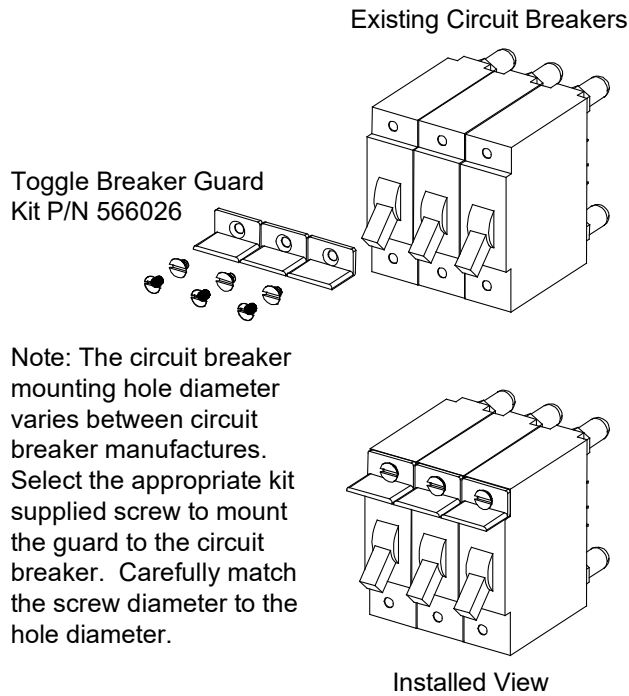

- [] 14. Continue with the next procedure to install the converter.

2 Installing the Converter into a Distribution Position

2.1 Important Safety Instructions



DANGER! Adhere to the “Important Safety Instructions” starting on page v and those listed in the power system manual.



ALERT! Only install the converter into a -48 VDC or -58 VDC distribution position. Non-repairable damage will occur if the converter is plugged into a +24 VDC distribution position.



NOTE! The converter can be inserted or removed with power applied (hot swappable) as long as the converter is inserted/removed with the enable/disable switch in the disabled position (see Figure 2.4 on page 12).



WARNING! The converter and front mounting bracket becomes very hot during converter operation at heavy load. Wear heat resistant gloves or allow the converter to cool down before removing.



NOTE! It is recommended that the +27 VDC Vertiv™ eSure™ Bullet Converters be installed in the side of the panel opposite from where the larger breakers are recommended to be installed to minimize heat concentration.

2.2 Restrictions

Refer to the converter instruction manual (UM565050 or UM60147273) for wire sizing restrictions.

For the Power Extend Converter, refer to Table 2.1 for spacing and power restrictions. This table shows how many converters can be placed side by side before skipping a single space at certain average power levels and in specific distribution row positions. These power levels pertain to the average output power (busy hour average power) drawn by the load including any power loss in the cable. The peak power available from each unit remains at 1000 watts regardless of spacing or location. Use the calculator tool that can be obtained at <https://www.vertiv.com/en-us/products-catalog/critical-power/dc-power-systems/esure-power-extend-converter-c4858-1000/#/downloads> to determine the necessity, quantity and spacing requirement of the Power Extend Converter based on the RRU type (or peak load), use application (host power system), trunk and jumper cable size and length, minimum source voltage and minimum RRU operating voltage.

Table 2.1 eSure™ Power Extend Converter Spacing and Power Restrictions: Spec. No. 582137000 List 27 Operating in a Vertiv™ OSP Cabinet Spec. No. F2012504, F2015053, F2016064

Distribution Row	Watts Per Power Extend Converter				
	No Spaces	1 Pole / Space	2 Pole / Space	3 Pole / Space	4 Pole / Space
Row 1 Only	350 W	800 W	700 W	500 W	400 W
Rows 1 and 2	250 W	550 W	500 W	325 W	300 W
Row 2 Only	400 W	800 W	700 W	550 W	500 W

Note: Row 1 is the Bottom Row

For the +27 VDC Vertiv™ eSure™ Bullet Converter, no spacing is required between units. A total of three (3) units can be paralleled together for a total output power of 750 W at 40 °C and 600 W at 65°C. It is recommended that the +27 VDC Vertiv™ eSure™ Bullet Converters be installed in the side of the panel opposite from where the larger breakers are recommended to be installed to minimize heat concentration. As an example, for the Spec. No. 582137000 power system, the larger breakers for the - 58 VDC output in the top distribution row are recommended to be installed on the right-hand side of the panel. Therefore, the +27 VDC Vertiv™ eSure™ Bullet Converter is recommended to be installed on the left-hand side of the panel.

2.3 Single Converter Installation – Top Row

To parallel converters in the top row, refer to the procedure “Parallel Converter Installation – Top Row” starting on page 14.

Procedure

- [] 1. Move the grounding tab from the top of the converter to the bottom per Figure 2.1.

Figure 2.1 Moving Grounding Tab from Top of Unit to Bottom

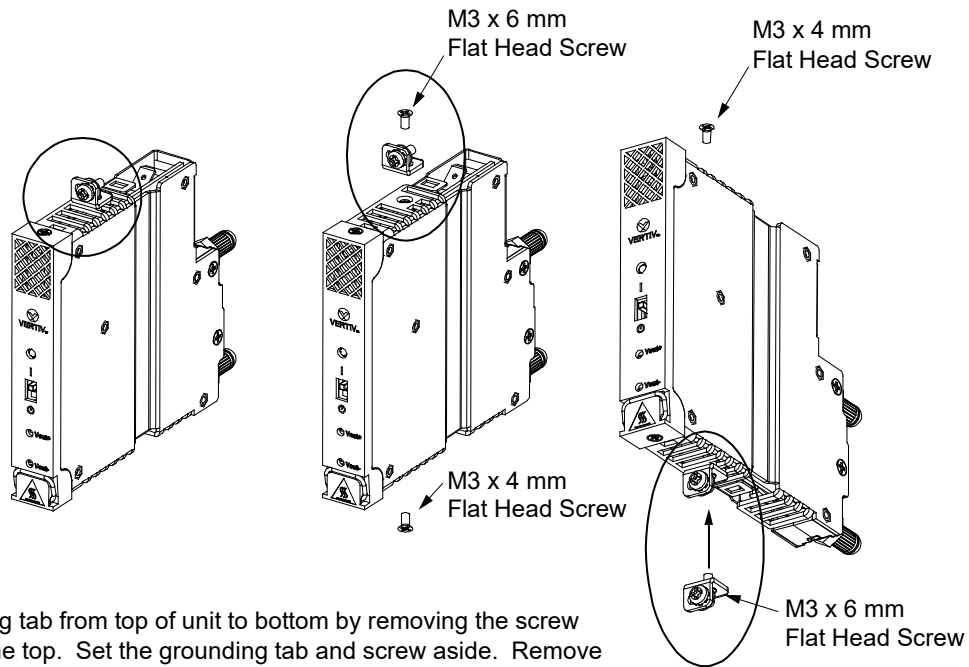

Move grounding tab from top of unit to bottom by removing the screw securing it to the top. Set the grounding tab and screw aside. Remove the bottom screw. Secure the screw removed from the bottom location into the top location (note that it is a different length than the screw used to secure the grounding tab). Orient the grounding tab in the bottom location as shown in the illustration and secure with the screw removed from the top location (longer screw). Torque both screws to 5.8 in-lbs.

- [] 2. If the converter is to be installed for a newly connected load, connect the load and load return cables to the distribution position to be occupied by the converter. The connection for the load cable can be one of the busbar lug landing points directly behind the converter or to the positive side of the terminal block on the +27 VDC Bullet Nose 6-Position GMT Fuse Board (only used with the +27 VDC Vertiv™ eSure™ Bullet Converter). The connection for the return lead can be on the Return bar of the plant or the negative side of the terminal block on the +27 VDC Bullet Nose 6-Position GMT Fuse board. At the same time, connect the converter return wire faston tab provided with the converter to the cabinet's return busbar (if present, use the same location as the return lead to the load). At the same time (if required), connect the separately ordered converter paralleling busbar to the distribution panel load busbars using the same location as the load lead to the load. If two or three converters are to be connected in parallel or if a +27 VDC Bullet Nose 6-Position GMT Fuse Board Kit (10062803) is used along with the converters, a two-position (60016097), three-position (545346), four-position (10078650), or five-position (10078651) lug adapter busbar plate should be installed first, as shown in the installation instructions in UM10062803. See Figure 2.2 and Figure 2.19. Torque hardware as indicated in Figure 2.2.

- [] 3. If the converter is to replace an existing circuit breaker, remove the circuit breaker and verify the load and return cables for the position are wired and labeled correctly. At the same time, connect the converter return wire faston tab provided with the converter to the cabinet's return busbar (use the same location as the return lead to the load). At the same time (if required), connect the separately ordered converter paralleling busbar to the distribution panel load busbars (using the same location as the load lead to the load). If two or three converters are to be connected in parallel, a two-position (60016097), or three-position (545346), or four-position (10078650), or five-position (10078651) lug adapter busbar plate should be installed first. See Figure 2.2 and Figure 2.19. Torque hardware as indicated in Figure 2.2.

NOTE! The following images show two- and three-position lug adapter busbar plates. Four- and five-position adapter plates are also available and are installed similarly.

Figure 2.2 Connecting Converter Load and Load Return Cables, Installing Converter Return Wire Faston Tab

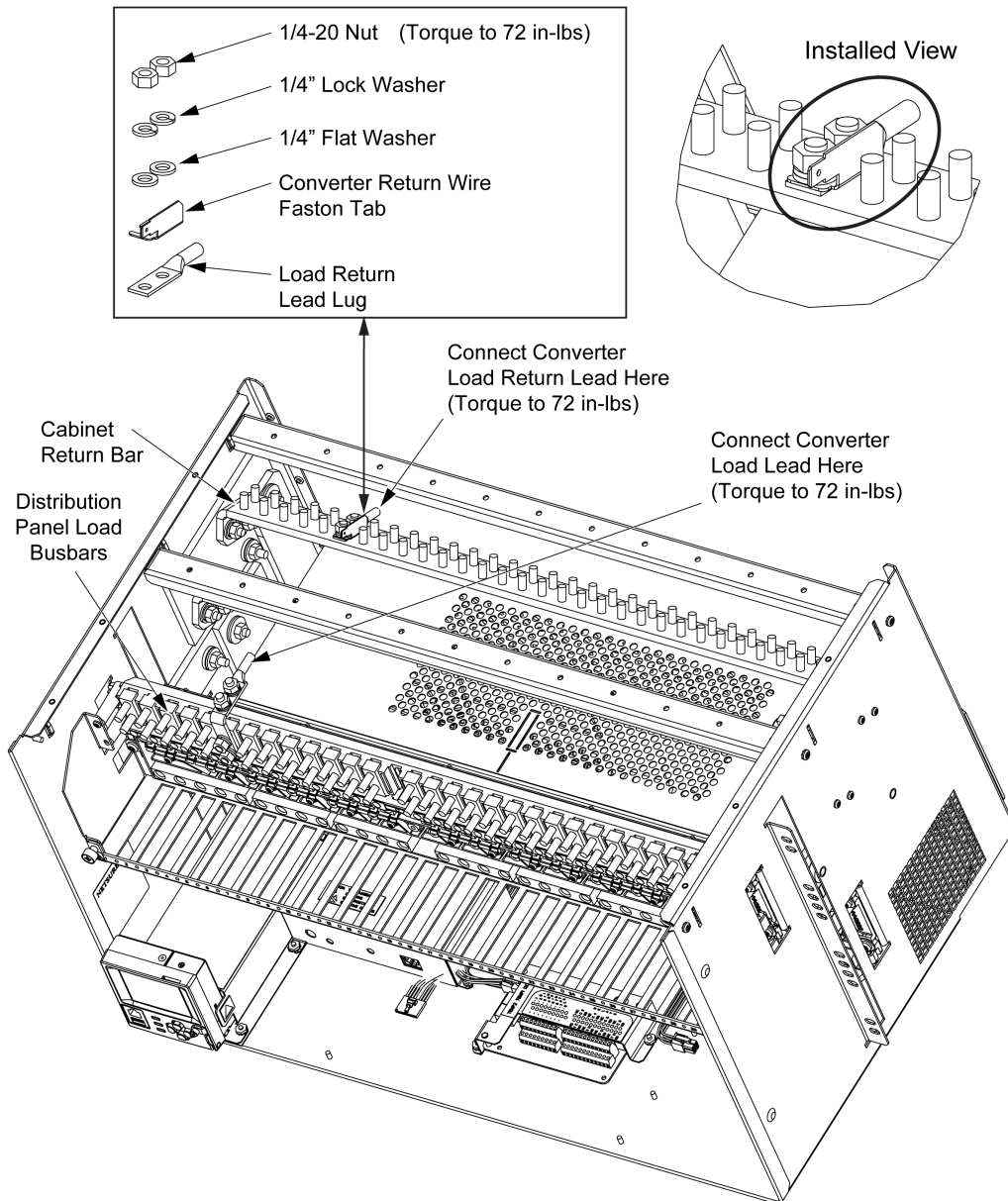

- [] 4. Connect the return wire (P/N 564330) and 4-inch long return wire jumper (P/N 565752) provided with the converter to the converter return wire faston tab installed on the cabinet's return bar in the step above. See Figure 2.3.



NOTE! The converter is also furnished with an 8-inch long return wire jumper P/N 566207. The 8-inch long return wire jumper is not used with this mounting bracket kit. It is used in other kits.

- [] 5. Route the return wire (P/N 564330) as shown in Figure 2.3, then connect it to the converter. Orient the white square on the return wire faston receptacle's locking tab as shown in Figure 2.3.

Figure 2.3 Connecting Converter Return Wire (P/N 564330) and Return Wire Jumper (P/N 565752)

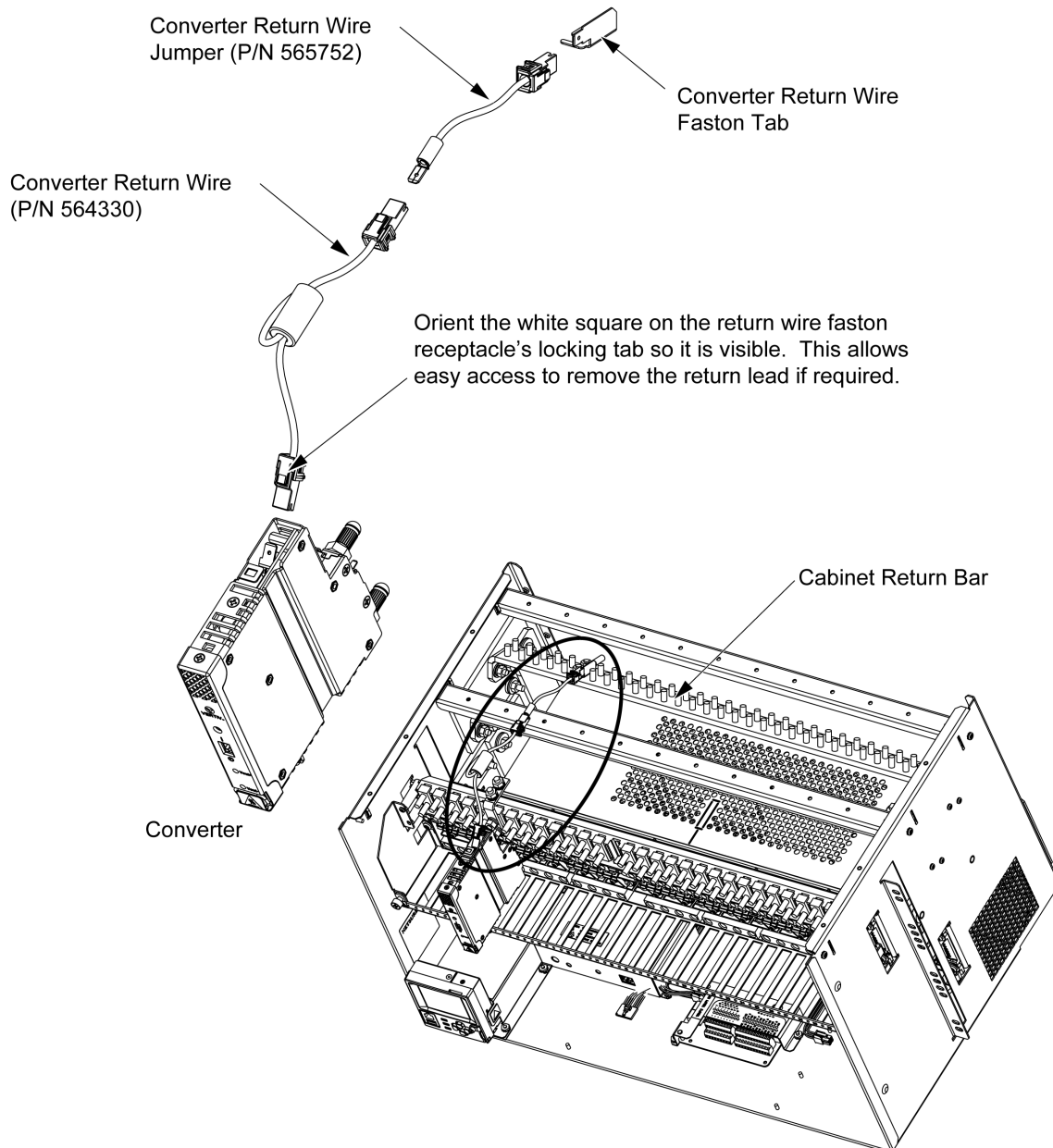

- [] 6. Ensure the enable/disable switch on the converter is in the disable (down) position. See Figure 2.4.

Figure 2.4 Enable/Disable Switch

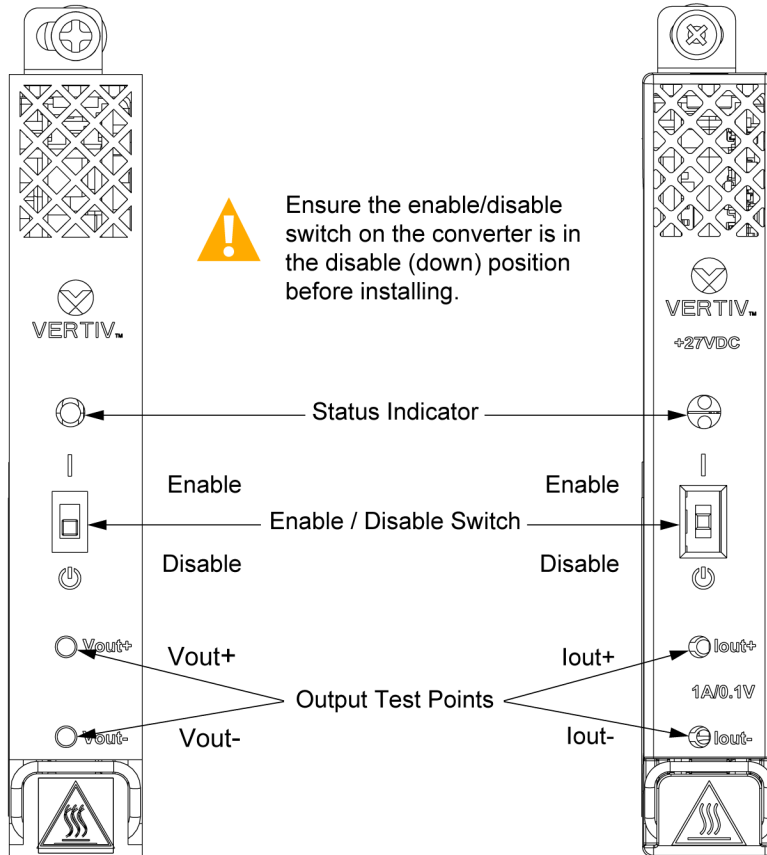

Note: Output Voltage measurement on the +27 VDC Vertiv™ eSure™ Bullet Converter represents output current. 1A/0.1V

- [] 7. Plug the converter into the distribution panel. See Figure 2.5.
- [] 8. Secure the converter to the front mounting bracket with the screw provided with the converter. Torque hardware as indicated in Figure 2.5.
- [] 9. Place the enable/disable switch on the converter to the enable position. See Figure 2.4.
- [] 10. Observe the status of the converter front panel local indicator. If operating normally, this indicator should be illuminated green. See Figure 2.4.
- [] 11. Enable the external alarms or notify appropriate personnel that this procedure is finished.
- [] 12. Ensure that there are no local or remote alarms active on the power system.

Figure 2.5 Installing Converter

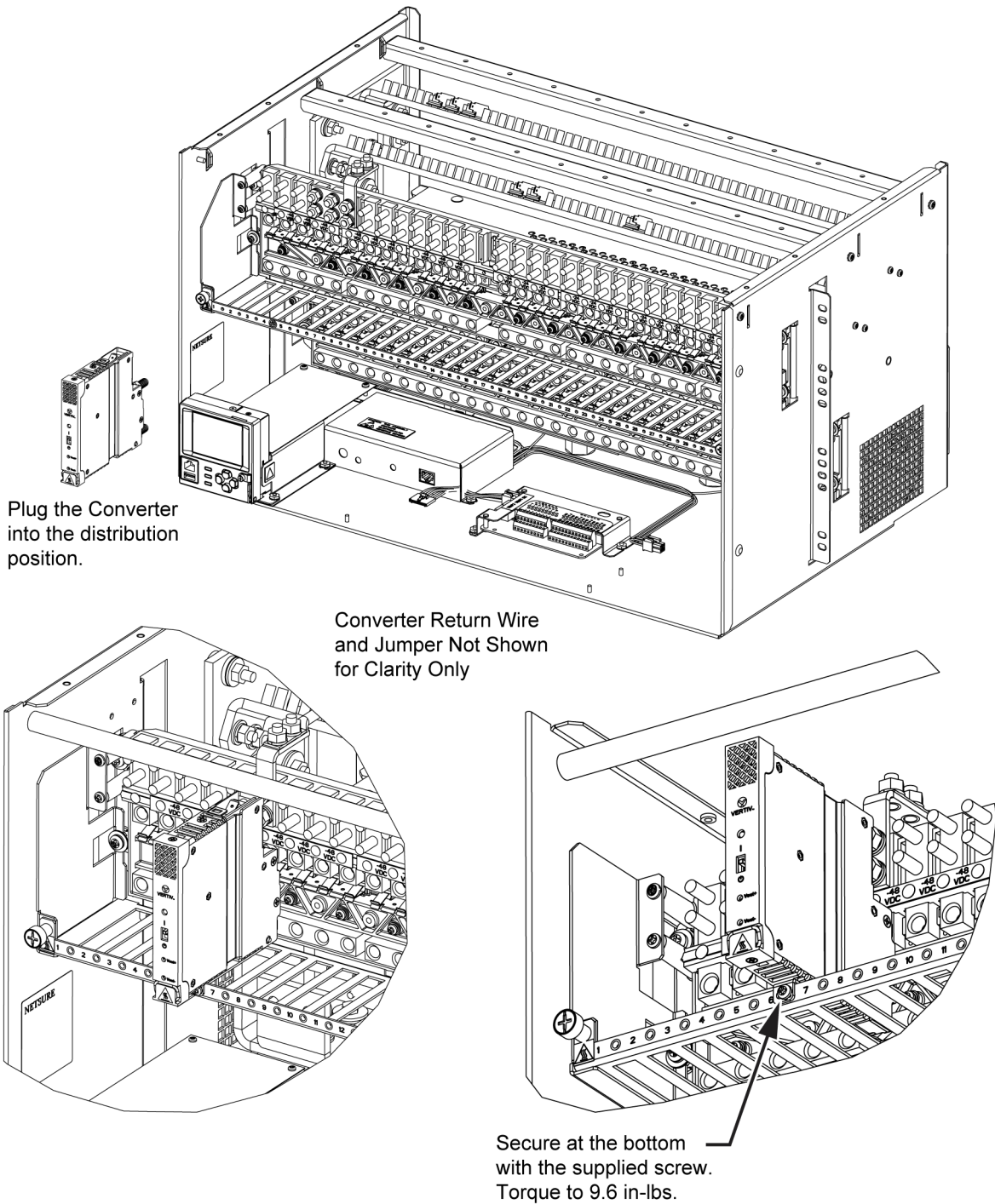

2.4 Parallel Converter Installation – Top Row

To install a single converter in the top row, refer to the procedure “Single Converter Installation – Top Row” starting on page 9.

Procedure

- [] 1. Move the grounding tab from the top of the converter to the bottom per Figure 2.6.

Figure 2.6 Moving Grounding Tab from Top of Unit to Bottom

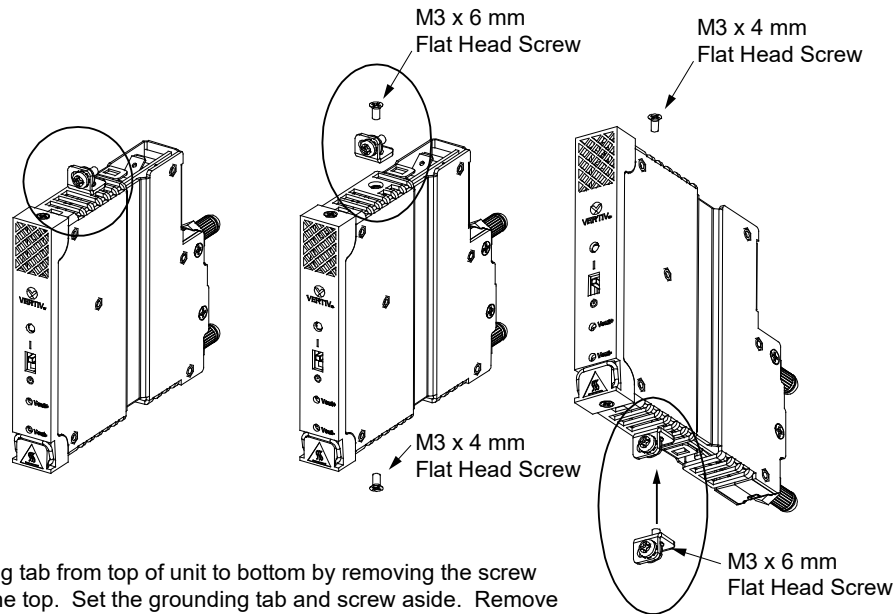

Move grounding tab from top of unit to bottom by removing the screw securing it to the top. Set the grounding tab and screw aside. Remove the bottom screw. Secure the screw removed from the bottom location into the top location (note that it is a different length than the screw used to secure the grounding tab). Orient the grounding tab in the bottom location as shown in the illustration and secure with the screw removed from the top location (longer screw). Torque both screws to 5.8 in-lbs.

- [] 2. If the converter is to be installed for a newly connected load, connect the load and load return cables to the distribution position to be occupied by the converter. The connection for the load cable can be one of the busbar lug landing points directly behind the converter or to the positive side of the terminal block on the +27 VDC Bullet Nose 6-Position GMT Fuse Board (only used with the +27 VDC Vertiv™ eSure™ Bullet Converter). The connection for the return lead can be on the Return bar of the plant or the negative side of the terminal block on the +27 VDC Bullet Nose 6-Position GMT Fuse board. At the same time, connect the converter return wire faston tab provided with the converter to the cabinet's return busbar (if present, use the same location as the return lead to the load). At the same time (if required), connect the separately ordered converter paralleling busbar to the distribution panel load busbars using the same location as the load lead to the load. If two or three converters are to be connected in parallel or if a +27 VDC Bullet Nose 6-Position GMT Fuse Board Kit (10062803) is used along with the converters, a two-position (60016097), three-position (545346), four-position (10078650), or five-position (10078651) lug adapter busbar plate should be installed first, as shown in the installation instructions in UM10062803. See Figure 2.7 and Figure 2.19. Torque hardware as indicated in Figure 2.7.

- [] 3. If the converter is to replace an existing circuit breaker, remove the circuit breaker and verify the load and return cables for the position are wired and labeled correctly. At the same time, connect the converter return wire faston tab provided with the converter to the cabinet's return busbar (use the same location as the return lead to the load). At the same time (if required), connect the separately ordered converter paralleling busbar to the distribution panel load busbars (using the same location as the load lead to the load). If two or three converters are to be connected in parallel, a two-position (60016097), or three-position (545346), or four-position (10078650), or five-position (10078651) lug adapter busbar plate should be installed first. See Figure 2.7 and Figure 2.19. Torque hardware as indicated in Figure 2.7.

NOTE! The following images show two- and three-position lug adapter busbar plates. Four- and five-position adapter plates are also available and are installed similarly.

Figure 2.7 Connecting Converter Load and Load Return Cables, Installing Converter Return Wire Faston Tab, Installing Paralleling Busbar (P/N 60016097 or 545346) (cont'd on next page)

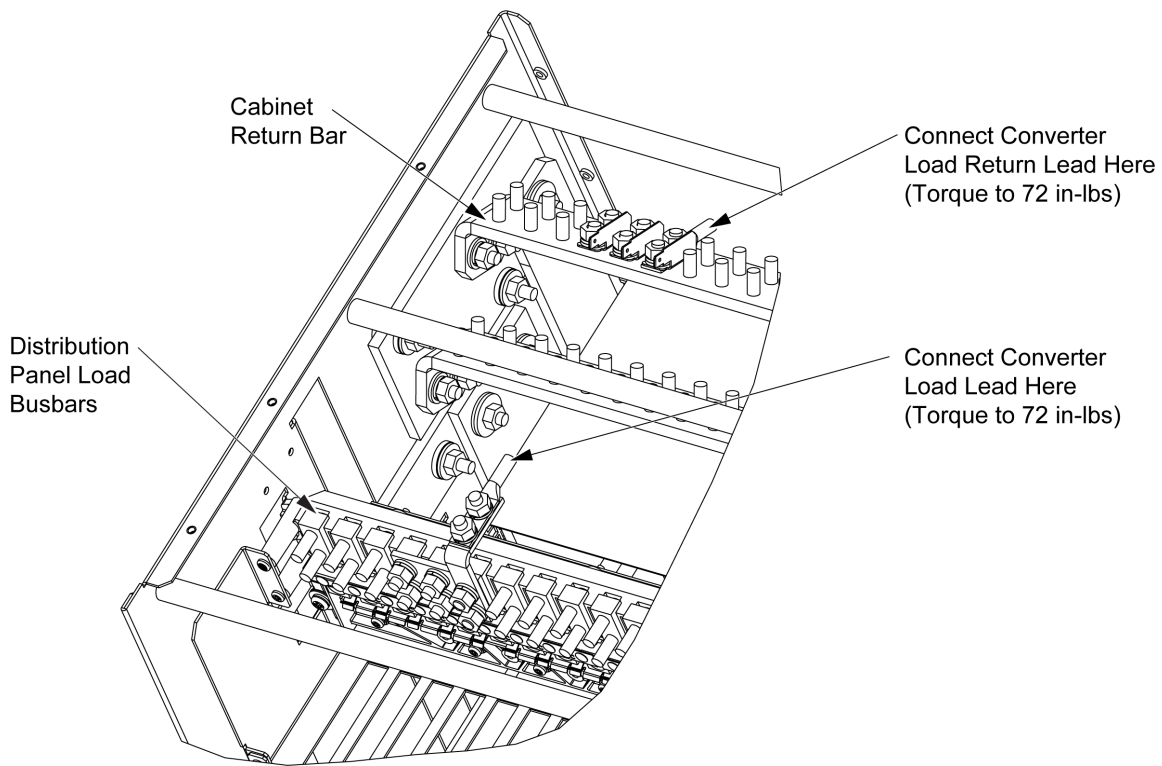
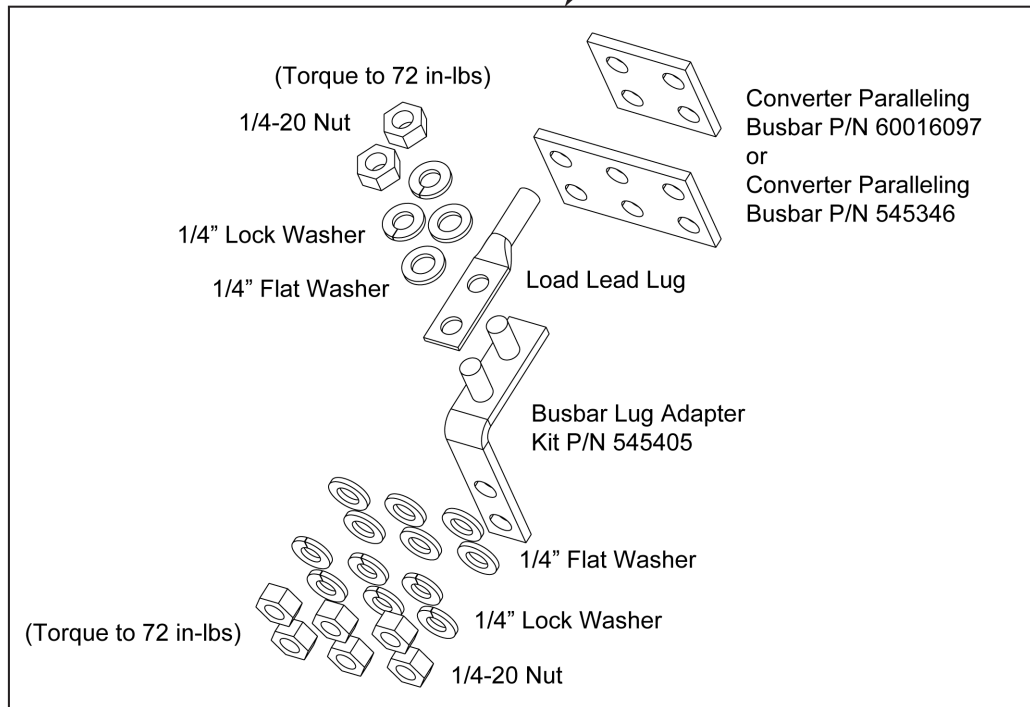
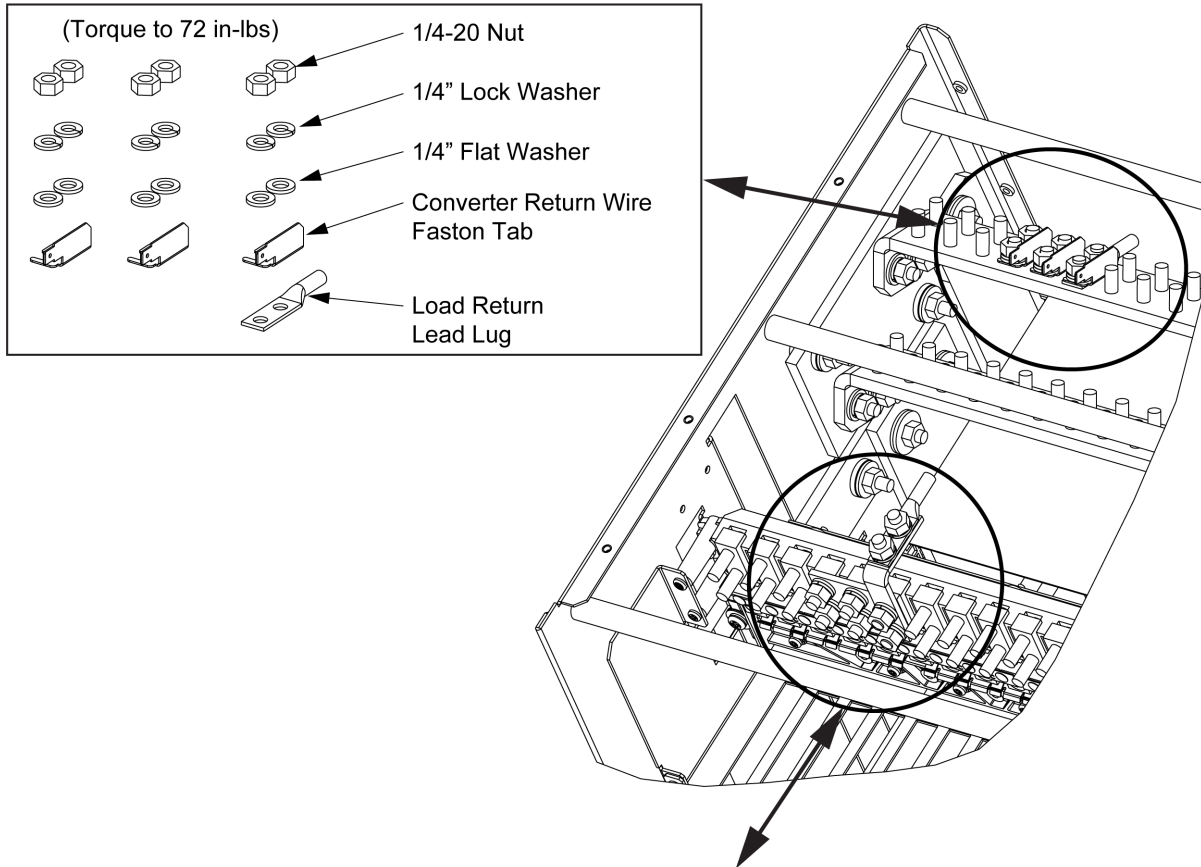

Figure 2.7 Connecting Converter Load and Load Return Cables, Installing Converter Return Wire Faston Tab, Installing Paralleling Busbar (P/N 60016097 or 545346) (cont'd from previous page)



- [] 4. Connect the return wire (P/N 564330) and 4-inch long return wire jumper (P/N 565752) provided with **each** converter to a converter return wire faston tab installed on the cabinet's return bar in the step above. Do this for all converters. See Figure 2.8.



NOTE! The converter is also furnished with an 8-inch long return wire jumper P/N 566207. The 8-inch long return wire jumper is not used with this mounting bracket kit. It is used in other kits.

- [] 5. Route the return wires (P/N 564330) as shown in Figure 2.8, then connect them to the converters. Orient the white square on the return wire faston receptacle's locking tab as shown in Figure 2.8.

Figure 2.8 Connecting Converter Return Wire (P/N 564330) and Return Wire Jumper (P/N 565752)

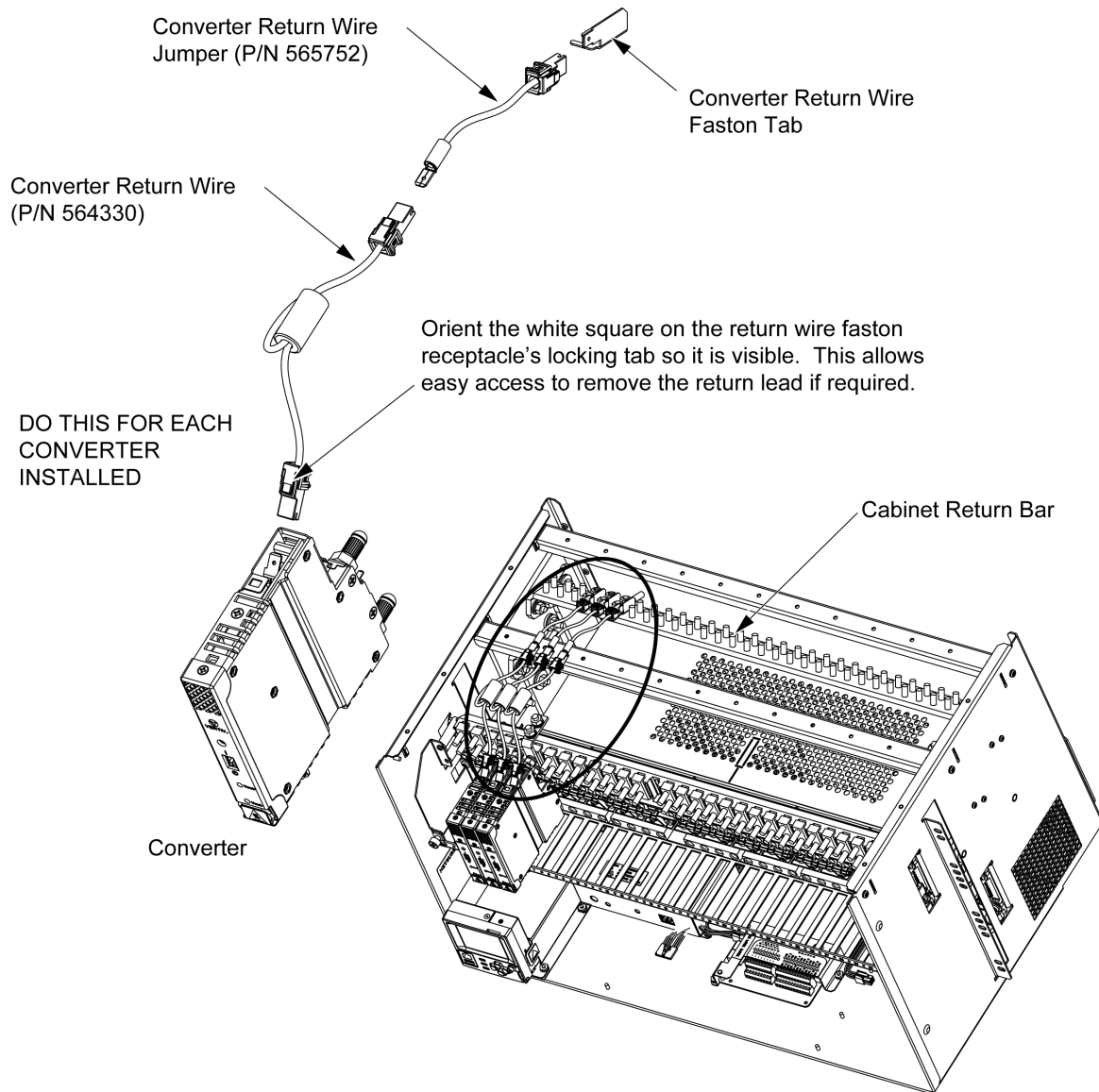

- [] 6. Ensure the enable/disable switch on all converters is in the disable (down) position. See Figure 2.9.

Figure 2.9 Enable/Disable Switch

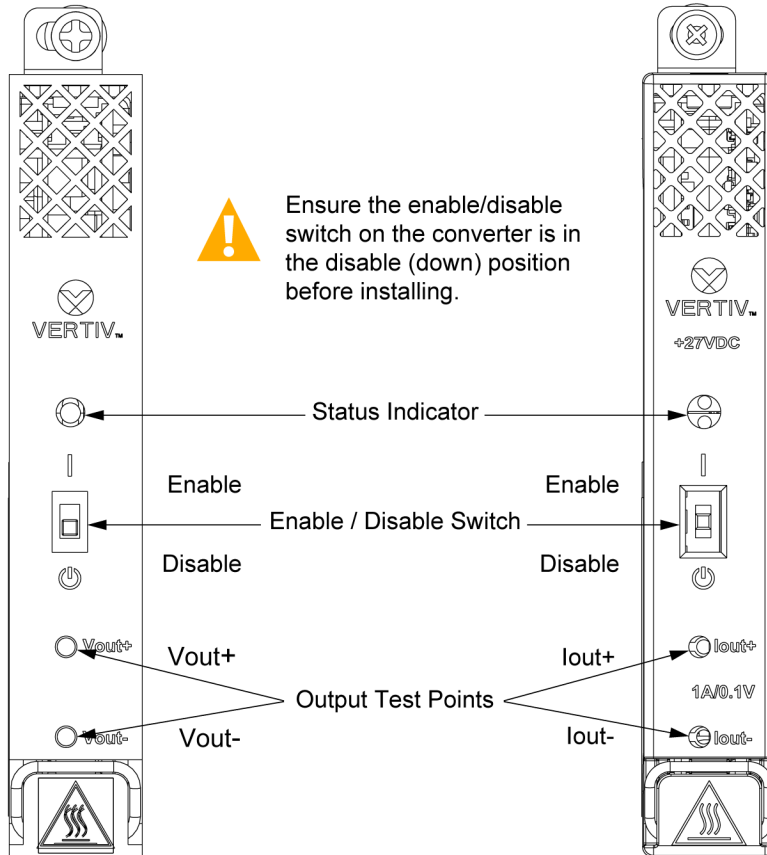

Note: Output Voltage measurement on the +27 VDC Vertiv™ eSure™ Bullet Converter represents output current. 1A/0.1V

- [] 7. Plug the converters into the distribution panel. See Figure 2.10.
- [] 8. Secure the converters to the front mounting bracket with the screws provided with the converters. Torque hardware as indicated in Figure 2.10.
- [] 9. Place the enable/disable switch on the converter to the enable position. See Figure 2.9. If two or three converters are connected in parallel to a load that exceeds the peak load rating for a single converter, they should be switched on simultaneously.
- [] 10. Observe the status of the converter front panel local indicator. If operating normally, this indicator should be illuminated green. See Figure 2.9.
- [] 11. Enable the external alarms or notify appropriate personnel that this procedure is finished.
- [] 12. Ensure that there are no local or remote alarms active on the power system.

Figure 2.10 Installing Converters

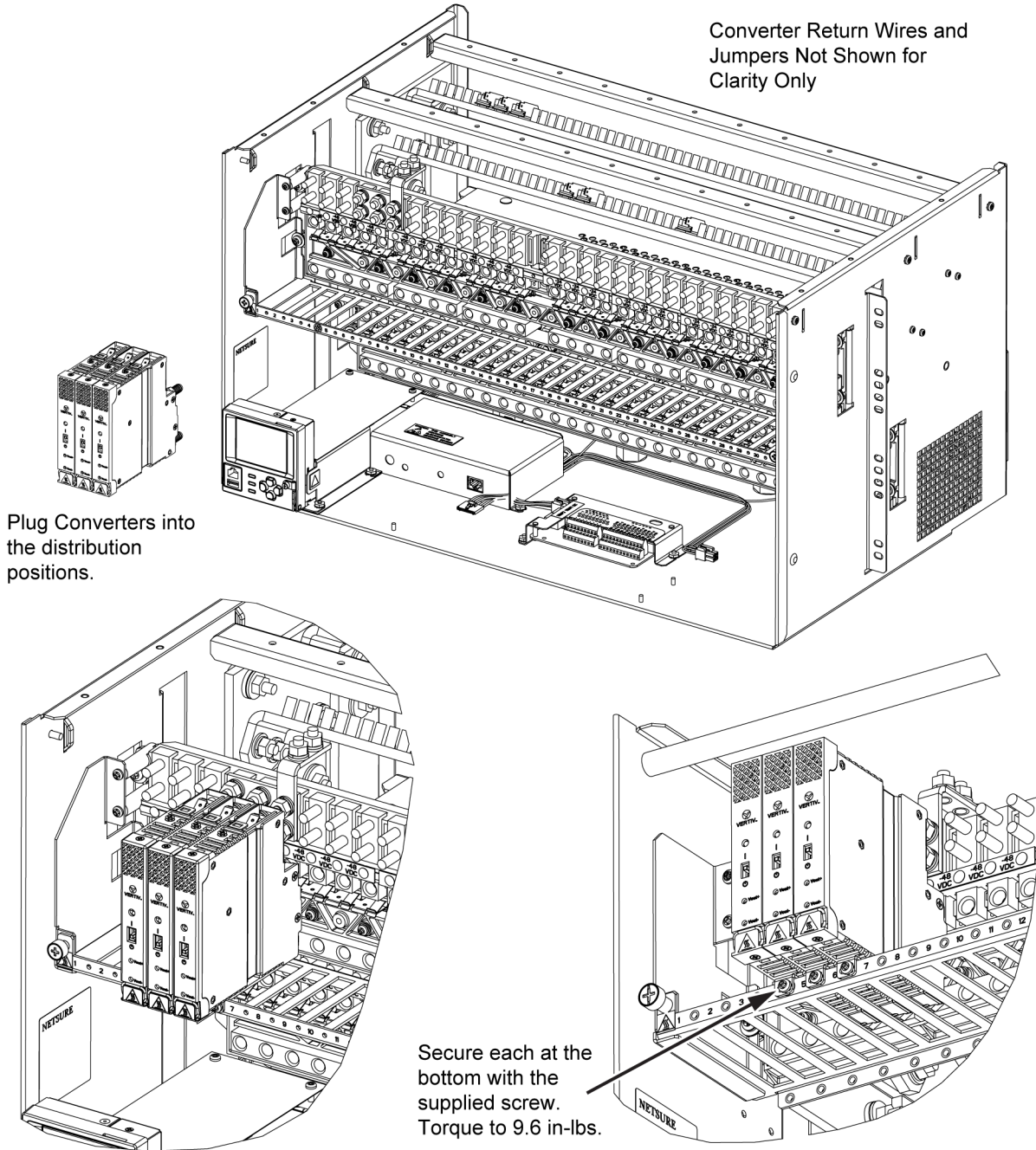

2.5 Single Converter Installation – Bottom Row

To parallel converters in the bottom row, refer to the procedure “Parallel Converter Installation – Bottom Row” starting on page 25.

Procedure

- [] 1. If the converter is to be installed for a newly connected load, connect the load and load return cables to the distribution position to be occupied by the converter. The connection for the load cable can be one of the busbar lug landing points directly behind the converter or to the positive side of the terminal block on the +27 VDC Bullet Nose 6-Position GMT Fuse Board (only used with the +27 VDC Vertiv™ eSure™ Bullet Converter). The connection for the return lead can be on the Return bar of the plant or the negative side of the terminal block on the +27 VDC Bullet Nose 6-Position GMT Fuse board. At the same time, connect the converter return wire faston tab provided with the converter to the cabinet’s return busbar (if present, use the same location as the return lead to the load). At the same time (if required), connect the separately ordered converter paralleling busbar to the distribution panel load busbars using the same location as the load lead to the load. If two or three converters are to be connected in parallel or if a +27 VDC Bullet Nose 6-Position GMT Fuse Board Kit (10062803) is used along with the converters, a two-position (60016097), three-position (545346), four-position (10078650), or five-position (10078651) lug adapter busbar plate should be installed first, as shown in the installation instructions in UM10062803. See Figure 2.11 and Figure 2.19. Torque hardware as indicated in Figure 2.11.
- [] 2. If the converter is to replace an existing circuit breaker, remove the circuit breaker and verify the load and return cables for the position are wired and labeled correctly. At the same time, connect the converter return wire faston tab provided with the converter to the cabinet’s return busbar (use the same location as the return lead to the load). At the same time (if required), connect the separately ordered converter paralleling busbar to the distribution panel load busbars (using the same location as the load lead to the load). If two or three converters are to be connected in parallel, a two-position (60016097), or three-position (545346), or four-position (10078650), or five-position (10078651) lug adapter busbar plate should be installed first. See Figure 2.11 and Figure 2.19. Torque hardware as indicated in Figure 2.11.
- [] 3. Connect the return wire (P/N 564330) and 4-inch long return wire jumper (P/N 565752) provided with the converter to the converter return wire faston tab installed on the cabinet’s return busbar in the step above. See Figure 2.12.



NOTE! The converter is also furnished with an 8-inch long return wire jumper P/N 566207. The 8-inch long return wire jumper is not used with this mounting bracket kit. It is used in other kits.

- [] 4. Route the return wire (P/N 564330) down and behind the top distribution row, then connect it to the converter. See Figure 2.12. Orient the white square on the return wire faston receptacle’s locking tab as shown in Figure 2.12.



NOTE! The following images show two- and three-position lug adapter busbar plates. Four- and five-position adapter plates are also available and are installed similarly.

Figure 2.11 Connecting Converter Load and Load Return Cables, Installing Converter Return Wire Faston Tab

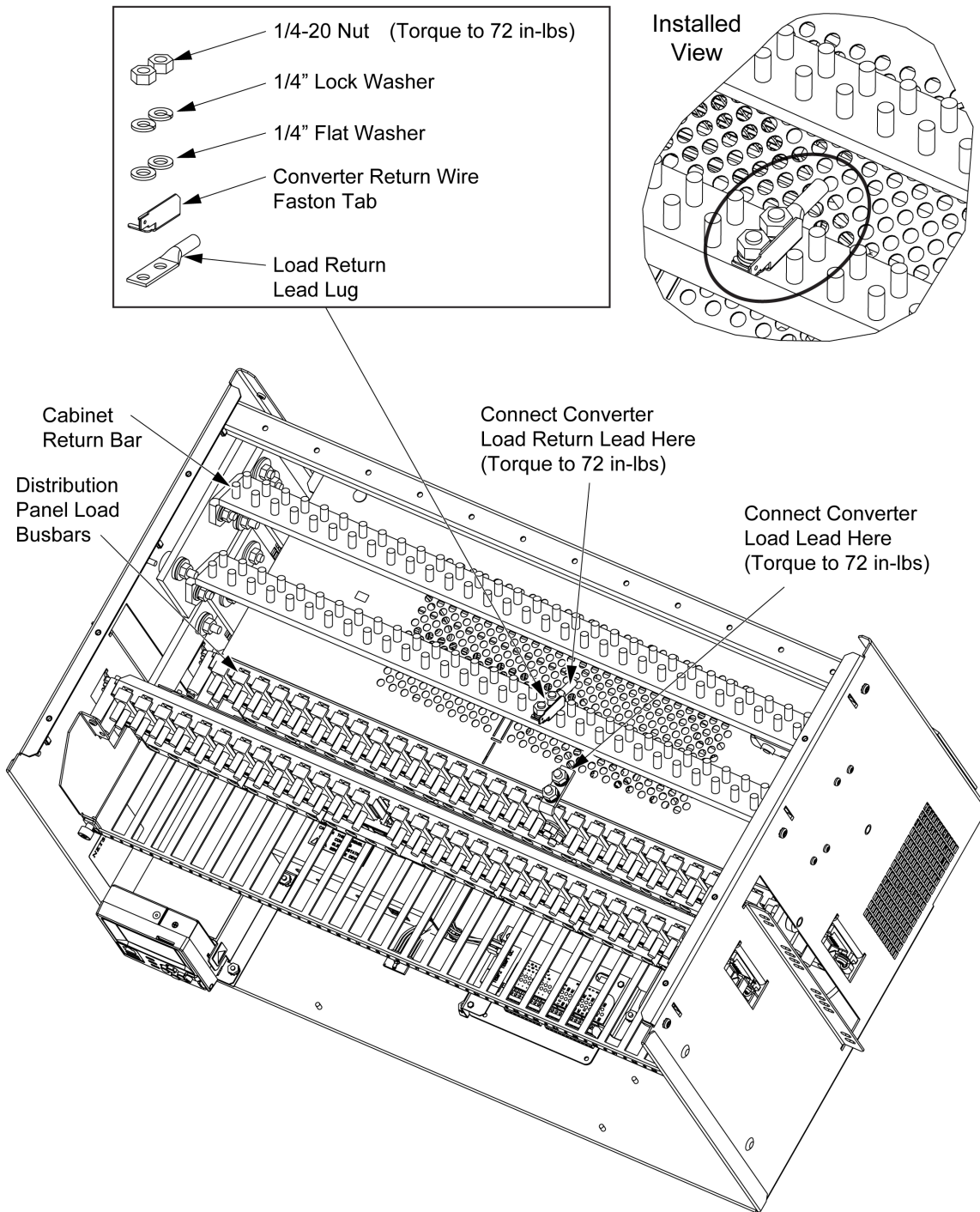
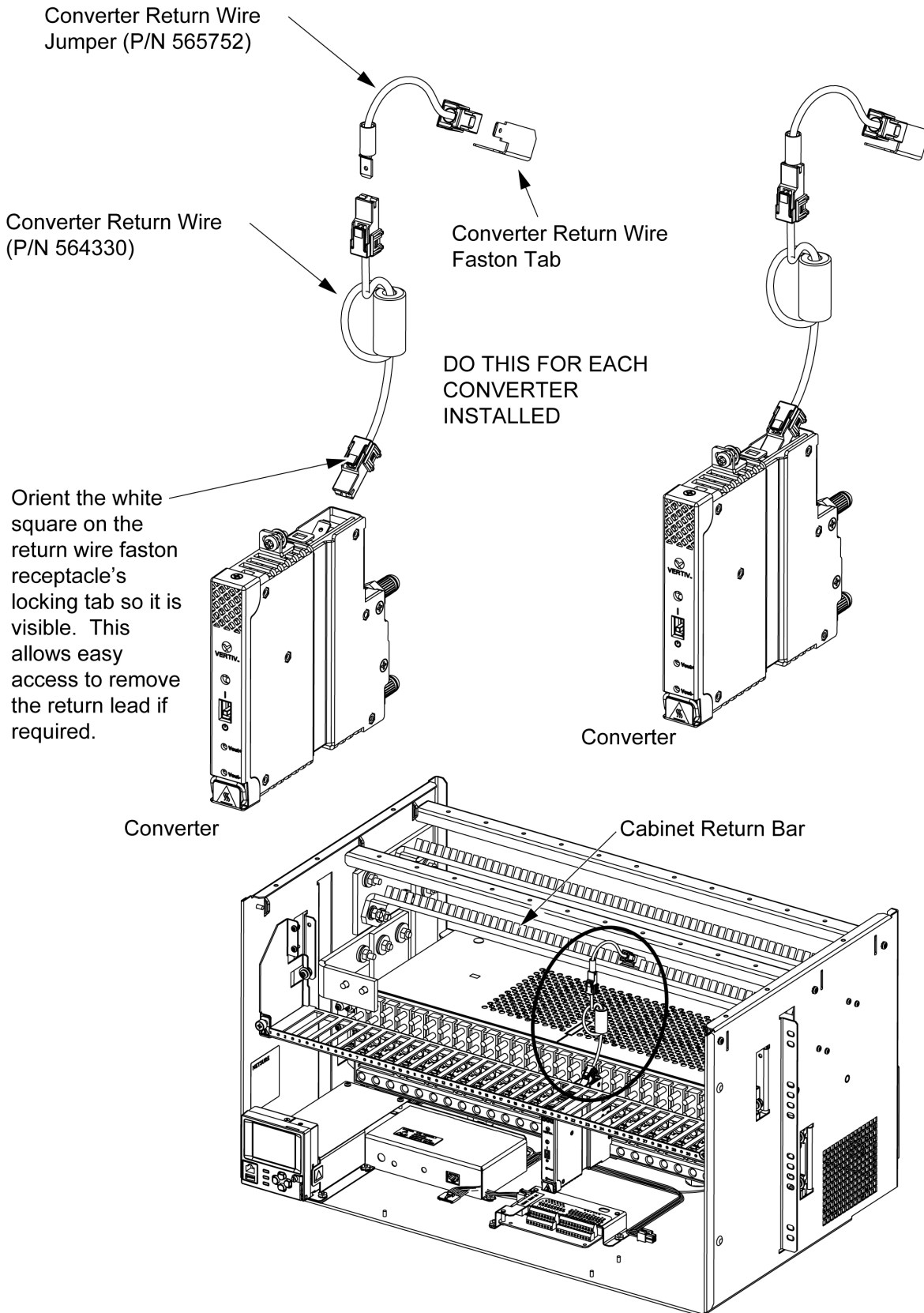
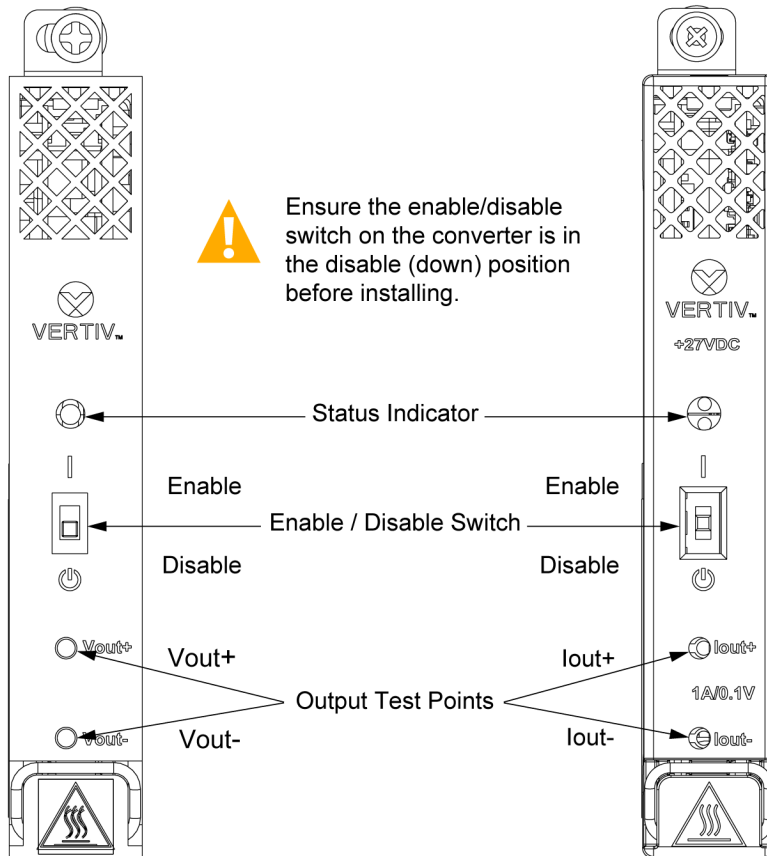

Figure 2.12 Connecting Converter Return Wire (P/N 564330) and Return Wire Jumper (P/N 565752)



- [] 5. Ensure the enable/disable switch on the converter is in the disable (down) position. See Figure 2.13.

Figure 2.13 Enable/Disable Switch



Note: Output Voltage measurement on the +27 VDC Vertiv™ eSure™ Bullet Converter represents output current. 1A/0.1V

- [] 6. Plug the converter into the distribution panel. See Figure 2.14.
- [] 7. Secure the converter to the front mounting bracket with the screw provided with the converter. Torque hardware as indicated in Figure 2.14.
- [] 8. Place the enable/disable switch on the converter to the enable position. See Figure 2.13.
- [] 9. Observe the status of the converter front panel local indicator. If operating normally, this indicator should be illuminated green. See Figure 2.13.
- [] 10. Enable the external alarms or notify appropriate personnel that this procedure is finished.
- [] 11. Ensure that there are no local or remote alarms active on the power system.

Figure 2.14 Installing Converter

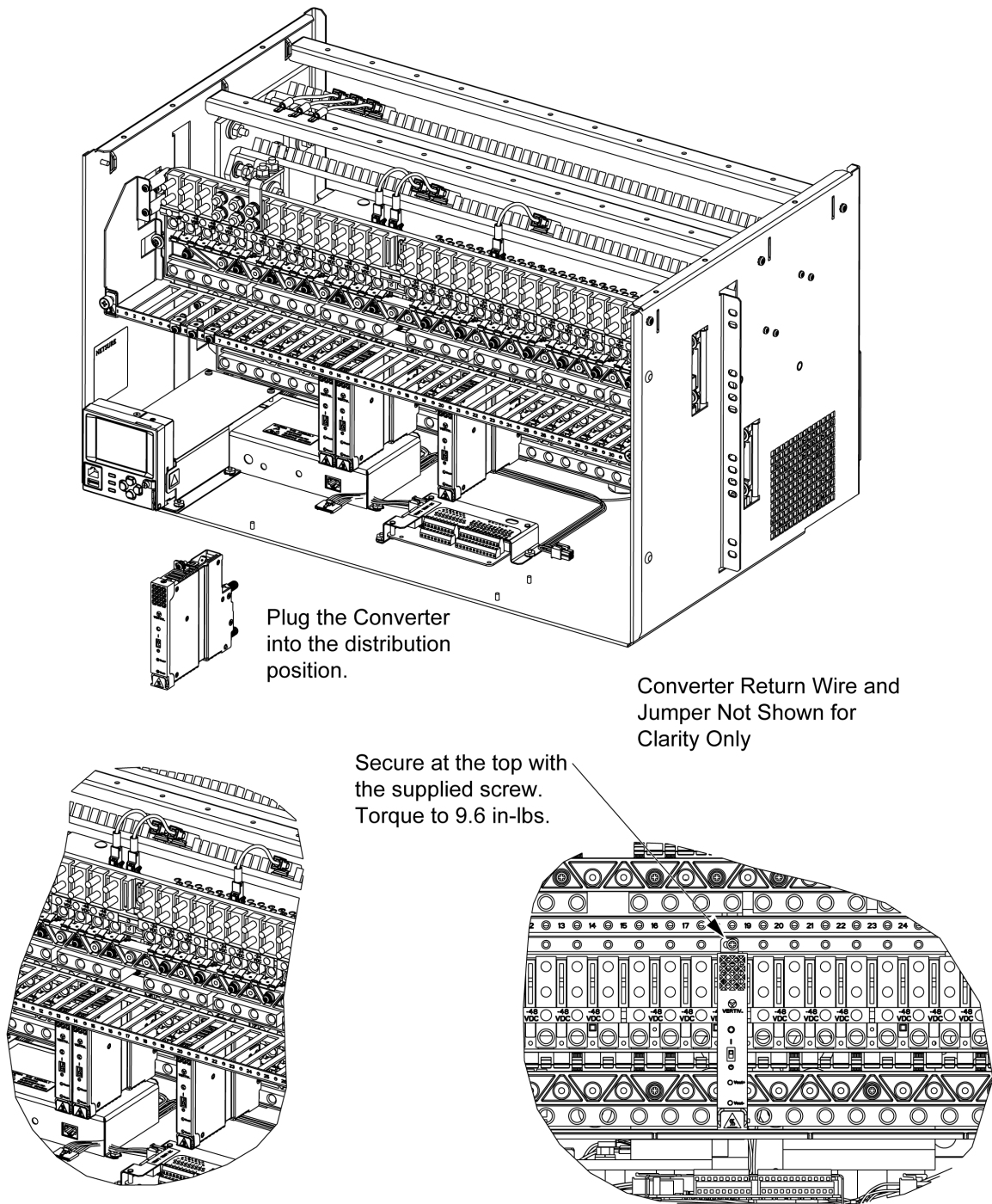

2.6 Parallel Converter Installation – Bottom Row

To install a single converter in the bottom row, refer to the procedure “Single Converter Installation – Bottom Row” starting on page 20.

Procedure

- [] 1. If the converter is to be installed for a newly connected load, connect the load and load return cables to the distribution position to be occupied by the converter. The connection for the load cable can be one of the busbar lug landing points directly behind the converter or to the positive side of the terminal block on the +27 VDC Bullet Nose 6-Position GMT Fuse Board (only used with the +27 VDC Vertiv™ eSure™ Bullet Converter). The connection for the return lead can be on the Return bar of the plant or the negative side of the terminal block on the +27 VDC Bullet Nose 6-Position GMT Fuse board. At the same time, connect the converter return wire faston tab provided with the converter to the cabinet's return busbar (if present, use the same location as the return lead to the load). At the same time (if required), connect the separately ordered converter paralleling busbar to the distribution panel load busbars using the same location as the load lead to the load. If two or three converters are to be connected in parallel or if a +27 VDC Bullet Nose 6-Position GMT Fuse Board Kit (10062803) is used along with the converters, a two-position (60016097), three-position (545346), four-position (10078650), or five-position (10078651) lug adapter busbar plate should be installed first, as shown in the installation instructions in UM10062803. See Figure 2.15 and Figure 2.19. Torque hardware as indicated in Figure 2.15.
- [] 2. If the converter is to replace an existing circuit breaker, remove the circuit breaker and verify the load and return cables for the position are wired and labeled correctly. At the same time, connect the converter return wire faston tab provided with the converter to the cabinet's return busbar (use the same location as the return lead to the load). At the same time (if required), connect the separately ordered converter paralleling busbar to the distribution panel load busbars (using the same location as the load lead to the load). If two or three converters are to be connected in parallel, a two-position (60016097), or three-position (545346), or four-position (10078650), or five-position (10078651) lug adapter busbar plate should be installed first. See Figure 2.15 and Figure 2.19. Torque hardware as indicated in Figure 2.15.
- [] 3. Connect the return wire (P/N 564330) and 4-inch long return wire jumper (P/N 565752) provided with **each** converter to the converter return wire faston tab installed on the cabinet's return busbar in the step above. Do this for all converters. See Figure 2.16.



NOTE! The converter is also furnished with an 8-inch long return wire jumper P/N 566207. The 8-inch long return wire jumper is not used with this mounting bracket kit. It is used in other kits.

- [] 4. Route the return wires (P/N 564330) down and behind the top distribution row, then connect them to the converters. See Figure 2.16. Orient the white square on the return wire faston receptacle's locking tab as shown in Figure 2.16.



NOTE! The following images show two- and three-position lug adapter busbar plates. Four- and five-position adapter plates are also available and are installed similarly.

Figure 2.15 Connecting Converter Load and Load Return Cables, Installing Converter Return Wire Faston Tab, Installing Paralleling Busbar (P/N 60016097 or 545346) (cont'd on next page)

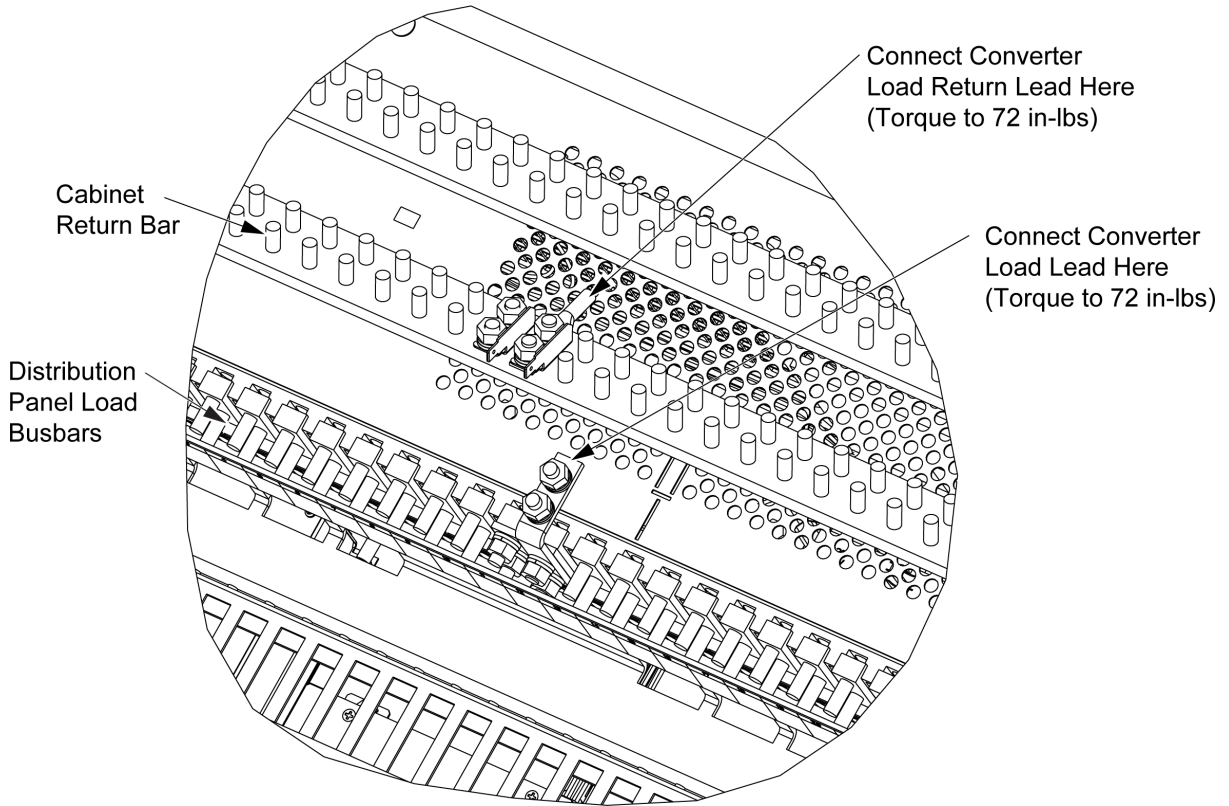
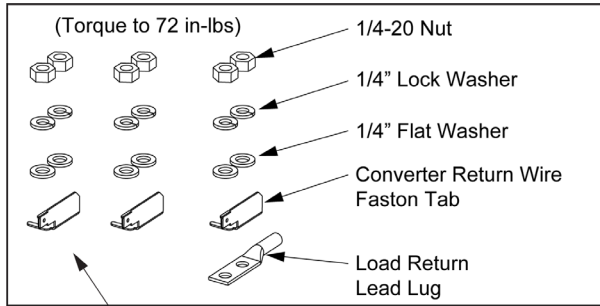

Figure 2.15 Connecting Converter Load and Load Return Cables, Installing Converter Return Wire Faston Tab, Installing Paralleling Busbar (P/N 60016097 or 545346) (cont'd from previous page)



Install only if (3) converters are paralleled.

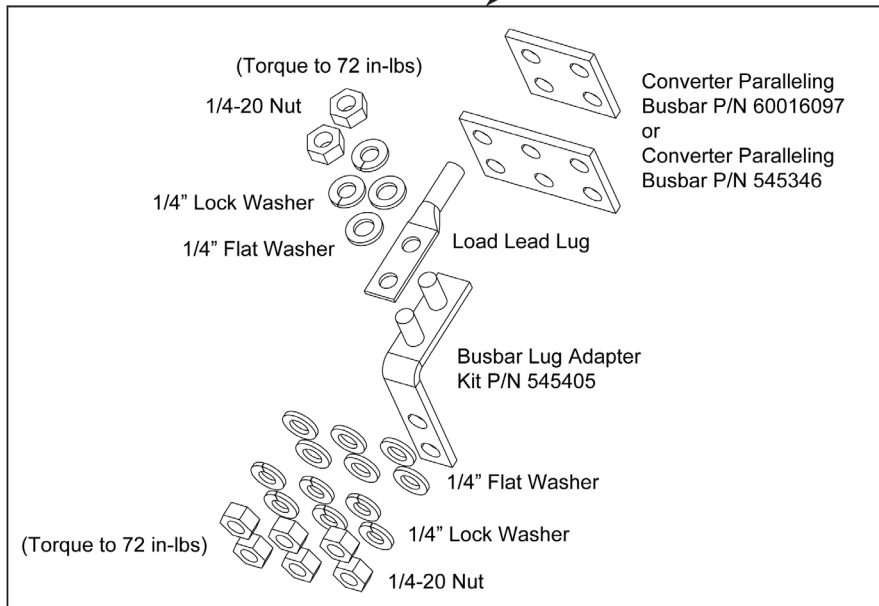
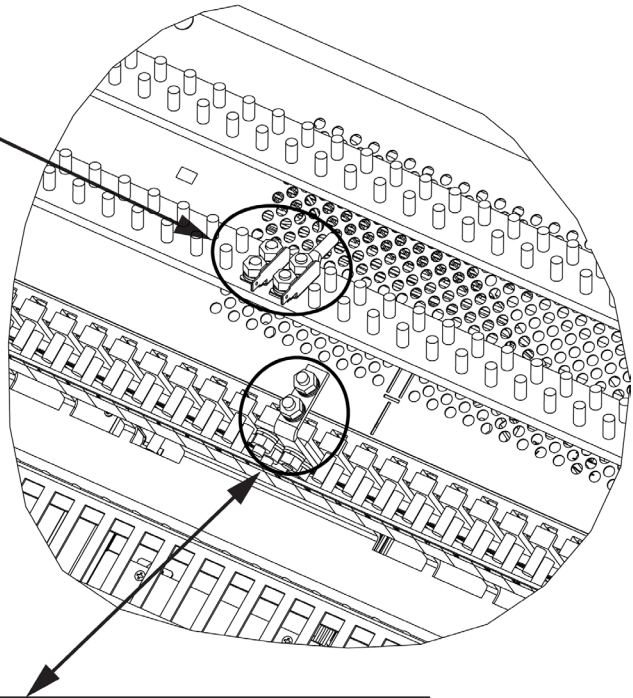
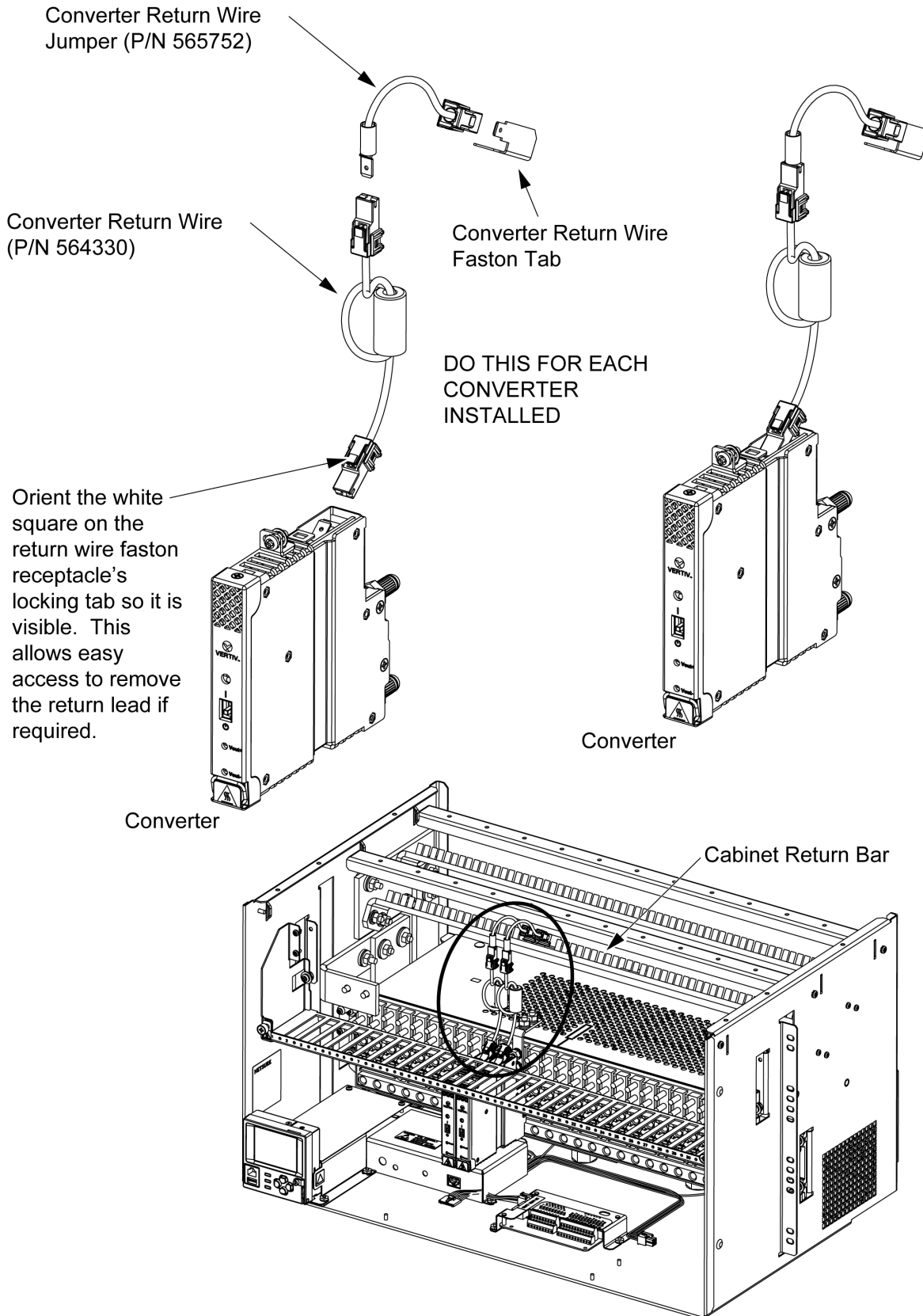
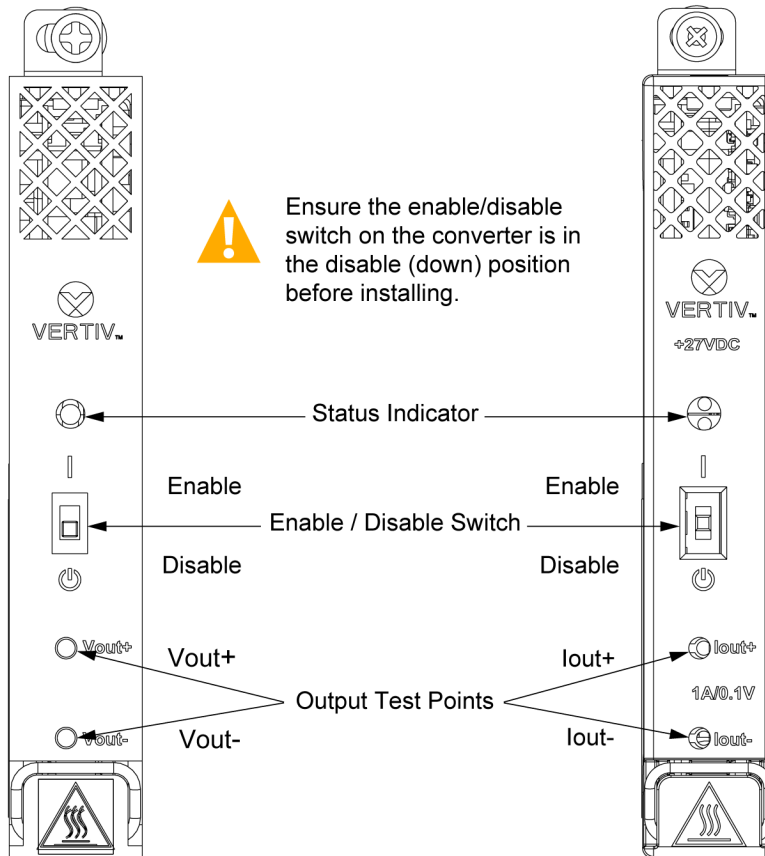

Figure 2.16 Connecting Converter Return Wire (P/N 564330) and Return Wire Jumper (P/N 565752)



- [] 5. Ensure the enable/disable switch on the converter is in the disable (down) position. See Figure 2.17.

Figure 2.17 Enable/Disable Switch



Note: Output Voltage measurement on the +27 VDC Vertiv™ eSure™ Bullet Converter represents output current. 1A/0.1V

- [] 6. Plug the converters into the distribution panel. See Figure 2.18.
- [] 7. Secure the converters to the front mounting bracket with the screws provided with the converters. Torque hardware as indicated in Figure 2.18.
- [] 8. Place the enable/disable switch on the converter to the enable position. See Figure 2.17. If two or three converters are connected in parallel to a load that exceeds the peak load rating for a single converter, they should be switched on simultaneously.
- [] 9. Observe the status of the converter front panel local indicator. If operating normally, this indicator should be illuminated green. See Figure 2.17.
- [] 10. Enable the external alarms or notify appropriate personnel that this procedure is finished.
- [] 11. Ensure that there are no local or remote alarms active on the power system.

Figure 2.18 Installing Converters

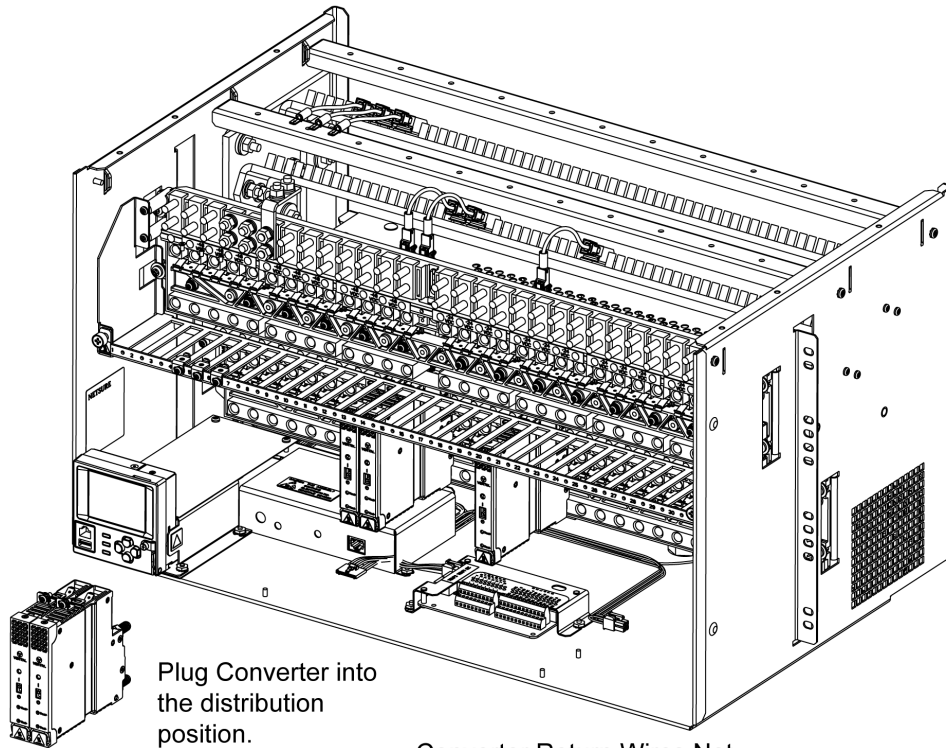

Plug Converter into the distribution position.

Converter Return Wires Not Shown Connected for Clarity Only

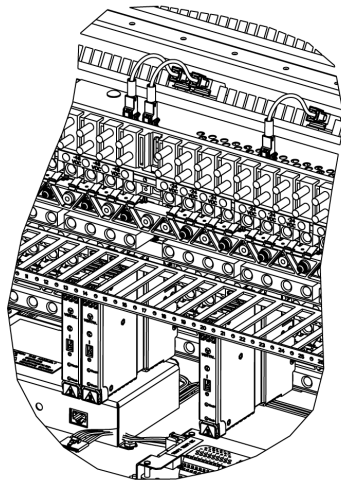

Secure at the top with the supplied screw. Torque to 9.6 in-lbs.

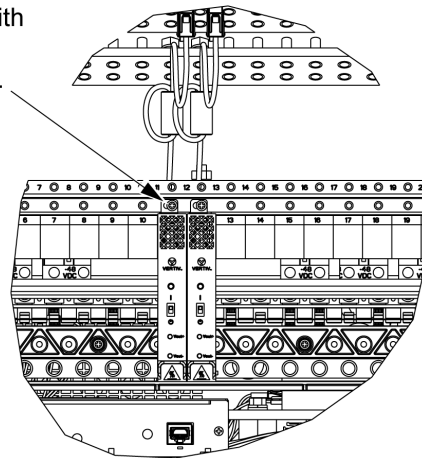
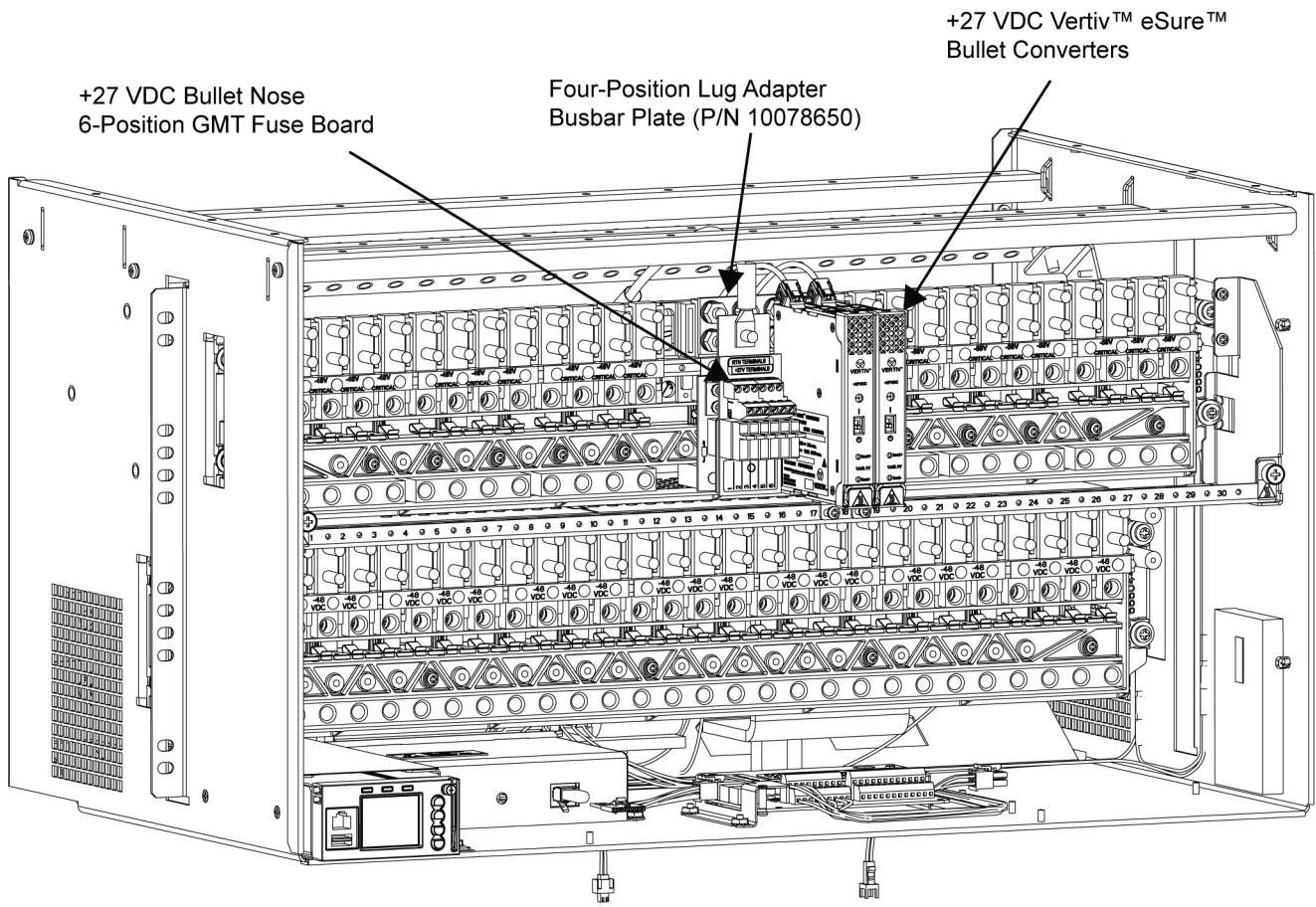

Figure 2.19 Installed +27 VDC Vertiv™ eSure™ Bullet Converters and +27 VDC Bullet Nose 6-Position GMT Fuse Board



This page intentionally left blank.

Connect with Vertiv on Social Media



<https://www.facebook.com/vertiv/>



<https://www.instagram.com/vertiv/>



<https://www.linkedin.com/company/vertiv/>



<https://www.twitter.com/vertiv/>



Vertiv.com | Vertiv Headquarters, 505 N Cleveland Ave, Westerville, OH 43082, USA

© 2024 Vertiv Group Corp. All rights reserved. Vertiv™ and the Vertiv logo are trademarks or registered trademarks of Vertiv Group Corp. All other names and logos referred to are trade names, trademarks or registered trademarks of their respective owners. While every precaution has been taken to ensure accuracy and completeness here, Vertiv Group Corp. assumes no responsibility, and disclaims all liability, for damages resulting from use of this information or for any errors or omissions.