



Vertiv™ CoolChip EconoPhase CDU



Vertiv™ CoolChip EconoPhase CDU

Vertiv™ CoolChip EconoPhase CDU is a refrigerant-to-liquid distribution unit designed for the streamlined deployment of high-density applications in air-cooled data centers. For direct-to-chip (DTC) or rear door heat exchanger (RDHx) loads, the system can be paired with existing air-cooled infrastructure, to deliver increased reliability, availability, and efficiency.

Data centers with air-cooled architecture have long enjoyed the efficiency, scalability, and flexibility inherent in their cooling strategies. However, deploying newer high-density equipment in these environments presents a formidable challenge: How do you effectively cool the equipment without retrofitting an entire air-cooled environment?

The Vertiv CoolChip EconoPhase CDU resolves the issue, making it simple to integrate high-density cooling where needed, without the need to reengineer the entire data center environment. Using Pumped Refrigerant Economization (PRE) in the primary loop to the condenser, Vertiv CoolChip EconoPhase CDU removes heat from the secondary fluid network in a refrigerant-to-liquid heat exchanger. This secondary fluid network can deliver high-density cooling to direct-to-chip cold plates and act as coolant distribution unit (CDU) or to RDHx's, such as Vertiv™ Liebert® DCD. The chiller provides the variable speed pumps and heat rejection solution you need to efficiently handle the high heat output from racks located in your data center.



Key Benefits

- Easily and cost-effectively incorporate liquid-cooling in your existing air-cooled environment
- Improve efficiency with variable speed pumps, integrated filtration, and on-board monitoring and controls
- Support both Direct-to-Chip and RDHx applications
- Add flexibility and redundancy with modular units that can function independently or in teamwork mode
- Leverage existing deployed DX condensers, reducing the cost and startup time for liquid cooling deployments
- Mix and match air cooled and liquid cooled units to simplify retrofits and future-proof your data center design
- Lower your total cost of ownership with easy-to-deploy, efficient, and highly flexible high-density cooling solution

Modular Building Blocks

The Vertiv™ CoolChip EconoPhase CDU is engineered with a similar footprint to the air-cooled Vertiv™ Liebert® DSE, the world's leading PRE solution for data centers. The equal building blocks allow you to easily address small pods of high-density equipment in existing data centers. Front and top service access eliminates the need to leave room for service clearance and allow units to be placed side by side, optimizing available floor space and further simplifying retrofits and planning.

Unit-to-Unit Teamwork

Each cooling module operates independently to ensure complete redundancy for your cooling applications. They can also function in teamwork mode to adapt to changes in the facility and IT demand, improving energy efficiency and IT equipment availability while reducing system wear and tear, maximizing the useful life of the equipment, and further reducing the total cost of ownership.

Vertiv™ CoolChip EconoPhase CDU Features

Leverage Existing Infrastructure

such as previously deployed Vertiv™ Liebert® MCV rooftop condensing units to provide direct-to-chip liquid cooling in traditionally air-cooled environments.

Pumped Refrigerant Economization

(PRE) efficiently and reliably cools pods of high-density racks without the need for chilled water.

Variable Speed Pumps

allow for variation in flow of PRE based on load demand, increasing efficiency and saving energy dollars.

Modular Design supports efficiency and redundancy needs by allowing units to function independently or in teamwork mode, so you can add the cooling capacity and protection when you need it.

Standard Footprint that mirrors the size of air-cooled Vertiv™ Liebert® DSE units, simplifying retrofits, future proofing new data center designs, and allowing you to mix and match units to customize your cooling strategy.

Dual Power with Reversing Starter

allows you to apply a backup generator in addition to the main power source and enables automatic switchover between the two, ensuring uninterrupted operation.

Supercap for quick start and fast restart after power loss.

Front and Top Service Access

increases installation flexibility.

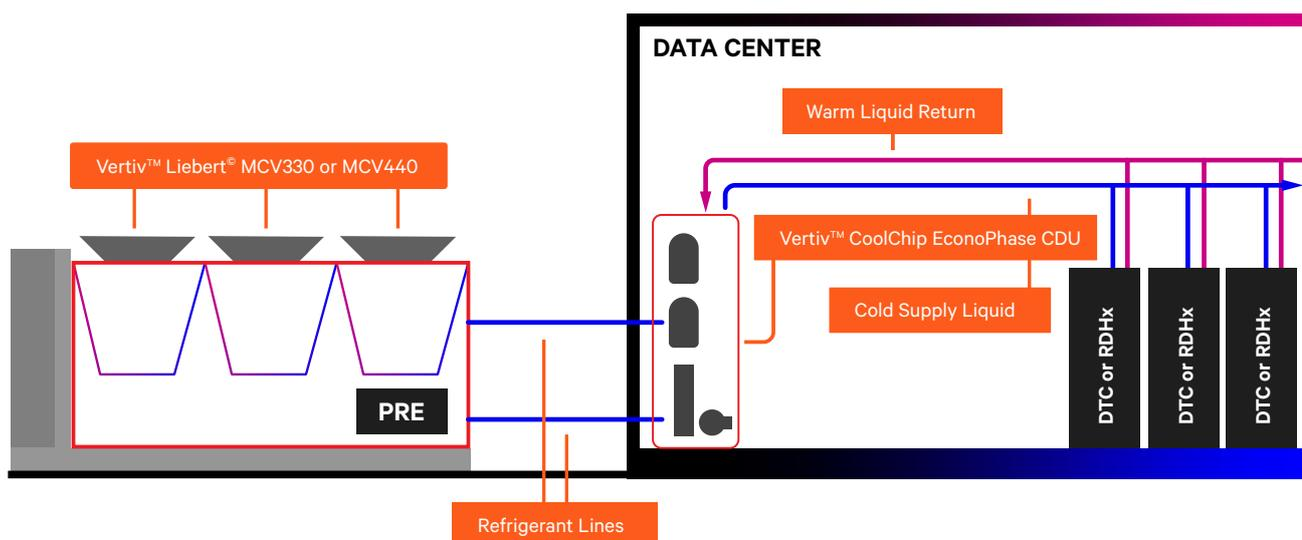

Working in tandem with direct-to-chip cold plates or rear door heat exchangers, the Vertiv™ CoolChip EconoPhase CDU utilizes pumped refrigerant economization (PRE) to eliminate the need for chilled water, allowing you to easily and efficiently cool pods of high-density racks in your air-cooled data center.

How You Benefit from the CoolChip EconoPhase CDU

The Complete System – All in One



- Chiller – Functions like a chiller without the need to redesign the data center to deploy chilled water
- CDU – Provides direct-to-chip cooling for liquid cooled servers requiring higher filtration and flow rates
- Heat Rejection – Compatible with Vertiv™ Liebert® MCV units for increased efficiency gains and high-capacity heat rejection
- Fluid Pump – Integrated variable speed pumps provide outstanding availability for direct-to-chip and RDHX applications
- Communication and Controls – Integrated remote monitoring and management allow for optimized operations and increased efficiency

Rapid High-Density Deployments



- Speed deployments and reduce CapEx by utilizing existing air-cooling infrastructure
- Refrigerant-to-liquid design eliminates the need to bring chilled water systems on site
- Functions as chiller, pump, CDU, heat rejection, and control system, reducing the time to deploy a full solution with multiple components
- Modular design allows for additional deployments of high density

Improved PUE and TCO



- Pumped refrigerant economization technology provides highly efficient free cooling operation with DX heat rejection when needed
- PRE operation automatically adjusts based on ambient operating conditions, providing hands-off and worry-free savings

Technical Specifications

Model	300 kW
W x D x H mm(inch)	2083 x 587 x 3275 (82 x 23.1 x 129)
Weight Dry +/- 5% kg (lbs.)	3205 (1454)
Shipping Dimensions	3251 x 1676 x 2567 (128 x 66 x 97) (Two sections on same pallet)
Packaging Weight +/- 5% kg (lbs.)	219 (484)

Customer Connections

Primary Loop (Refrigerant)	1-3/8" O.D. Cu
Secondary Loop (Chilled Water)	3" Stainless Steel
Primary Loop Fluid (refrigerant)	R410A
Secondary Loop Fluid	Water / Water-glycol
Secondary Loop Filtration	50µm
Secondary Loop Valves Max Water Pressure	400PSI (2758kPA)
Pump Redundancy	Single pump (N)

Electrical Specifications

Model	300 kW			
Technical Specifications	460V / 60Hz / 3Ph			
SCCR (Short Circuit Current Rating)	65 kA			
Dual Power Feeds (ATS)	Dual Disconnect (7.5HP, MCV440, PRE)	Single Disconnect (15HP, MCV440, PRE)	Dual Disconnect (15HP, MCV440, PRE)	Dual Disconnect w UPS (15HP, MCV440, PRE)
FLA (Full Load Amps)	114.2	141.6	164	130 (34 UPS)
WSA (Wire Size Amps)	119.4	148.3	170.7	136.7 (38.3 UPS)
OPD (Overcurrent Protection Device Amps)	125	175	175	150 (50 UPS)

Remote Monitoring and Control

Model	300 kW
Vertiv™ Liebert® iCOM™	SNMPv1/v2c/v3, HTTP, SMTP, SMS

Compatibility Data

Model	300 kW
Outdoor Heat Rejection	Vertiv™ Liebert® MCV430 / 440
Vertiv™ Liebert® DSE Unit Retrofit	Vertiv™ Liebert® DSE 265
Liquid Cooling Module	Direct to Chip (DTC) or RDHx (Liebert® DCD 35/47/50)

Pumped Refrigerant Economization

1. Full Compressor Mode

During warm summer months, the refrigerant pump is idled, and the system instead uses compressors to drive heat rejection. To maximize efficiency in this scenario, the variable-speed evaporator fans, variable speed condenser fans, and the digital scroll compressors automatically adjust to match IT load and optimize energy usage.

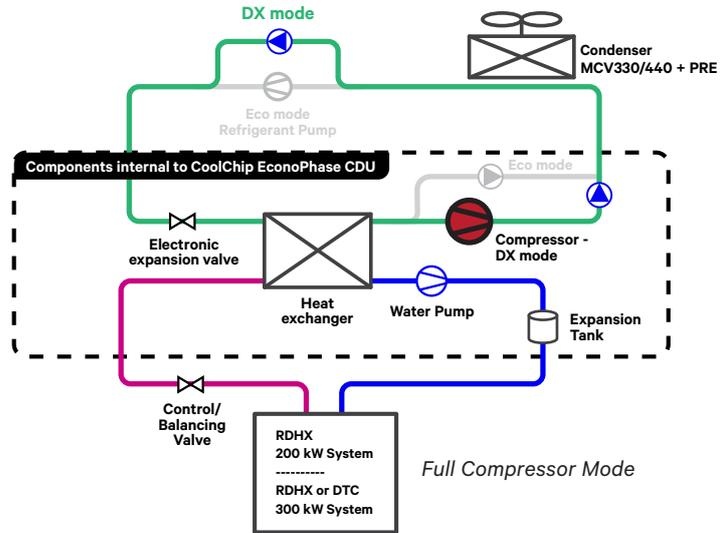

2. Partial Economization

During cooler times, such as mild seasons and at night, the refrigerant economizer can provide partial free cooling, offsetting some of the compressor power usage. In this mode, refrigerant bypasses the unit's first compressor, allowing it to idle. Pump One of the system is then activated, consuming only 0.6 kW - a net savings of over 90% compared to compressor operation. The result is a lower cooling PUE for the system.

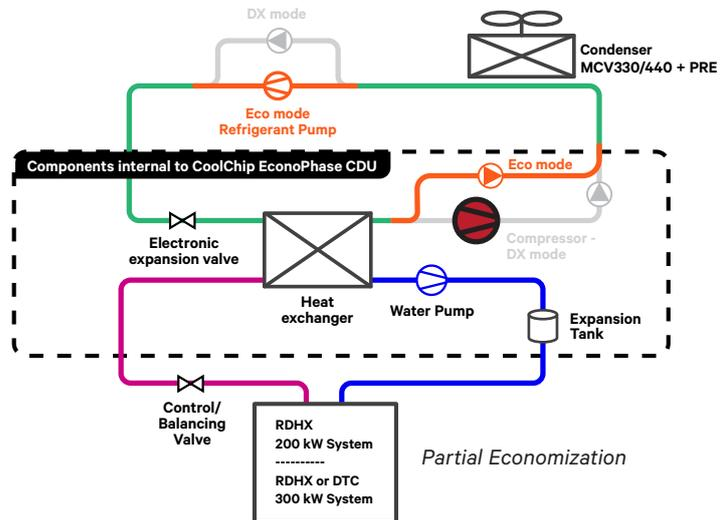

3. Full Economization

When outdoor temperatures are at their lowest (particularly in winter months), the Vertiv™ CoolChip EconoPhase CDU can leverage the Vertiv™ Liebert® EconoPhase system built into the Vertiv™ Liebert® MCV to operate at full economization. In this scenario, all of the system's compressors are idled and bypassed, replaced entirely by both refrigerant pumps in the Liebert® EconoPhase unit delivering maximized operational efficiency.

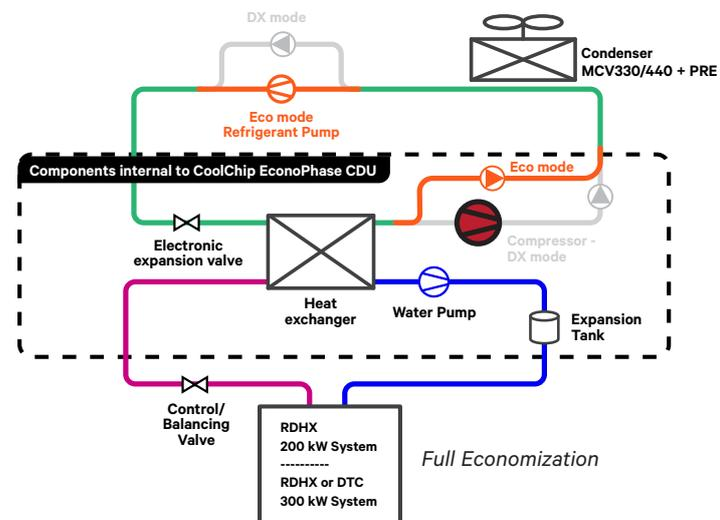



Vertiv.com | Vertiv Headquarters, 505 N Cleveland Ave, Westerville, OH 43082, USA

© 2024 Vertiv Group Corp. All rights reserved. Vertiv™ and the Vertiv logo are trademarks or registered trademarks of Vertiv Group Corp. All other names and logos referred to are trade names, trademarks or registered trademarks of their respective owners. While every precaution has been taken to ensure accuracy and completeness here, Vertiv Group Corp. assumes no responsibility, and disclaims all liability, for damages resulting from use of this information or for any errors or omissions. Specifications, rebates and other promotional offers are subject to change at Vertiv's sole discretion upon notice.

SL-71255 (05/24)