



Liebert[®] CWA

Installer/User Guide

Thermal Wall 50/60 Hz

The information contained in this document is subject to change without notice and may not be suitable for all applications. While every precaution has been taken to ensure the accuracy and completeness of this document, Vertiv assumes no responsibility and disclaims all liability for damages resulting from use of this information or for any errors or omissions.

Vertiv recommends installing a monitored fluid detection system that is wired to activate the automatic closure of field-installed coolant fluid supply and return shut off valves, where applicable, to reduce the amount of coolant fluid leakage and consequential equipment and building damage.

Refer to local regulations and building codes relating to the application, installation, and operation of this product. The consulting engineer, installer, and/or end user is responsible for compliance with all applicable laws and regulations relating to the application, installation, and operation of this product.

The products covered by this instruction manual are manufactured and/or sold by Vertiv. This document is the property of Vertiv and contains confidential and proprietary information owned by Vertiv. Any copying, use, or disclosure of it without the written permission of Vertiv is strictly prohibited.

Names of companies and products are trademarks or registered trademarks of the respective companies. Any questions regarding usage of trademark names should be directed to the original manufacturer.

Technical Support Site

If you encounter any installation or operational issues with your product, check the pertinent section of this manual to see if the issue can be resolved by following outlined procedures.

Visit <https://www.vertiv.com/en-us/support/> for additional assistance.

TABLE OF CONTENTS

1 Important Safety Instructions	1
2 Nomenclature and Components	7
2.1 Vertiv™ Liebert® CWA Model Number Nomenclature	7
2.2 Component Location	9
2.3 Vertiv™ Liebert® CWA Physical Data	10
3 Pre-Installation Preparation and Guidelines	11
3.1 Planning Dimensions	11
3.2 Connections and System Setup	12
3.3 Operating Conditions	12
3.3.1 Humidification Control	12
3.4 Shipping Dimensions and Unit Weights	12
3.5 Site Preparation	12
3.5.1 Preparing a Concrete Slab	13
4 Equipment Inspection and Handling and Installation	15
4.1 Packaging Material	15
4.2 Handling the Modules While Packaged	16
4.3 Unpacking the Modules	16
4.3.1 Filter and Rack Removal	16
4.4 Preparing for Assembly	17
4.4.1 Top Module Prep on Skid	17
4.4.2 Top Module—Venting the Inert Gas Holding Charge	18
4.4.3 Bottom Module Prep on Skid	19
4.4.4 Bottom Module—Venting the Inert Gas Holding Charge	20
4.4.5 Removing Lag Screw Shipping Fasteners	22
4.5 Assembly of Top and Bottom Modules	23
4.6 Final Installation	24
5 Electrical Connections	27
5.1 Low Voltage Liqui-Tech Sensor Location	29
5.2 Air Temperature Sensor Location (Data Hall Side Only)	31
6 Piping Requirements	33
6.1 Drain Fluid Connections	33
6.1.1 Field Installed, Gravity Drain Line Requirements	34
6.2 Chilled Water Loop Piping Guidelines	34
6.2.1 Flanged Connections	36
6.2.2 Leak Checking for Unit and Field Installed Piping	37
7 Checklist for Completed Installation	39
7.1 Moving and Placing Equipment	39

- 7.2 Electrical Installation Checks 39
- 7.3 Piping Installation Checks 39
- 7.4 Other Installation Checks 39
- 8 Initial Start Up Checks and Commissioning Procedure For Warranty Inspection 41**
- 9 Maintenance 43**
- 9.1 Filters 44
 - 9.1.1 Replacing the Filters 44
- 9.2 Fan Maintenance 45
 - 9.2.1 Fan Assembly Troubleshooting 45
 - 9.2.2 Fan Impellers 46
 - 9.2.3 Backdraft Barrier Kits 47
 - 9.2.4 Removing Fan Assembly 48
- 9.3 Condensate Drain System Maintenance 54
 - 9.3.1 Condensate Drain 54
 - 9.3.2 Condensate Pump 54
 - 9.3.3 Coil Drain Plug 54
 - 9.3.4 Facility Fluid and Piping Maintenance 55
 - 9.3.5 Glycol Solution Maintenance 55
- 10 Preventive Maintenance Checklist 57**
- Appendices 61**
- Appendix A: Technical Support and Contacts 61
- Appendix B: Flange Specifications 63
- Appendix C: Submittal Drawings 65
- Appendix D: Seismic Application 67
- Appendix E: Guide Specifications 69

1 Important Safety Instructions

SAVE THESE INSTRUCTIONS

This manual contains important safety instructions that should be followed during the installation and maintenance of the Vertiv™ Liebert® CWA. Read this manual thoroughly before attempting to install or operate this unit.

Only qualified personnel should move, install, or service this equipment.

Adhere to all warnings, cautions, notices and installation, operating and safety instructions on the unit and in this manual. Follow all installation, operation and maintenance instructions and all applicable national and local building, electrical and plumbing codes.



WARNING! Arc flash and electric shock hazard. Open all local and remote electric power supply disconnect switches, verify with a voltmeter that power is Off and wear appropriate, OSHA-approved personal protective equipment (PPE) per NFPA 70E before working within the electric control enclosure. Failure to comply can cause serious injury or death. Customer must provide earth ground to unit, per NEC, CEC and local codes, as applicable. Before proceeding with installation, read all instructions, verify that all the parts are included and check the nameplate to be sure the voltage matches available utility power. The Vertiv™ Liebert® iCOM™ controller does not isolate power from the unit, even in the “Unit Off” mode. Some internal components require and receive power even during the “Unit Off” mode of the controller. The only way to ensure that there is NO voltage inside the unit is to install and open a remote disconnect switch. Refer to unit electrical schematic. Follow all local codes.



WARNING! Risk of electric shock. Can cause equipment damage, injury or death. Open all local and remote electric power supply disconnect switches and verify with a voltmeter that power is off before working within any electric connection enclosures. Installation, service, and maintenance work must be performed only by properly trained and qualified personnel and in accordance with applicable regulations and manufacturers’ specifications. Opening or removing the covers to any equipment may expose personnel to lethal voltages within the unit even when it is apparently not operating and the input wiring is disconnected from the electrical source.



WARNING! Risk of electric shock. Can cause serious injury or death. The Vertiv™ Liebert® iCOM™ microprocessor does not isolate power from the unit, even in the "Unit Off" mode. Some internal components require and receive power even during the "unit off" mode of the Vertiv™ Liebert® iCOM™ control. Open all local and remote electric power disconnect switches and verify with a voltmeter that power is Off before working on any component of the system.



WARNING! Risk of electric shock. Can cause injury or death. Open all local and remote electric power supply disconnect switches and verify that power is Off with a voltmeter before working within the condensate pump electrical connection enclosure. The Vertiv™ Liebert® iCOM™ does not isolate power from the unit, even in the “Unit Off” mode. Some internal components require and receive power even during the “Unit Off” mode of the Vertiv™ Liebert® iCOM™.



WARNING! Risk of improper moving. Can cause equipment damage, injury, or death. Use only lifting equipment that is rated for the unit weight by an OSHA-certified rating organization.



WARNING! Risk of improper moving, lifting, or handling of the unit. Can cause equipment damage, injury or death. Read all of the following instructions and verify that all lifting and moving equipment is rated for the weight of the unit before attempting to move, lift, remove packaging from or prepare the unit for installation. Shipping weights and unit weights are listed in DPN005036.



WARNING! Risk of top-heavy unit falling over. Improper handling can cause equipment damage, injury or death. The center of gravity varies depending on the unit size and selected options. Shipping weights and unit weights are specified in DPN005036.



WARNING! Risk of improper wire sizing/rating and loose electrical connections. Can cause overheated wire and electrical connection terminals resulting in smoke, fire, equipment and building damage, injury or death. Use correctly sized copper wire only and verify that all electrical connections are tight before turning power On. Check all electrical connections periodically and tighten as necessary.



WARNING! Risk of contact with high speed rotating fan blades. Can cause serious injury or death. Open all local and remote electric power supply disconnect switches, verify with a voltmeter that power is off, and verify that all fan blades have stopped rotating before working in the unit cabinet or on the fan assembly. If control voltage is applied, the fan motor can restart without warning after a power failure. Do not operate the unit with any or all cabinet panels removed.



WARNING! Risk of improper wiring, piping, moving, lifting and handling. Can cause equipment damage, serious injury or death. Installation and service of this equipment should be done only by qualified personnel who have been specially trained in the installation of air conditioning equipment and who are wearing appropriate, OSHA-approved PPE.



CAUTION: Risk of contact with sharp edges, splinters, and exposed fasteners. Can cause injury. Only properly trained and qualified personnel wearing appropriate, OSHA-approved PPE should attempt to move, lift, remove packaging from or prepare the unit for installation.



CAUTION: Risk of exposure to harmful noise levels. Can cause hearing injury or loss. Depending on the installation and operating conditions, a sound pressure level greater than 70 dB(A) may arise. Take appropriate technical safety measures. Operating personnel must wear appropriate, OSHA-approved PPE and observe all appropriate hearing-protection safety requirements.



CAUTION: Risk of contact with hot surfaces. Can cause injury. The fan motor and some electrical components are extremely hot during unit operation. Allow sufficient time for them to cool to a touch-safe temperature before working within the unit cabinet. Use extreme caution and wear appropriate, OSHA-approved PPE when working on or near hot components.



CAUTION: Risk of improper piping installation, leak checking, fluid chemistry, and fluid maintenance can cause equipment damage and personal injury. Installation and service of this equipment should be done only by qualified personnel who are wearing appropriate, OSHA-approved PPE.

NOTICE

Risk of improper power supply connection. Can cause equipment damage and loss of warranty coverage.

Prior to connecting any equipment to a main or alternate power source (for example: backup generator systems) for start up, commissioning, testing, or normal operation, ensure that these sources are correctly adjusted to the nameplate voltage and frequency of all equipment to be connected. In general, power source voltages should be stabilized and regulated to within $\pm 10\%$ of the load nameplate nominal voltage. Also, ensure that no three-phase sources are single phased at any time.

NOTICE

Risk of piping-system corrosion and freezing fluids. Can cause leaks resulting in equipment and very expensive building damage. Cooling coils and piping systems are at high risk of freezing and premature corrosion. Fluids in these systems must contain the proper antifreeze and inhibitors to prevent freezing and premature coil and piping corrosion. The water or water/glycol solution must be analyzed by a competent local water treatment specialist before start up to establish the inhibitor and antifreeze solution requirement and at regularly scheduled intervals throughout the life of the system to determine the pattern of inhibitor depletion.

The complexity of water/glycol solution condition problems and the variations of required treatment programs make it extremely important to obtain the advice of a competent and experienced water treatment specialist and follow a regularly scheduled coolant fluid system maintenance program.

Water chemistry varies greatly by location, as do the required additives, called inhibitors, that reduce the corrosive effect of the fluids on the piping systems and components. The chemistry of the water used must be considered, because water from some sources may contain corrosive elements that reduce the effectiveness of the inhibited formulation. Sediment deposits prevent the formation of a protective oxide layer on the inside of the coolant system components and piping. The water/coolant fluid must be treated and circulating through the system continuously to prevent the buildup of sediment deposits and or growth of sulfate reducing bacteria.

Proper inhibitor maintenance must be performed in order to prevent corrosion of the system. Consult glycol manufacturer for testing and maintenance of inhibitors.

Commercial ethylene glycol, when pure, is generally less corrosive to the common metals of construction than water itself. It will, however, assume the corrosivity of the water from which it is prepared and may become increasingly corrosive with use if not properly inhibited.

We recommend installing a monitored fluid detection system that is wired to activate the automatic-closure of field-installed coolant-fluid supply and return shutoff valves to reduce the amount of coolant-fluid leakage and consequential equipment and building damage. The shutoff valves must be sized to close off against the maximum coolant-fluid system pressure in case of a catastrophic fluid leak.

NOTICE

Risk of frozen pipes and corrosion from improper coolant mixture. Can cause water leaks resulting in equipment and building damage.

When the cooling unit or piping may be exposed to freezing temperatures, charge the system with the proper percentage of glycol and water for the coldest design ambient temperature. Automotive antifreeze is unacceptable and must NOT be used in any glycol fluid system. Use only HVAC glycol solution that meets the requirements of recommended industry practices. Do not use galvanized pipe.

NOTICE

Risk of no flow condition. Can cause equipment damage.

Do not leave the water/coolant fluid supply circuit in a no-flow condition. Idle fluid allows the collection of sediment that prevents the formation of a protective oxide layer on the inside of tubes. Keep unit switched On and water/coolant fluid supply circuit system operating continuously.

NOTICE

Risk of clogged or leaking drain lines and leaking water supply lines. Can cause equipment and building damage.

This unit requires a water drain connection. Drain lines must be inspected at start-up and periodically, and maintenance must be performed to ensure that drain water runs freely through the drain system and that lines are clear and free of obstructions and in good condition with no visible sign of damage or leaks. This unit may also require an external water supply to operate.

Improper installation, application and service practices can result in water leakage from the unit. Water leakage can result in catastrophic and expensive building and equipment damage and loss of critical data center equipment.

Do not locate unit directly above any equipment that could sustain water damage.

We recommend installing a monitored fluid detection system to immediately discover and report coolant-fluid system and condensate drain line leaks.

NOTICE

Risk of doorway/hallway interference. Can cause unit and/or structure damage. The unit may be too large to fit through a doorway or hallway while on or off skid. Measure the unit and passageway dimensions, and refer to the installation plans prior to moving the unit to verify clearances.

NOTICE

Risk of damage from forklift. Can cause unit damage. Keep tines of the forklift level and at a height suitable to fit below the skid and/or unit to prevent exterior and/or underside damage.

NOTICE

Risk of improper storage. Can cause unit damage.

Keep the unit upright, indoors and protected from dampness, freezing temperatures and contact damage.

This page intentionally left blank

2 Nomenclature and Components

This section describes the model number for Vertiv™ Liebert® CWA units and components.

2.1 Vertiv™ Liebert® CWA Model Number Nomenclature

Table 2.4 below describes each digit of the configuration number. The Vertiv™ Liebert® CWA 'system' consists of a bottom and top module. There is one unique configuration number for the system, while there is a unique model number for the bottom module and another unique model number for the top module.

The 14 digit Model Number is comprised of the first 10 digits (digits 1-10) and the last 4 digits (configuration digits 37-40) of the Configuration Number.

An example of a Liebert CWA Configuration Number would be:

CA608BF1AB02081SSDBFP0000POPC0000000A903

An example of the model numbers for the Liebert CWA would be:

Bottom Module Model Number: CA608BF1ABA903

Top Module Model Number: CA608BF1ATA903

Table 2.1 Configuration Number Breakdown Digits 1 to 20 (example)

1	2	3	4	5	6	7	8	9	10	11	12	13	14	15	16	17	18	19	20
C	A	6	0	8	B	F	1	A	B	0	2	0	8	1	S	S	D	B	F

Table 2.2 Configuration Number Breakdown Digits 21 to 40 (example)

21	22	23	24	25	26	27	28	29	30	31	32	33	34	35	36	37	38	39	40
P	0	0	0	0	P	0	P	C	0	0	0	0	0	0	0	A	9	0	3

Table 2.3 Model Number Breakdown (example)

1	2	3	4	5	6	7	8	9	10	11	12	13	14
C	A	6	0	8	B	F	1	A	B	A	9	0	3

Table 2.4 Vertiv™ Liebert® CWA Configuration Number Digit Definitions

Digit	Description
1, 2—Vertiv™ Liebert® CWA	CA
3, 4—Model	60
5—Coil Rows	4 = 4 Row 6 = 6 Row

Table 2.4 Vertiv™ Liebert® CWA Configuration Number Digit Definitions (continued)

Digit	Description
	8 = 8 Row
6—Fan Type	4 = Standard Axial Fan 5 = Standard Axial Fan + THD A = High Airflow, High Efficiency Fan B = High Airflow, High Efficiency Fan + THD
7—Customer Connection Type	F = Flanged B = Brazed
8—Valve Type	1 = 2-way fail in place 4 = 2-way fail open 5 = 2-way fail closed
9—Power Supply	A = 460/3/60 B = 575/3/60 2 = 380/3/60 M = 380-414/3/50
10—Module	B = Bottom (base) module T = Top module
11—	0 = Placeholder
12—Display/Microprocessor Control	2 = Vertiv™ Liebert® iCOM™ (high definition)
13—	0 = Placeholder
14—Air Filter	8 = 4" MERV 8 9 = 4" MERV 11 0 = None
15—Coil	1 = Non-coated coils
16—Seismic	0 = None S = Seismic (IBC Sds 0.75) C = Seismic (IBC Sds 2.5)
17—High Voltage Options	L = Locking Disconnect + Quick Start Enabled C = Locking Disconnect + Capacitive Buffer + Quick Start Enabled R = Dual Locking Disconnect with Reversing Starter + Quick Start Enabled S = Dual Locking Disconnect with Reversing Starter + Capacitive Buffer + Quick Start
18—Options Packages	0 = None L = Low voltage terminal package D = Low voltage terminal package plus remote humidifier contact
19—Monitoring	B = Base Comms and Connectivity
20—Sensors	0 = None

Table 2.4 Vertiv™ Liebert® CWA Configuration Number Digit Definitions (continued)

Digit	Description
	S = Smoke H = High temperature F = Smoke and high temperature
21—Packaging	P = Domestic packaging C = Export packaging
22 - 25	O = Placeholder
26	O = None P = Power Meter
27—Additional Monitoring Options	O = None L = LT460 (Mounted & Installed)
28—Additional Sensors	O = None P = Static Pressure Fan Control (Mounted & Installed)
29—Condensate pump	O = None C = Condensate pump
30—Internal/external sensor	O = None 3 = 30 ft (9.1 m) Remote temperature and humidity sensor 6 = 60 ft (18.3 m) Remote temperature and humidity sensor 9 = 90 ft (27.4 m) Remote temperature and humidity sensor 2 = 120 ft (36.6 m) Remote temperature and humidity sensor 5 = 150 ft (45.7 m) Remote temperature and humidity sensor
31-36	O = Placeholder
37—Configuration Code	A = No SFA S = SFA
38-40—Factory Configuration Number	Factory configuration code

2.2 Component Location

The unit component locations are described in the submittal documents included in the [Submittal Drawings](#) on page 65 .

The following table lists the relevant documents by number and title.

Table 2.5 Component Location Drawings

Document Number	Title
DPN005204	Component Location Diagram with Standard Axial Fan
DPN005141	Component Location Diagram with High Airflow/High Efficiency Fan

2.3 Vertiv™ Liebert® CWA Physical Data

Table 2.6 Physical Data

Model Number	Without THD With THD (optional)	CA6044 CA6045	CA6064 CA6065	CA6084 CA6085	CA604A CA604B	CA606A CA606B	CA608A CA608B
Fan Data - EC Fans							
Coil Rows		4	6	8	4	6	8
Fan Type		Standard Axial Fan			High Airflow, High Efficiency (optional)		
Nominal Air Volume CFM (CMH) @ 0.2" (50 Pa) with MERV8 filters		45,000 (76,455)			45,000 (76,455)		
Coil Face Velocity FPM (m/s)		445 (2.26)			445 (2.26)		
Maximum Air Volume CFM (CMH) @ 0.2" (50 Pa) ESP with MERV8 filters		59,300 (100,751)	56,400 (95,824)	53,600 (91,067)	64,000 (108,737)	62,400 (106,018)	60,800 (103,300)
Coil Face Velocity FPM (m/s)		586 (2.98)	557 (2.83)	530 (2.69)	632 (3.21)	617 (3.13)	601 (3.05)
Fan Motor, Maximum hp (kW), each		4.69 (3.5)			4.96 (3.7)		
Quantity of Fan Motors		4			6		
Chilled Water Coil							
Face Area ft2 (m2)		101.2 (9.4)					
Valve Quantity		2					
2-way Valve Size, in.		2-1/2					
Valve, Cv		60					
Valve Close Off pressure rating psi (kPa)		100 (689)					
Valve ratings psi (kPa)		400 (2,758)					
System Design pressure rating psi (kPa)		270 (1,861)					
Performance data available upon request							
Filter Section							
Disposable Type - Nominal Size and Quantities, MERV8 and MERV11 (optional)							
Nominal Size, in.		20 x 24 x 4					
Quantity		33					
Connection Sizes							
Customer Supply and Return Chilled Water Connection Type		Brazed					
Customer Supply and Return Chilled Water Connection, O.D. Copper		4"					
Customer Supply and Return Chilled Water Connection Flange Size (optional)		4" (150 lb.) Steel Pipe Flange					
Condensate Drain, FPT		3/4"					
Condensate Pump, O.D. Copper (optional)		1/2"					
Weight		See DPN005036					

3 Pre-Installation Preparation and Guidelines

NOTE: Before installing unit, determine whether any building alterations are required to run piping and wiring. Follow all unit dimensional drawings and refer to the submittal engineering dimensional drawings of individual units for proper clearances.

Refer to [Vertiv™ Liebert® CWA Model Number Nomenclature](#) on page 7 and [Submittal Drawings](#) on page 65 to determine the type of system being installed and anticipate building alterations, piping and duct work needed.

The unit dimensions, pipe connection locations, and piping schematics are described in the submittal documents included in the [Submittal Drawings](#) on page 65.

- Verify that the floor is level, solid and sufficient to support the unit. See DPN005036 for shipping dimensions and unit weights.
- Confirm that the room is properly insulated and has a sealed vapor barrier.
- For proper humidity control, keep outside or fresh air to an absolute minimum (less than 5% of total air circulated in the room).
- Install the units as close as possible to the largest heat load.
- Allow at least the minimum recommended clearances for maintenance and service. See the appropriate submittal drawings for dimensions.
- We recommend installing an under floor water detection system. Contact your Vertiv representative for information.

3.1 Planning Dimensions

The unit dimensions are described in the submittal documents included in the [Submittal Drawings](#) on page 65.

Relevant documents are referenced below by number and title.

Table 3.1 Dimension Planning Drawings

Document Number	Title
DPN005036	Cabinet and Anchor Dimensional Data, Bottom and Top Modules
DPN005165	Installation and Service Clearance
DPN005179	Floor Planning for Adjacent Units
DPN005037	Airflow Schematic

3.2 Connections and System Setup

- The unit requires a drain, which must comply with all applicable codes. See [Field Installed, Gravity Drain Line Requirements](#) on page 34 for details.
- The unit requires supply and return water connections, which must comply with all applicable codes. See [Piping Requirements](#) on page 33.
- If seismic requirements apply, refer to documents in **Table 3.2** below.

Relevant documents are referenced below by number and title.

Table 3.2 Seismic Drawings

Document Number	Title
DPN005198	Seismic Application Assumptions and Requirements, IBC 0.75 Sds
DPN003870	Seismic Application Assumptions and Requirements, IBC 2.5 Sds

3.3 Operating Conditions

The Vertiv™ Liebert® CWA must be operated in a conditioned space within the operating envelope that ASHRAE recommends for data centers. Operating the Vertiv™ Liebert® CWA outside of this envelope can decrease equipment reliability. Refer to ASHRAE's publication, "Thermal Guidelines for Data Processing Environments."

The recommended maximum for return air temperature is 105°F (40°C) and maximum dew point is 59°F (15°C). The recommended minimum return air temperature setpoint for the Vertiv™ Liebert® CWA is 85°F (29.4°C).

3.3.1 Humidification Control

The humidifier option is not available on the Vertiv™ Liebert® CWA. An optional remote humidifier contact is available for a stand-alone humidifier.

3.4 Shipping Dimensions and Unit Weights

See submittal DPN005036 for weights and dimensions (dry, operating and shipping).

3.5 Site Preparation

Prepare the site for installation prior to the arrival and unloading of the unit.

- If installing the unit on a concrete slab or housekeeping pad, sweep the concrete clean and mark the final position of the unit(s) on the slab.
- Verify that all required clearances as specified by Vertiv are met.
- Mark the direction of the final unit placement to avoid accidental reversal of the unit.
- Protect stub outs for electric conduit and any projects against damage and clearly mark their locations.
- Locate and mark the high point on the slab. This step is critical for the placement of multiple, joined units.
- If installing on a structural steel support structure, verify suitability of the supports beneath the unit(s).

3.5.1 Preparing a Concrete Slab

Prepare the concrete slab by locating and marking the high point to assist with shimming the unit. The unit must be installed level.

1. Sweep the slab broom clean.
2. Lay out the final location of the unit on the slab using either chalk line or tape.
3. Using a laser level or an optical level, locate the high point on the slab and mark it.

See **Figure 3.1** below .

Figure 3.1 Unit and High Point Marking on Concrete Slab

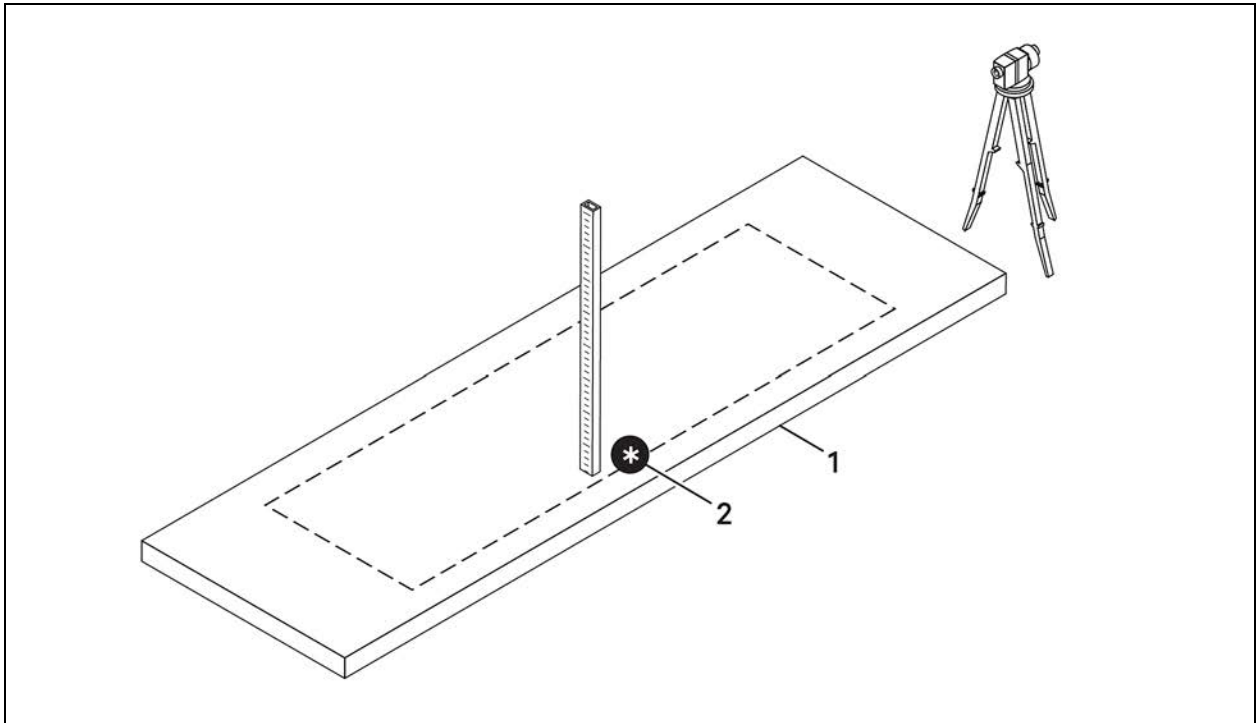

Item	Description
1	Concrete slab
2	High point

This page intentionally left blank

4 Equipment Inspection and Handling and Installation



WARNING! Risk of top heavy unit falling over. Improper handling can cause equipment damage, injury or death. Read all of the following instructions and verify that all lifting and moving equipment is rated for the weight of the unit before attempting to move, lift, remove packaging from or prepare the unit for installation. Unit weights are specified in DPN005036.



WARNING! Risk of improper moving. Can cause equipment damage, injury or death. Use only lifting equipment that is rated for the unit weight by an OSHA-certified rating organization. The center of gravity varies depending on the module. Shipping weights and unit weights are listed in DPN005036.



CAUTION: Risk of contact with sharp edges, splinters, and exposed fasteners. Can cause injury. Only properly trained and qualified personnel wearing appropriate, OSHA-approved PPE should attempt to move, lift, remove packaging from or prepare the unit for installation.

NOTICE

Risk of passageway interference. Can cause unit and/or structure damage. The unit may be too large to fit through a passageway while on or off the skid. Measure the unit and passageway dimensions, and refer to the installation plans prior to moving the unit to verify clearances.

NOTICE

Risk of damage from forklift. Can cause unit damage. Keep tines of the forklift level and at a height suitable to fit below the skid and/or unit to prevent exterior and/or underside damage.

NOTICE

Risk of improper storage. Keep the unit upright, indoors and protected from dampness, freezing temperatures and contact damage.

Upon arrival of the unit and before unpacking:

- Verify that the labeled equipment matches the bill of lading.
- Carefully inspect all items for visible or concealed damage.
- Report damage immediately to the carrier and file a damage claim sent to Vertiv™ or to your sales representative.

Appropriate sized forklift is to be used while moving packaged modules. Equipment used for installation is to be determined by professional riggers.

4.1 Packaging Material



All material used to package this unit is recyclable. Please save for future use or dispose of the material appropriately.

4.2 Handling the Modules While Packaged

The top and bottom modules are shipped as separate units and must be unpacked as separate units.

NOTE: A professional rigger is required to lift and assemble the top and bottom modules as well as to move the assembled unit into place.

Transport modules with a forklift rated for the weight of the unit. Refer to DPN005036 for shipping dimensions and unit weights.

When using a forklift:

- Ensure that the fork length is suitable for the unit length and, if adjustable, spread to the widest allowable distance that will fit under the skid.
- When moving the packaged unit, lift the unit from the end and do not lift the unit any higher than 4 in. (102 mm). Ensure that the opposite end of the skid still touches the floor. All personnel except those moving the unit must be kept 12 ft (3.7 m) or more from the unit while it is being moved.
- If the unit must be lifted higher than 4 in. (102 mm), all personnel not directly involved in moving the unit must be 20 ft (5 m) or farther from the unit.

4.3 Unpacking the Modules

Unpacking and preparation of each module includes these steps:

1. Remove the exterior stretch wrap packaging from around the unit and any protective corner and side packaging planks.
2. Remove the filter rack assembly on each module. Filters are removed from the center position of the slotted filter rack. Lift up and out to remove. Refer to **Table 4.1** below and [Submittal Drawings](#) on page 65 .

Relevant documents are referenced below by number and title.

Table 4.1 Filter and Filter Rack Location Drawings

Document Number	Title
DPN005164	Filter and Filter Rack Removal

4.3.1 Filter and Rack Removal

NOTICE

Risk of damage to filter rack. Remove filter racks prior to rigging module and replace after module is set in place.

Removal Process

1. Remove filter from center position of filter rack.
2. Lift filters up and out to remove from rack.
3. Loosen two screws located in slots at top and bottom of each filter rack.

NOTE: Do not remove screws.

4. Lift filter racks up and out to remove.
5. Reverse this position to re-attach filter racks and inserting filter.

4.4 Preparing for Assembly

4.4.1 Top Module Prep on Skid

1. Remove the top module piping access panel to access the internal piping for supply and return connections. The panel is located on the gallery side of the unit. See **Figure 4.1** below and **Figure 4.2** on the next page.

NOTE: Access panel screws have a maximum torque value of 40 in-lbs.

Figure 4.1 Gallery Side, Top Module, Piping Access Panel

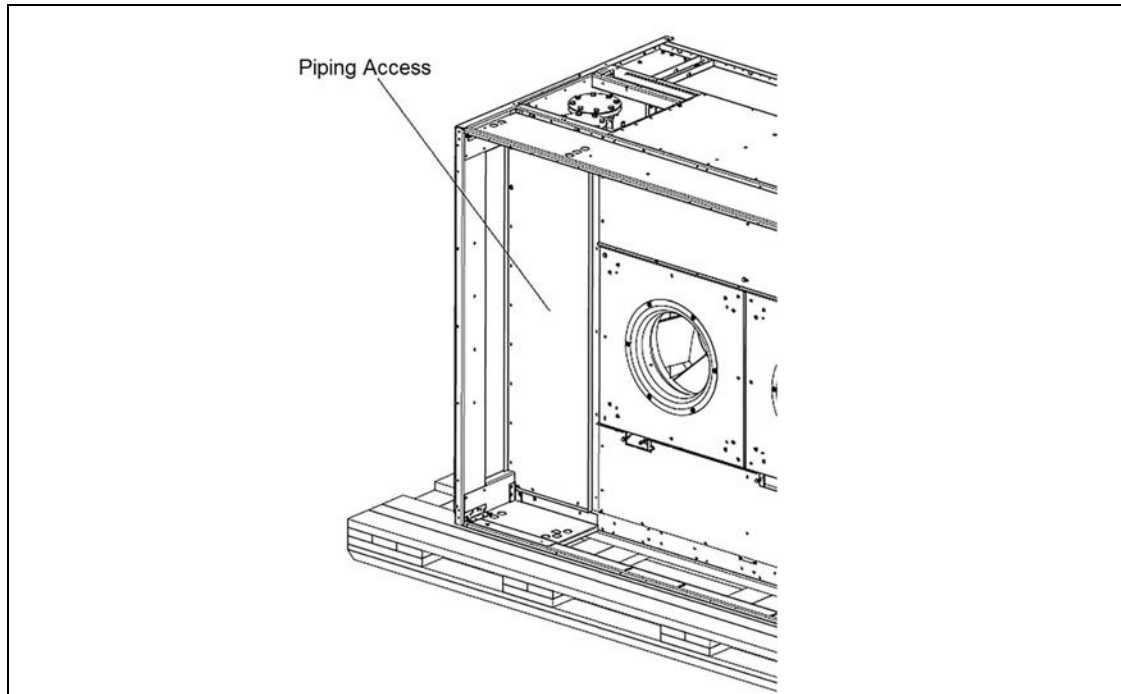
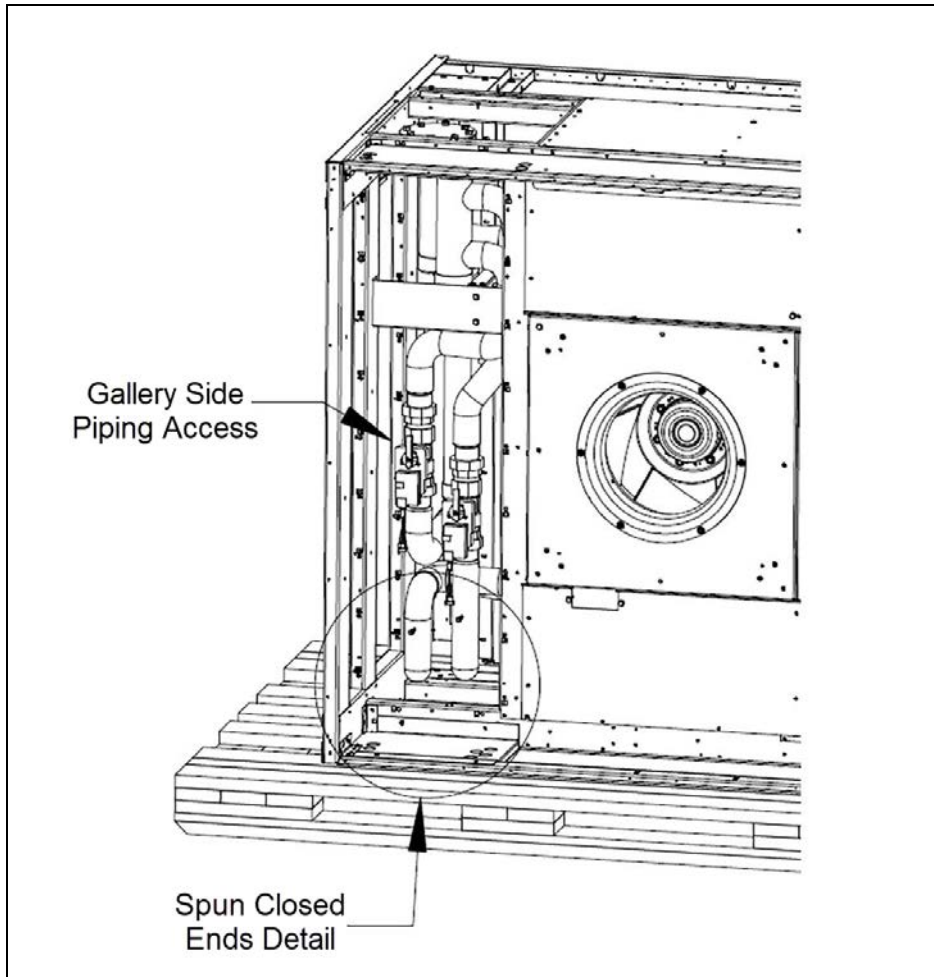

Figure 4.2 Gallery Side, Top Module Piping Access to Internal Supply and Return Piping Connections



2. Before removing any fittings or cutting copper tubing, vent the holding charge by using the Schrader valves provided on the module.
3. Prepare the internal piping connections by removing the spun closed ends and cutting to the specified dimensions. See **Figure 4.2** above and **5.2** on page 31.

4.4.2 Top Module—Venting the Inert Gas Holding Charge

The module is shipped with an inert gas holding charge. Vent the holding charge using the Schrader valve that is provided on the unit before removing any fittings. Refer to DPN005188 Top and Bottom Module Assembly in [Submittal Drawings](#) on page 65 for details.



CAUTION: Use good practice when piping the unit and the system.

Figure 4.3 Spun Closed Ends Detail

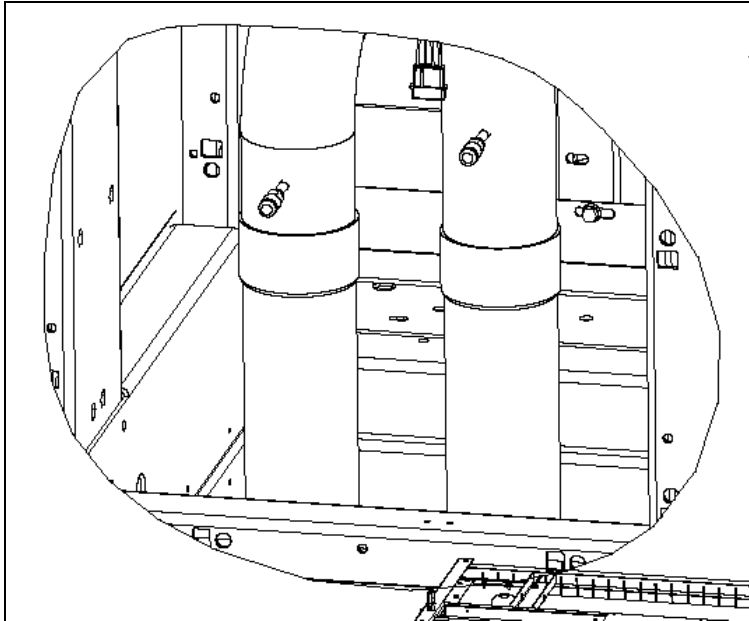

1. Remove any excess piping material using a tube cutter or other non-burring device.
2. Clean up shavings and other materials before making the supply and return piping connections.

Figure 4.4 Dimensions Required for Connection to Bottom Module

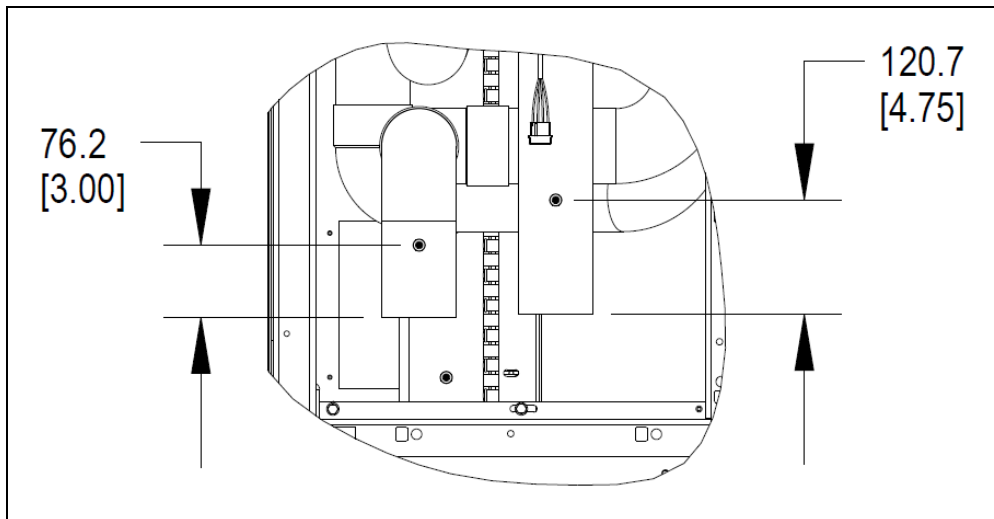

4.4.3 Bottom Module Prep on Skid



CAUTION: Use good practice when piping the unit and the system.

The supply and return pipes protrude above the top of the module. Vent the holding charge using Schrader valves provided on the bottom module before removing the fittings. See **Figure 4.5** on the next page.

Figure 4.5 Bottom Module Supply and Return Pipe Detail

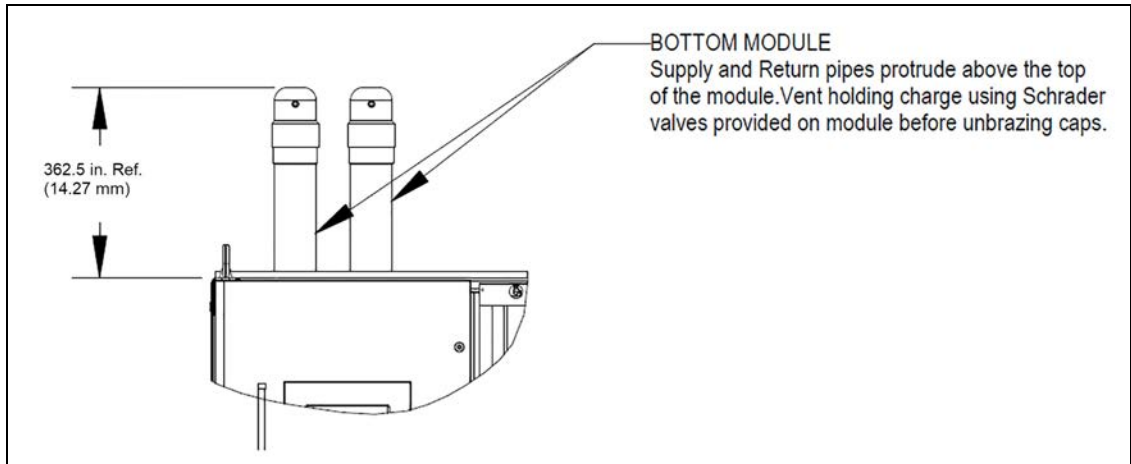

4.4.4 Bottom Module—Venting the Inert Gas Holding Charge

The module is shipped with an inert gas holding charge. Vent the holding charge using the Schrader valve that is provided on the unit before removing any fittings. See Figure 4.5 above.

Figure 4.6 Gallery Side Top Module

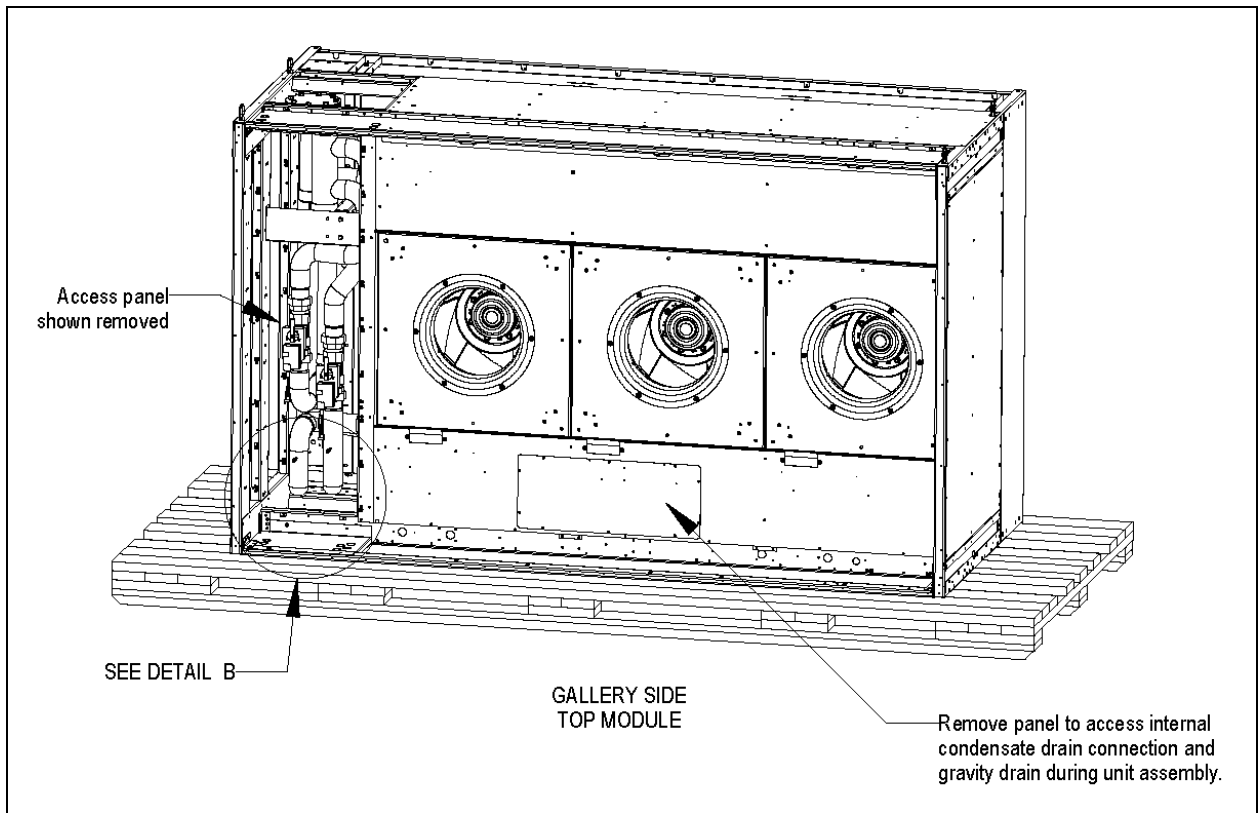

CAUTION: Use good practice when piping the unit and the system.

Before any brazing occurs, make sure that the internal part of the piping joints has been cleaned.

Refer to **Figure 4.7** below

Figure 4.7 Clean Internal Joint Parts, Bottom Module

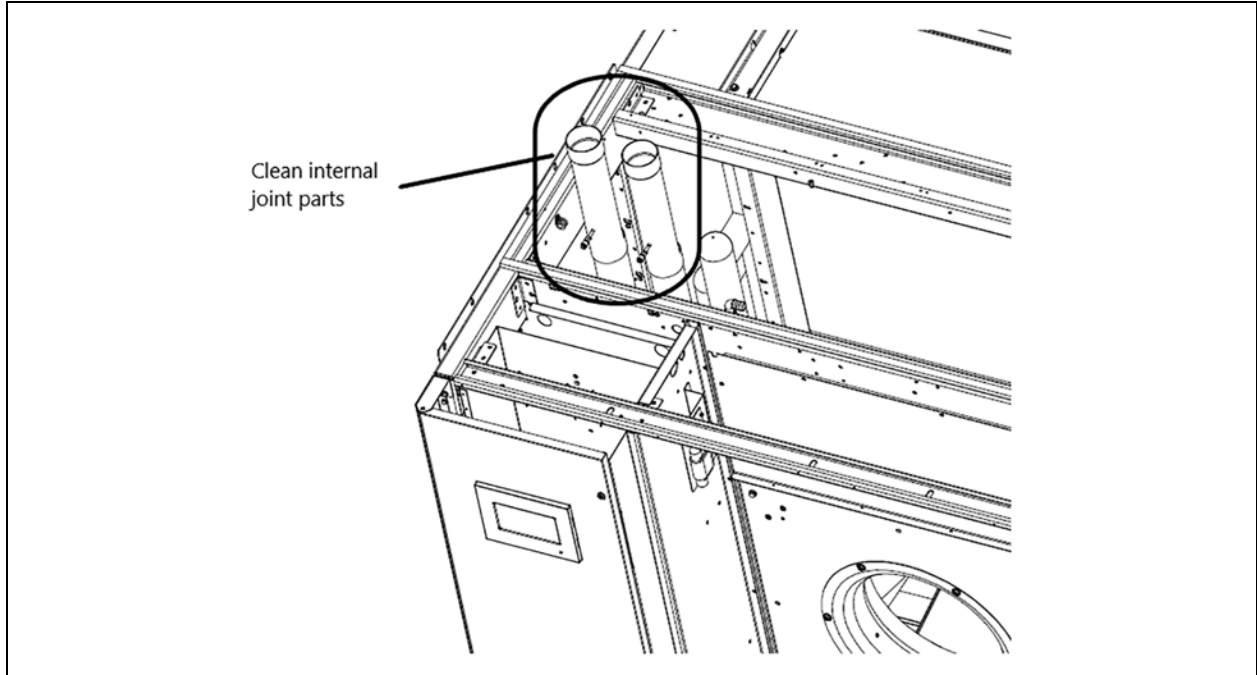

If the Side Gravity Condensate Connection Conversion Kit has been purchased, reference Vertiv document number 10021579 for installation steps. This kit must be installed before the lower module is placed.

Figure 4.8 Installation Clearance

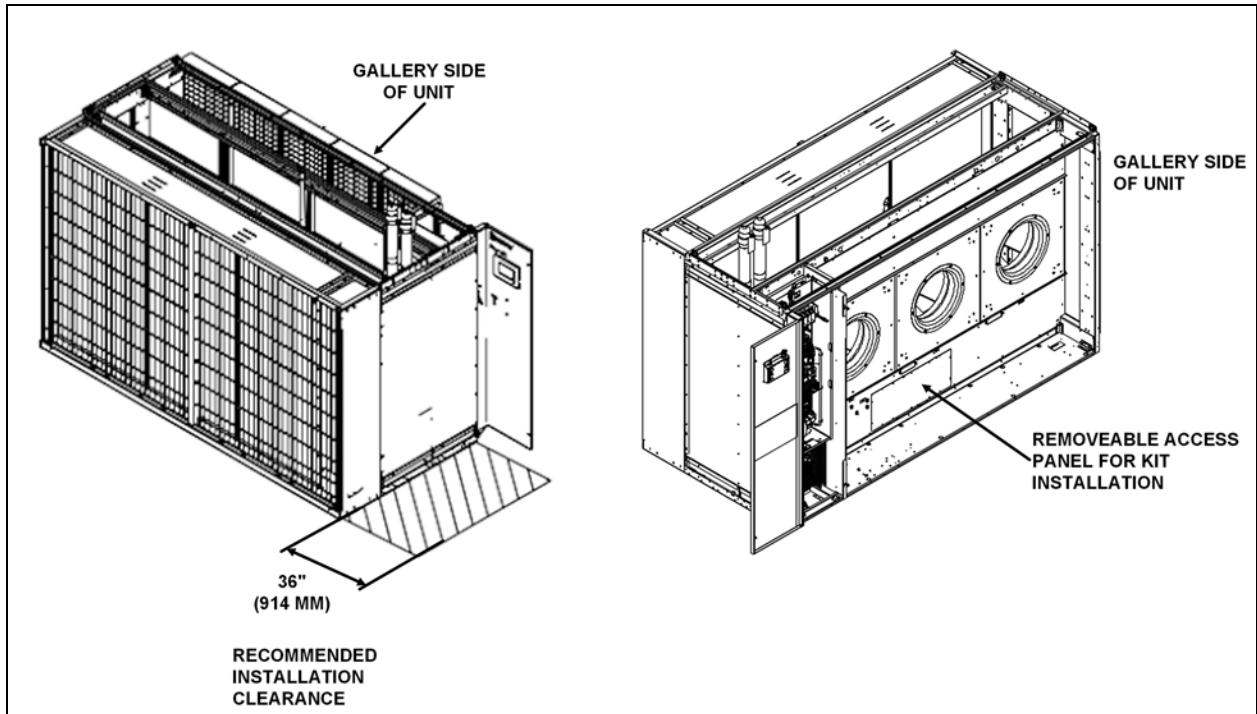

4.4.5 Removing Lag Screw Shipping Fasteners

Both modules are attached to its shipping skid with lag screws.

Use a socket drive to remove the lag screws. There is a total of 7 lag screws per module. The Bottom Module has a quantity of seven (7) 3/8-7 x 1.5 inch lag screws, each with a flat washer. The Top Module has a quantity of three (3) 3/8-7 x 1.5 inch lag screws, and a quantity of four (4) 3/8-7 x 3 inch lag screw; each with a flat washer. See **Figure 4.9** below. If the unit is equipped with Vertiv™ Liebert® Liqui-Tect™ option, the access cover from the bottom module must be removed from the data hall side to locate lag screws. Vertiv™ Liebert® Liqui-Tect™ access cover must be replaced.

Figure 4.9 Lag Screw Removal

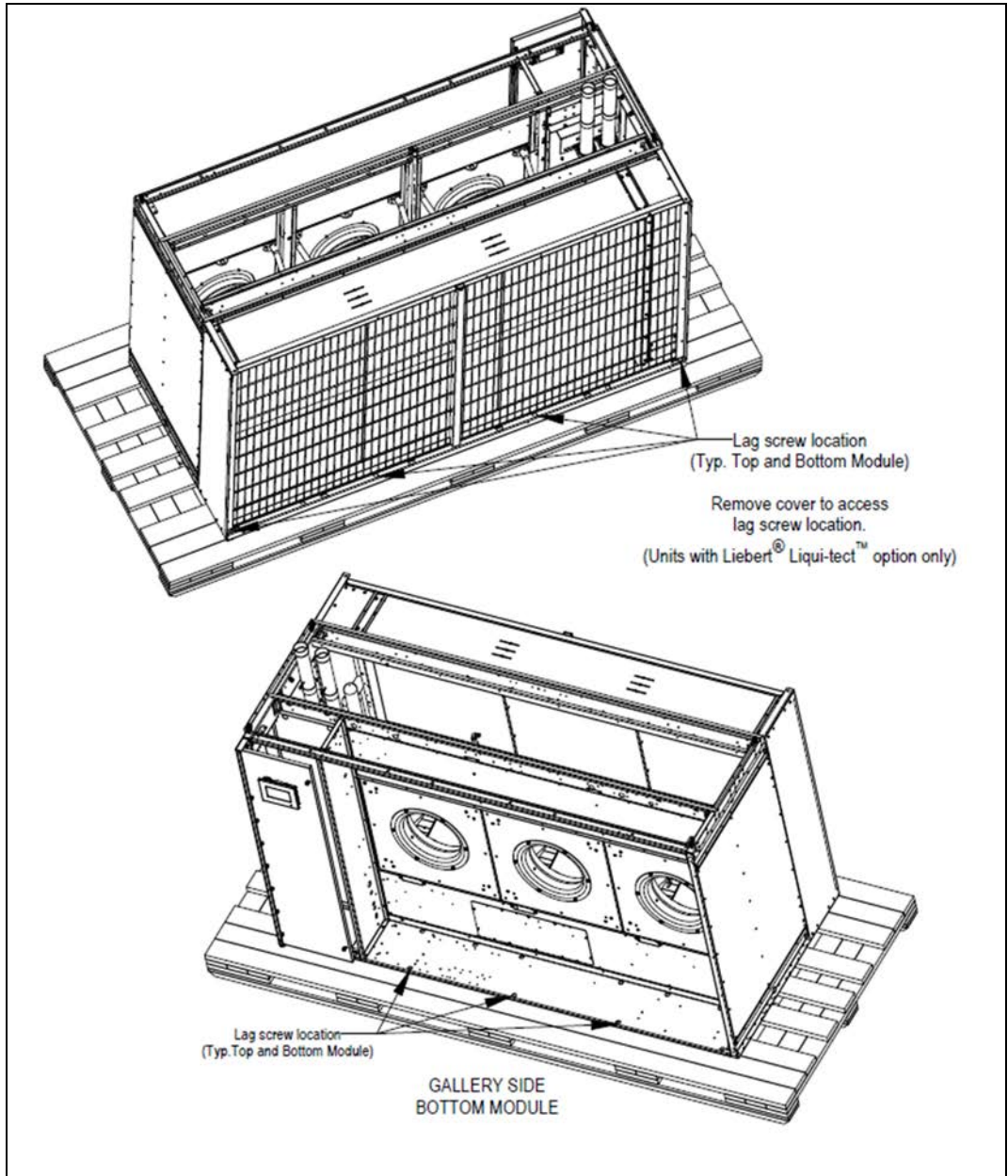

Relevant documents are referenced in **Table 4.2** on the facing page by number and title.

Table 4.2 Lag Screw Drawings

Document Number	Title
DPN005188	Top and Bottom Module Assembly

4.5 Assembly of Top and Bottom Modules

NOTE: A professional rigger is required to lift and assemble the top and bottom modules as well as to move the assembled unit into place. A professional rigger is required to move the assembled unit into place.



CAUTION: Risk of contact with sharp edges, splinters, and exposed fasteners. Can cause injury. Only properly trained and qualified personnel wearing appropriate, OSHA-approved PPE should attempt to move, lift, remove packaging from or prepare the unit for installation. Protect against sharp edges at the lift points of each unit.

Figure 4.10 Lifting Points

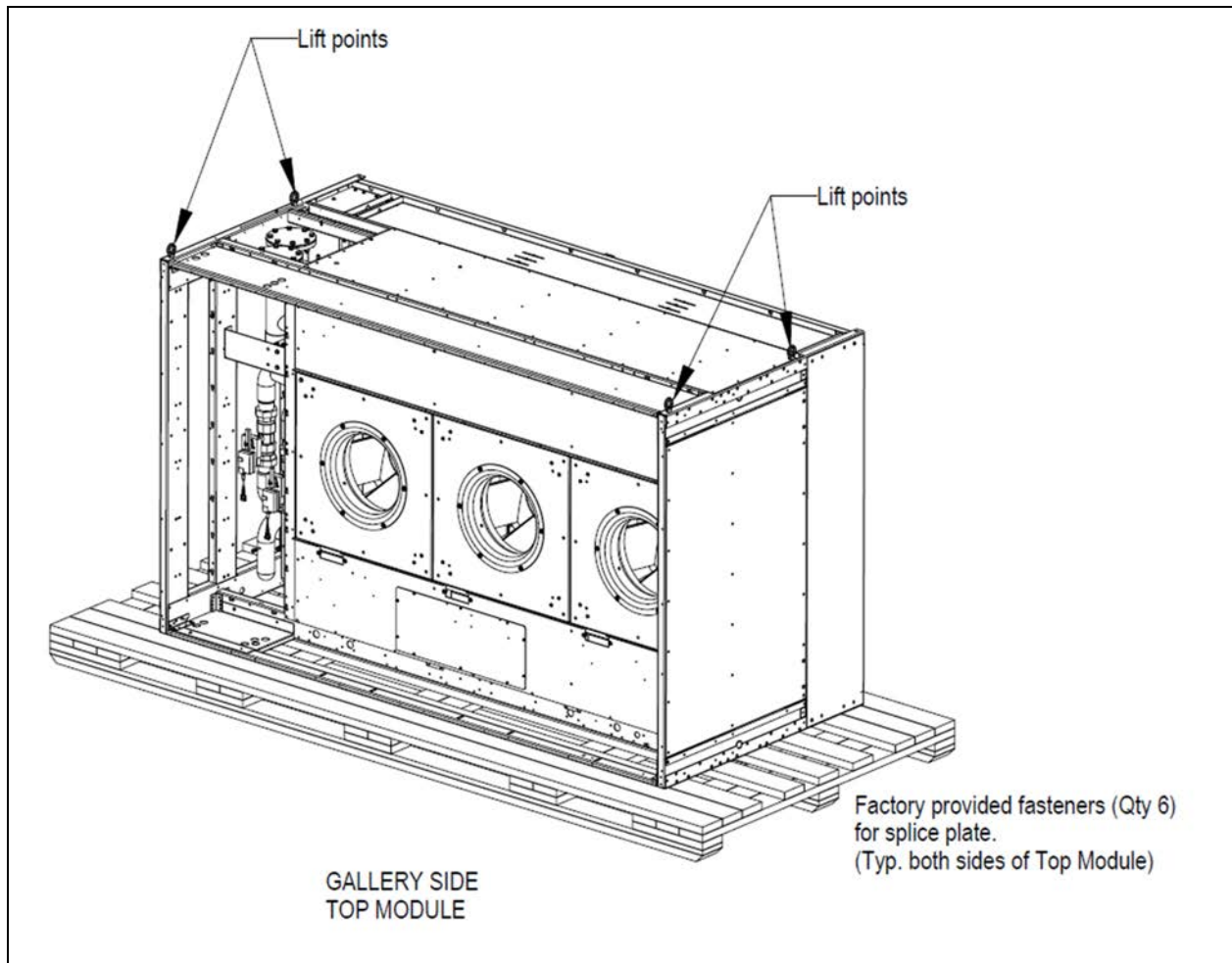

NOTE: Access panel screws have a maximum torque value of 40 in-lbs.

1. Remove the factory provided hardware from both sides of the top module for splice plate attachment.

2. Lifting force must be completely vertical at each lift point location.

4.6 Final Installation

1. Field must use a professional rigger to lift and assemble the top and bottom module.
2. Align and mount top module onto bottom module. If top module is leaning toward the front (data hall) creating a small gap in the rear (gallery) side, where the top and bottom modules meet, use clamps on the rear (gallery) side of the unit to close the gap between modules.
3. Fasten modules together with factory-provided splice plates and fasteners (typical both ends of unit).
4. Braze internal piping connections.
5. Assemble internal condensate connection between top and bottom module. (See DPN005193 for details.)
6. Leak check the assembled unit.
7. Field must use a professional rigger to move the assembled unit into place. (See DPN005036 for bottom module mounting. For seismic rated units, reinstall rear bracing, see **Figure 4.12** on page 26.)
8. Complete electrical connection for the low voltage chilled water valves and then reattach panel covers on the top module piping section and top and bottom module lifting points.
9. Complete electrical connections for top module fans and then reinstall filter racks on top and bottom module.
10. Anchor modules to pad using bolt grade to be specified by local requirements.

See [Submittal Drawings](#) on page 65 .

Figure 4.11 Top and Bottom Module Assembly

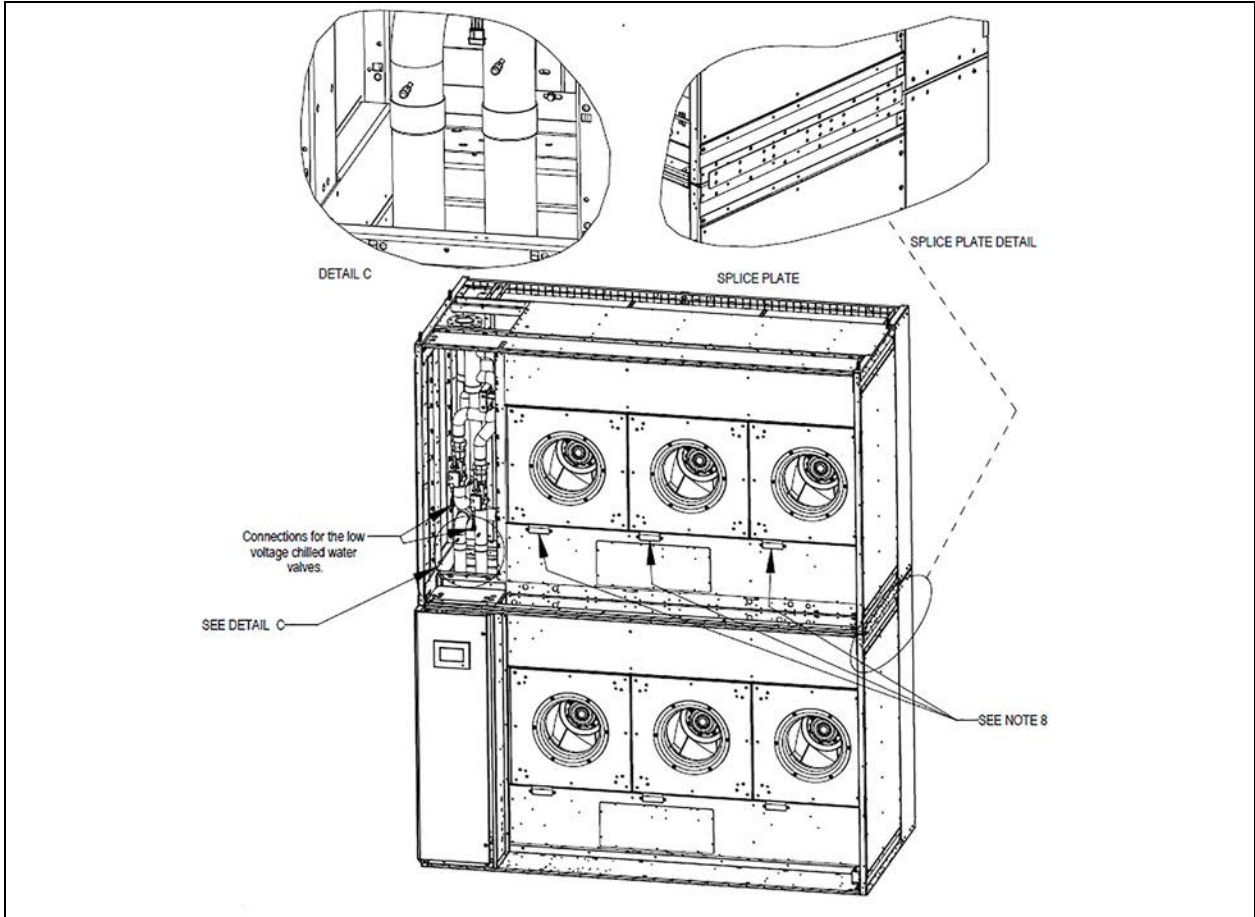
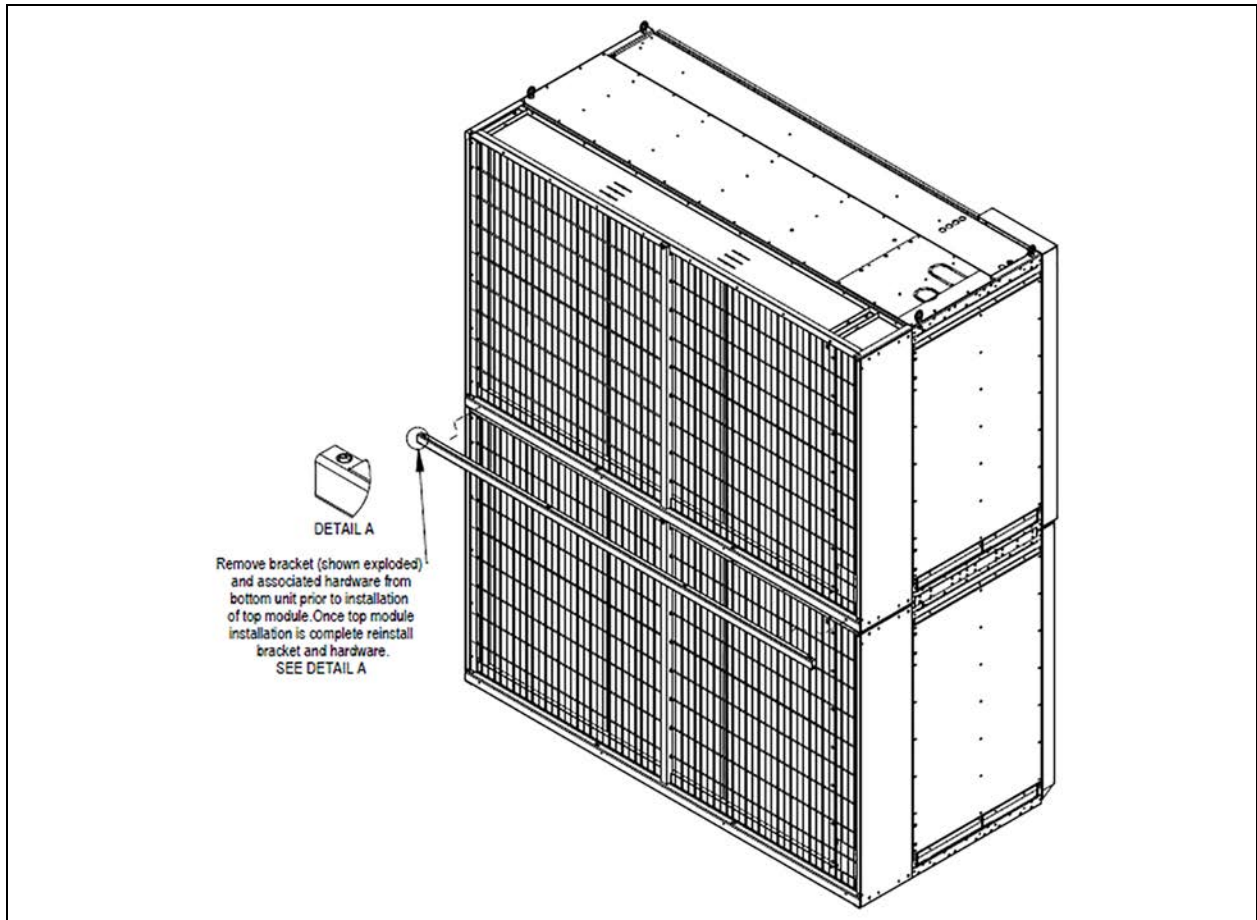

Figure 4.12 External Bracing for Seismic Units



5 Electrical Connections

Three-phase electrical service is required for all models. Electrical service must conform to national and local electrical codes. Refer to equipment nameplate regarding wire size and circuit protection requirements. Refer to electrical schematic when making connections. Refer the appropriate submittal drawing, listed in **Table 5.1** on the next page, for electrical service entrances into unit.

A manual electrical disconnect switch should be installed in accordance with local codes and distribution system. Consult local codes for external disconnect requirements.



WARNING! Arc flash and electric shock hazard. Open all local and remote electric power supply disconnect switches, verify with a voltmeter that power is Off and wear appropriate, OSHA-approved personal protective equipment (PPE) per NFPA 70E before working within the electric control enclosure. Failure to comply can cause serious injury or death. Customer must provide earth ground to unit, per NEC, CEC and local codes, as applicable. Before proceeding with installation, read all instructions, verify that all the parts are included and check the nameplate to be sure the voltage matches available utility power. The Vertiv™ Liebert® iCOM™ controller does not isolate power from the unit, even in the “Unit Off” mode. Some internal components require and receive power even during the “Unit Off” mode of the controller. The only way to ensure that there is NO voltage inside the unit is to install and open a remote disconnect switch. Refer to unit electrical schematic. Follow all local codes.



WARNING! Risk of improper wiring, piping, moving, lifting and handling. Can cause equipment damage, serious injury or death. Installation and service of this equipment should be done only by qualified personnel who have been specially trained in the installation of air conditioning equipment and who are wearing appropriate, OSHA-approved PPE.



WARNING! Risk of improper wire sizing/rating and loose electrical connections. Can cause overheated wire and electrical connection terminals resulting in smoke, fire, equipment and building damage, injury or death. Use correctly sized copper wire only and verify that all electrical connections are tight before turning power On. Check all electrical connections periodically and tighten as necessary.

NOTICE

Risk of improper power supply connection. Can cause equipment damage and loss of warranty coverage.

Prior to connecting any equipment to a main or alternate power source (for example: backup generator systems) for start up, commissioning, testing, or normal operation, ensure that these sources are correctly adjusted to the nameplate voltage and frequency of all equipment to be connected. In general, power source voltages should be stabilized and regulated to within $\pm 10\%$ of the load nameplate nominal voltage. Also, ensure that no three-phase sources are single phased at any time.

See transformer label for primary tap connections. Installer will need to change transformer primary taps if applied unit voltage is other than pre-wired tap voltage.

The electrical and unit to unit connections are described in the submittal documents included in the [Submittal Drawings](#) on page 65.

Relevant documents are referenced below by number and title.

Table 5.1 Electrical Field Connection Drawings

Document Number	Title
DPN005143	Electrical Field Connections, Bottom and Top Modules
DPN005195	Electrical Data (FLA, WSA, OPD)
DPN005187	Primary Connection Locations with Brazed Connections
DPN005038	Primary Connection Locations with Flanged Customer Connections
Automatic Transfer Switch (ATS)	
DPN005196	Auto Transfer Switch (ATS)
THD Transformer	
DPN005208	THD Transformer for Standard Axial Fan
DPN005211	THD Transformer for High Airflow, High Efficiency Fan
Unit to Unit Networking	
DPN004351	Vertiv™ Liebert® iCOM™ Unit to Unit Network Connections
Temperature and Humidity Sensor	
DPN003269	2T Rack Temperature Sensor Connection
DPN000960	Remote Temperature and Humidity Sensor

5.1 Low Voltage Liqui-Tech Sensor Location

The LT460 provides zone leak coverage within the bottom module by utilizing a leak detection cable. A cable termination sensor box is powered by 24 VAC from the Vertiv™ Liebert® CWA unit with two Form-C dry contact common alarm relay outputs rated at 24 VAC, 3 Amp to remotely signal leak detected, loss of power and cable fault. See **Figure 5.1** below and **Figure 5.2** on the next page .

Figure 5.1 LT460 Sensor Location

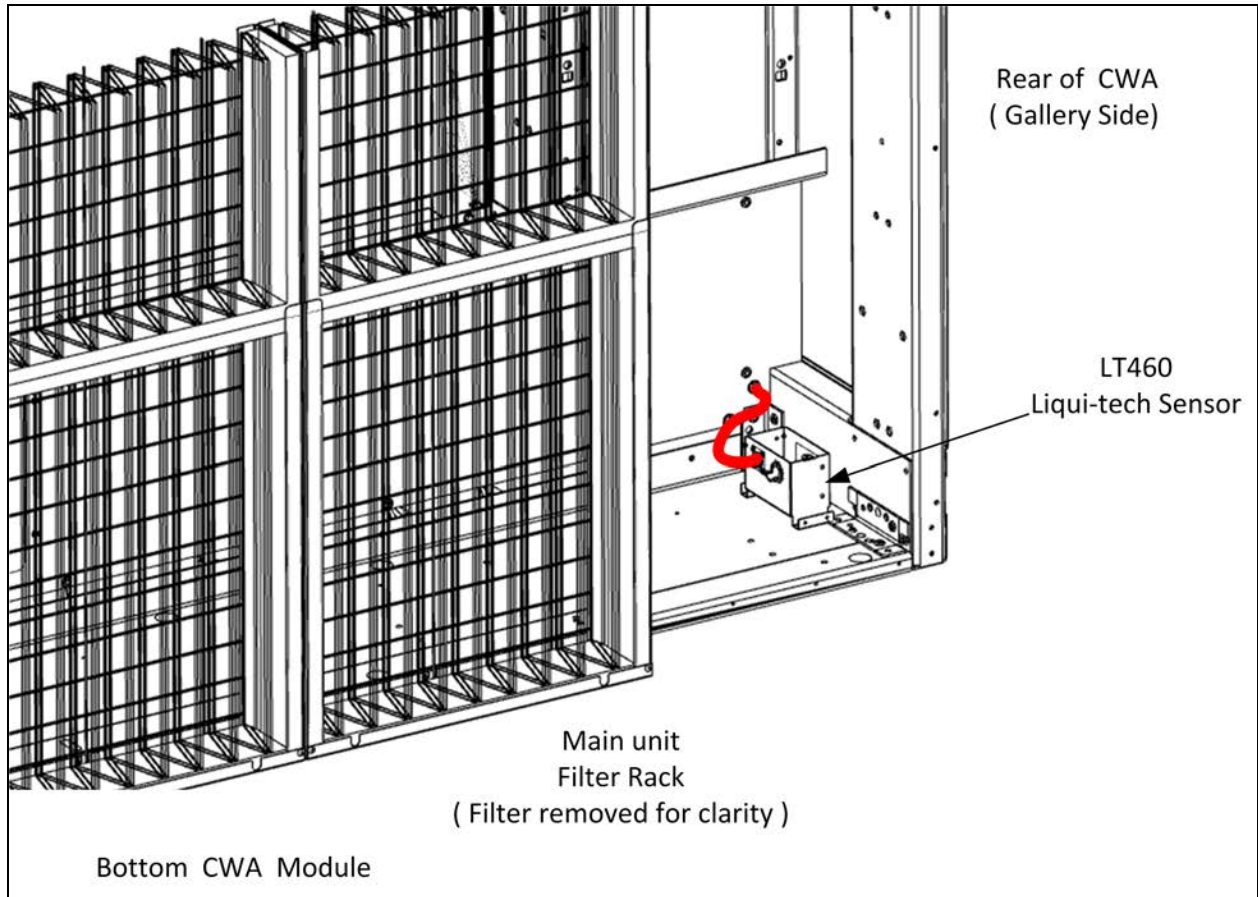

Figure 5.2 Approximate Cable Routing LT460

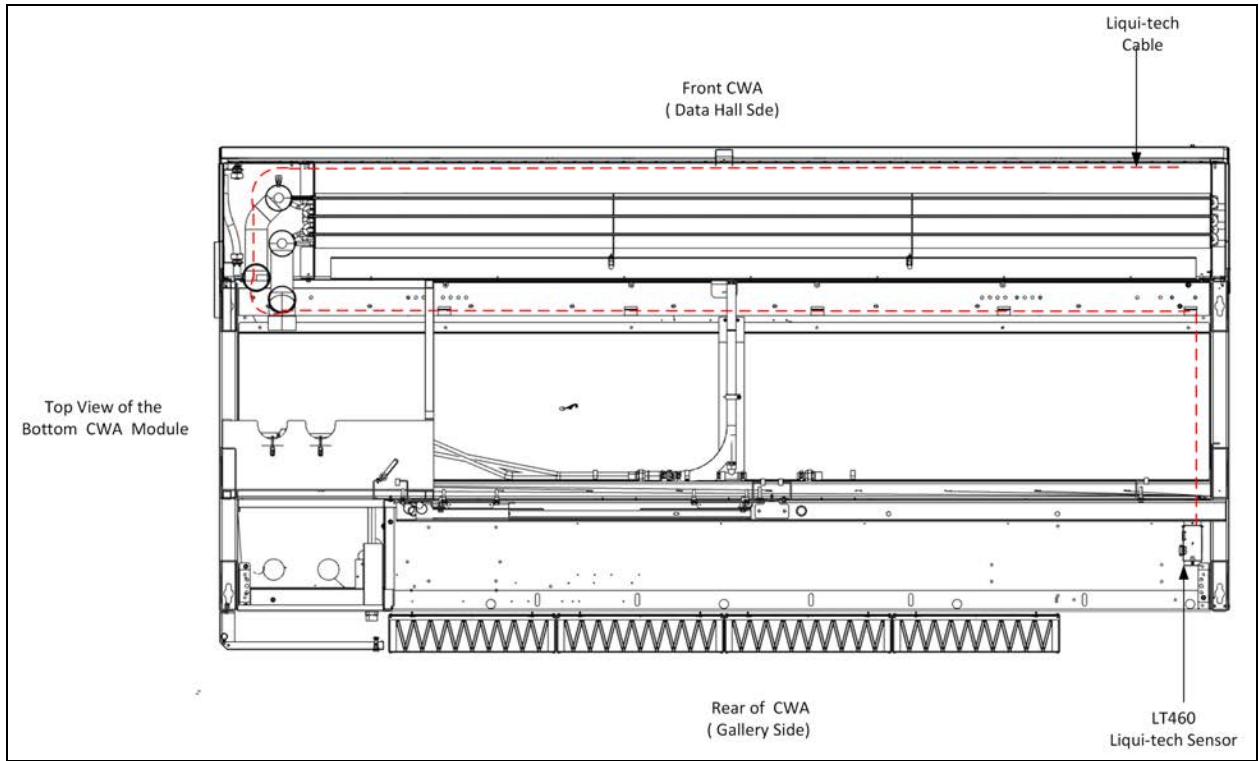
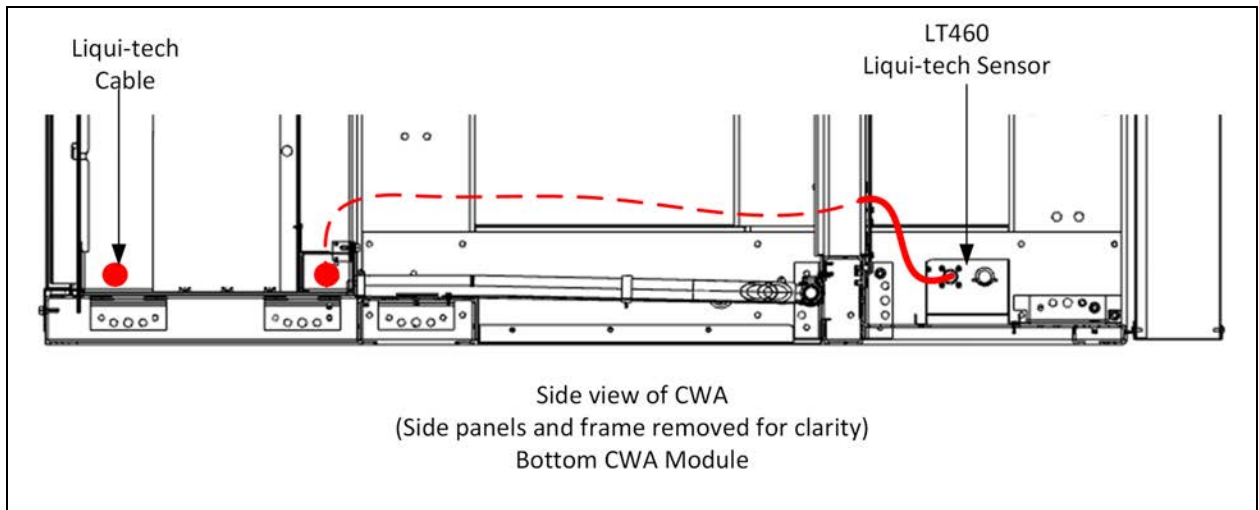

Figure 5.3 Approximate Cable Routing LT460



5.2 Air Temperature Sensor Location (Data Hall Side Only)

There are two data hall side air temperature sensors to measure the temperature of the supply air on each module (top and bottom). See **Figure 5.4** below for locations of each sensor.

Figure 5.4 CWA Air Sensor Location

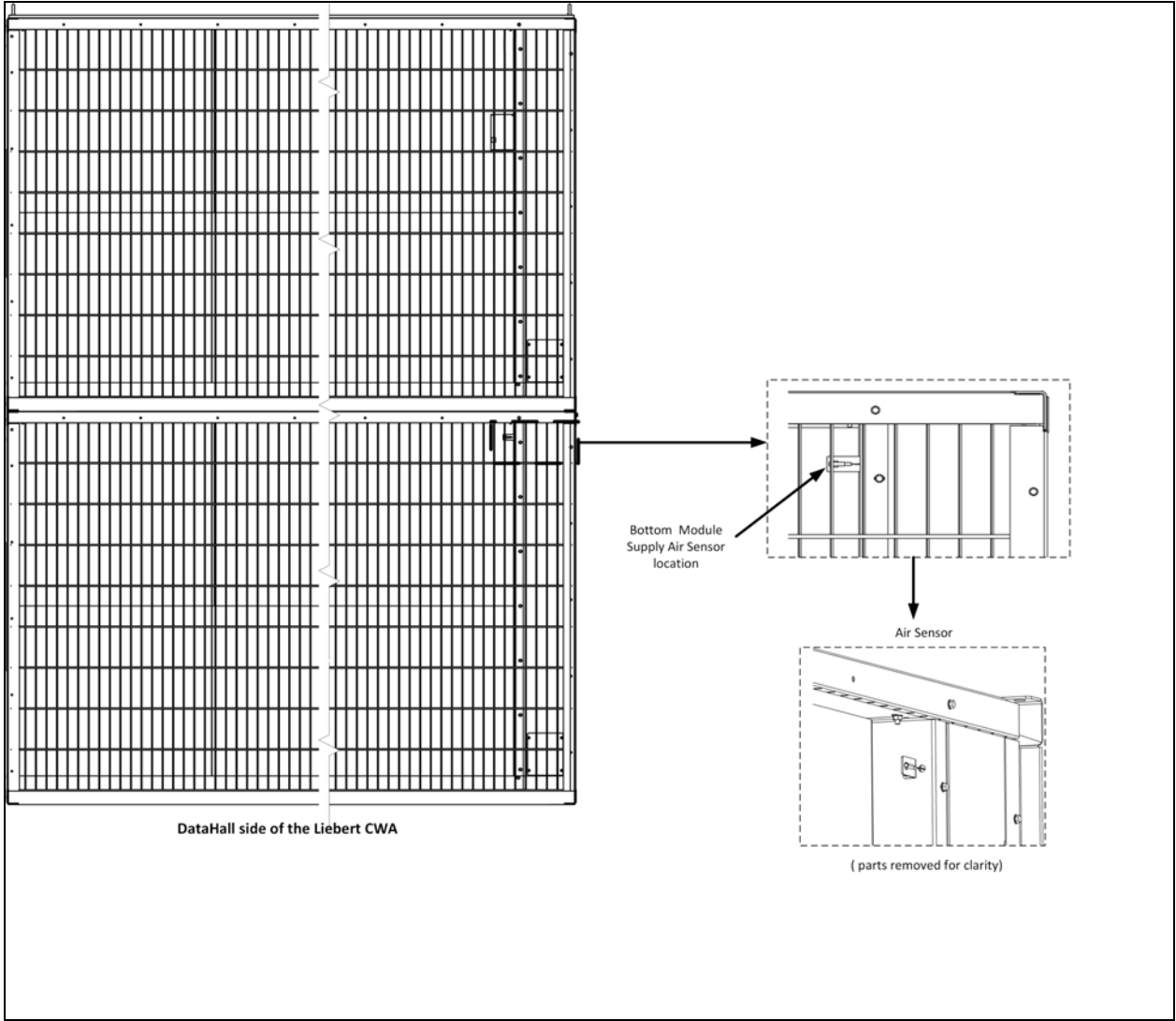

This page intentionally left blank

6 Piping Requirements

All fluid connections to the unit, with the exception of the condensate drain, are sweat copper or optional flanged connections. Factory installed piping brackets must not be removed. Field installed piping must be installed in accordance with local codes and must be properly assembled, supported, isolated and insulated. Avoid piping runs through noise sensitive areas, such as office walls and conference rooms.

Refer to specific text and detailed diagrams in this manual for other unit specific piping requirements.

The pipe connection locations, piping general arrangement and schematics are described in the submittal documents included in the [Submittal Drawings](#) on page 65 .

Relevant documents are referenced below by number and title.

Table 6.1 Piping Connection Drawings

Document Number	Title
DPN005187	Primary Connection Locations with Brazed Customer Connections
DPN005038	Primary Connection Locations with Flanged Customer Connections
DPN005193	Top and Bottom Module Assembly, Internal Condensate Drain Line Connection
DPN005197	Field Gravity Drain Connection

6.1 Drain Fluid Connections

NOTICE

Risk of water leakage. Can cause severe property damage and loss of critical data center equipment.

The Vertiv™ Liebert® CWA requires a water drain connection. Improper installation, application and service practices can result in water leakage from the unit.

Do not locate the unit directly above any equipment that could sustain water damage.

We recommend installing monitored leak detection equipment for the water supply lines and the internal unit water lines.

The following pipe connections are required:

- A drain line from the unit.
- Supply and return water lines.

Table 6.2 Internal Water Volume

Model	Volume
	Gallons (liters)
CWA 4 row	58.42 (221.1)
CWA 6 row	75.83 (287)
CWA 8 row	93.24 (353)

6.1.1 Field Installed, Gravity Drain Line Requirements

NOTICE

Risk of water backing up in the drain line. Leaking and overflowing water can cause equipment and building damage.

Sagging condensate drain lines may inadvertently create an external trap.

A 3/4-in NPT female drain connection is provided on units without an optional condensate pump.

Observe the following requirements when installing and routing the drain line:

- The drain line must be sized for 2 gpm (7.6 l/m) flow.
- The drain line must be located so it will not be exposed to freezing temperatures.
- The drain should be the full size of the drain connection.
- The drain line must slope continuously away from the unit. Pitch drain line toward drain a minimum of 1/8 in. (3 mm) per 1 ft (305 mm) of length.
- The drain line must be rigid enough so that it does not sag between supports which unintentionally creates traps.
- The drain line must comply with all applicable codes.
- We recommend installing monitored, under floor leak detection equipment.

6.2 Chilled Water Loop Piping Guidelines



CAUTION: Risk of improper piping installation. Leak checking, fluid chemistry and fluid maintenance can cause equipment damage and personal injury. Installation and service of this equipment should be done only by qualified personnel who have been specially trained in the installation of air conditioning equipment and who are wearing appropriate, OSHA-approved PPE.

NOTICE

Risk of frozen pipes and corrosion from improper coolant mixture. Can cause water leaks resulting in equipment and building damage.

When the cooling unit or piping may be exposed to freezing temperatures, charge the system with the proper percentage of glycol and water for the coldest design ambient temperature. Automotive antifreeze is unacceptable and must NOT be used in any glycol fluid system. Use only HVAC glycol solution that meets the requirements of recommended industry practices. Do not use galvanized pipe.

NOTICE

Risk of piping system corrosion and freezing fluids. Can cause leaks resulting in equipment and very expensive building damage. Cooling coils and piping systems are at high risk of freezing and premature corrosion. Fluids in these systems must contain the proper antifreeze and inhibitors to prevent freezing and premature coil and piping corrosion. The water of water/glycol solution must be analyzed by a competent local water treatment specialist before start up to establish the inhibitor and antifreeze solution and at regularly scheduled intervals throughout the life of the system to determine the pattern of inhibitor depletion.

The complexity of water/glycol solution condition problems and the variations of required treatment programs make it extremely important to obtain the advice of a competent and experienced water treatment specialist and follow a regularly scheduled coolant fluid system maintenance program.

Water chemistry varies greatly by location, as do the required additives, called inhibitors, that reduce the corrosive effect of the fluids on the piping systems and components. The chemistry of the water used must be considered, because water from some sources may contain corrosive elements that reduce the effectiveness of the inhibited formulation. Sediment deposits prevent the formation of a protective oxide layer on the inside of the coolant system components and piping. The water/coolant fluid must be treated and circulating through the system continuously to prevent the buildup of sediment deposits and/or growth of sulfate reducing bacteria.

Proper inhibitor maintenance must be performed in order to prevent corrosion of the system. Consult glycol manufacturer for testing and maintenance of inhibitors.

Commercial ethylene glycol, when pure, is generally less corrosive to the common metals of construction than water itself. It will, however, assume the corrosivity of the water from which it is prepared and may become increasingly corrosive with use if not properly inhibited.

We recommend installing a monitored fluid detection system that is wired to activate the automatic closure of the field-installed coolant fluid supply and return shutoff valves to reduce the amount of coolant fluid leakage and consequential equipment and building damage. The shutoff valves must be sized to close off against the maximum coolant fluid pressure in case of a catastrophic fluid leak.

NOTICE

Risk of no flow condition. Can cause equipment damage.

Do not leave the water/coolant fluid supply circuit in a no-flow condition. Idle fluid allows the collection of sediment that prevents the formation of a protective oxide layer on the inside of tubes. Keep unit switched On and water/coolant fluid supply circuit system operating continuously.

Refer to the appropriate piping general-arrangement schematics for your system for the recommended, field-installed hardware such as shutoff valves. See **Table 6.1** on page 33 .

- For brazed connection units, use copper piping with a brazing alloy with a minimum temperature of 1350°F (732°C), such as Sil-Fos. Avoid soft solders, such as 50/50 or 95/5. The brazed sleeves are provided and stored behind the filter rack and in front of the fans. See **Table 6.1** on page 33
- The flanged connection is a 4-1/8" flange.
- Follow local piping codes and safety codes.
- Qualified personnel must install and inspect system piping.
- The water/glycol cooled system will operate in conjunction with a cooling tower, city water or drycooler.
- Contact a local water consultant regarding water quality, corrosion protection and freeze-protection requirements.
- Install manual shut off valves at the supply and return line to each unit to permit routine service and emergency isolation of the unit.
- Install a monitored, fluid detection system that is wired to activate the automatic closure of field installed coolant fluid supply and return shut off valves to reduce the amount of coolant fluid leakage and consequential equipment and building damage. The shut off valves must be sized to close off against the maximum coolant fluid system pressure in case of a catastrophic fluid leak.

6.2.1 Flanged Connections

For specifications on the flange used, please refer to [Flange Specifications](#) on page 63 .

Checking Flange Condition

1. Check the condition of the flange faces for scratches, dirt, and scale.
2. Check for corrosion pitting and tool marks.
3. Inspect the gasket seating surfaces.
4. Check the areas on the flange where the nuts will seat. These areas should be flat and free from pitting and excessive wear.
5. Confirm that the flange is corrosion free and undamaged.

Flange Alignment between Vertiv™ Liebert® CWA and Field Supplied Flange

1. Visually examine the flange alignment to ensure that an acceptable fit has been obtained.
2. While aligning flanges, make sure that there are no residual stresses in the joint. The use of heat correction for the alignment of flanges is strictly prohibited.
3. Flange faces should be parallel and aligned.
4. The flange bolt holes should be in line so that bolts will pass freely.

Nuts and Bolts Check

1. Visually examine the nuts, studs, and bolts before installation to ensure that they are free from defects such as corrosion and damaged threads. Nuts or bolts with damaged threads should not be used.
2. Check the length of the stud or bolt to avoid short bolting and excessive threads. Flange bolts shall be furnished in a sufficient length to allow use of bolt tensioning equipment or spades, spaces, drip rings and water valves, and the associated extra gaskets.

3. Visually examine studs and nuts after cleaning to ensure that they are free from burrs. Studs and nuts shall be cleaned using a wire brush to remove any dirt on the threads. Lubricant shall be applied on threads and nuts to flange contact surfaces. Lubricant shall not be used in the gasket and in the gasket seating area.
4. The bolt and nut material grades should be correctly identified before they are used.
5. Bolts and nuts can only be re-used if it is known that they have not been overloaded or have not exceeded their yield point.
6. When assembling the nut on the bolt, the nut identification marking must always point outwards.

Gasket Check

1. Do not use sealing compound, grease, or other paste or adhesive on the gasket or flange faces.
2. Do not force the gasket into the gasket seat between the mating flange faces during insertion.
 - a. Once the gasket is seated, bring the mating flanges together carefully without shaking the gasket off the seat.
 - b. Then install all studs and run up all nuts hand-tight.
3. Visually examine gaskets before installation to ensure that they are free from defects.
4. Color coding shall be maintained per the rate and type of gasket provided by the manufacturer.
5. Clean the gasket seating by using a wire brush.
6. Make sure the material is as specified. Look for any possible defects or damage in the gasket such as folds or creases.
7. Soft material gaskets should be replaced with new ones whenever an opened joint is to be closed again.
8. The full face flange gasket shall only be used once.

Flange Bolt Torque Sequence

Follow industry standards when assembling torque bolts and nuts in a criss-cross sequencing using a minimum of three torquing passes.

After the three basic passes are completed, repeat criss-cross sequence until no further rotation of the nut is observed.

Field flange connection to the Vertiv™ Liebert® CWA unit must be installed in accordance with local codes and best industry practice.

6.2.2 Leak Checking for Unit and Field Installed Piping

The fluid systems in the Vertiv™ Liebert® CWA are factory checked for leaks and may be shipped with holding charge. At installation, check all fluid circuits for leaks.

NOTE: We recommend isolating the unit with field-installed shutoff valves during leak checking of field-installed piping. When the units are included in a leak test, use of fluid for pressure testing is recommended. When pressurized gas is used for leak testing the unit, the maximum recommended pressure is 30 psig (207 kPa) and tightness of the unit should be verified by pressure decay over time, (<2 psig/hour [13.8 kPa/hour]) or sensing a tracer gas with suitable instrumentation. Dry seals in fluid valves and pumps may not hold a high gas pressure.

This page intentionally left blank

7 Checklist for Completed Installation

7.1 Moving and Placing Equipment

1. Unpack and check received material.
2. Assemble top and bottom module together.
3. Ensure proper vertical alignment between top and bottom modules. See [Final Installation](#) on page 24 .
4. Proper clearance for service access has been maintained around the equipment.
5. Equipment is level and mounting fasteners are tight.

7.2 Electrical Installation Checks

1. Supply voltage and phase matches equipment nameplate.
2. Power wiring connections completed to the disconnect switch and unit.
3. Power line circuit breakers or fuses have proper ratings for equipment installed.
4. All internal and external high and low voltage wiring connections are tight.
5. Confirm that unit is properly grounded to an earth ground.
6. Control transformer setting matches incoming power.
7. Electrical service conforms to national and local codes.
8. Check blowers for proper rotation.

7.3 Piping Installation Checks

1. Piping completed to coolant loop.
2. Piping has been leak checked.
3. Piping has been flushed to clear debris, pipe dope, and contaminants.
4. Piping is properly sized.
5. Check piping inside and outside of equipment for proper support and adequate spacing to prevent rub through.
6. Ensure that factory clamps have been reinstalled.
7. Internal drain line is disconnected and is not obstructed.
8. External drain line is pitched per local code and is connected to floor drain.

7.4 Other Installation Checks

1. Filters installed.
2. Check fasteners that secure motors—some may have become loose during shipment.
3. All fans are free of debris.

This page intentionally left blank

8 Initial Start Up Checks and Commissioning Procedure For Warranty Inspection



WARNING! Arc flash and electric shock hazard. Open all local and remote electric power supply disconnect switches, verify with a voltmeter that power is Off and wear appropriate, OSHA-approved personal protective equipment (PPE) per NFPA 70E before working within the electric control enclosure. Failure to comply can cause serious injury or death. Customer must provide earth ground to unit, per NEC, CEC and local codes, as applicable. Before proceeding with installation, read all instructions, verify that all the parts are included and check the nameplate to be sure the voltage matches available utility power. The Vertiv™ Liebert® iCOM™ controller does not isolate power from the unit, even in the Unit Off mode. Some internal components require and receive power even during the Unit Off mode of the controller. The only way to ensure that there is NO voltage inside the unit is to install and open a remote disconnect switch. Refer to unit electrical schematic. Follow all local codes.



WARNING! Risk of electric shock. Can cause equipment damage, injury or death. Open all local and remote electric power supply disconnect switches and verify with a voltmeter that power is off before working within any electric connection enclosures. Installation, service, and maintenance work must be performed only by properly trained and qualified personnel and in accordance with applicable regulations and manufacturers' specifications. Opening or removing the covers to any equipment may expose personnel to lethal voltages within the unit even when it is apparently not operating and the input wiring is disconnected from the electrical source.



WARNING! Risk of improper wiring, piping, moving, lifting and handling. Can cause equipment damage, serious injury or death. Installation and service of this equipment should be done only by qualified personnel who have been specially trained in the installation of air conditioning equipment and who are wearing appropriate, OSHA-approved PPE.

- Confirm that all items on [Checklist for Completed Installation](#) on page 39 have been done.
- Locate the Vertiv™ Liebert® CWA Warranty Inspection Check Sheet in the unit's electric panel.
- Complete Vertiv™ Liebert® CWA Warranty Inspection Check Sheet during start up.
- Forward the completed Vertiv™ Liebert® CWA Warranty Inspection Check Sheet to your local sales office. **This information must be completed and forwarded to validate warranty.**
- Contact your local sales representative or technical support if you have any questions or problems during unit start up and commissioning. Visit <https://www.Vertiv.com/en-us/support/> or call 1-800-222-5877 for contacts.

This page intentionally left blank

9 Maintenance



WARNING! Arc flash and electric shock hazard. Open all local and remote electric power supply disconnect switches, verify with a voltmeter that power is Off and wear appropriate, OSHA-approved personal protective equipment (PPE) per NFPA 70E before working within the electric control enclosure. Failure to comply can cause serious injury or death. Customer must provide earth ground to unit, per NEC, CEC and local codes, as applicable. Before proceeding with installation, read all instructions, verify that all the parts are included and check the nameplate to be sure the voltage matches available utility power. The Vertiv™ Liebert® iCOM™ controller does not isolate power from the unit, even in the Unit Off mode. Some internal components require and receive power even during the Unit Off mode of the controller. The only way to ensure that there is NO voltage inside the unit is to install and open a remote disconnect switch. Refer to unit electrical schematic. Follow all local codes.



WARNING! Risk of electric shock. Can cause equipment damage, injury or death. Open all local and remote electric power supply disconnect switches and verify with a voltmeter that power is off before working within any electric connection enclosures. Installation, service, and maintenance work must be performed only by properly trained and qualified personnel and in accordance with applicable regulations and manufacturers' specifications. Opening or removing the covers to any equipment may expose personnel to lethal voltages within the unit even when it is apparently not operating and the input wiring is disconnected from the electrical source.



WARNING! Risk of improper wiring, piping, moving, lifting and handling. Can cause equipment damage, serious injury or death. Installation and service of this equipment should be done only by qualified personnel who have been specially trained in the installation of air conditioning equipment and who are wearing appropriate, OSHA-approved PPE.



WARNING! Risk of electric shock. Can cause serious injury or death. The Vertiv™ Liebert® iCOM™ microprocessor does not isolate power from the unit, even in the "Unit Off" mode. Some internal components require and receive power even during the "unit off" mode of the Vertiv™ Liebert® iCOM™ control. Open all local and remote electric power disconnect switches and verify with a voltmeter that power is Off before working on any component of the system.

The Vertiv™ Liebert® CWA is a facility heat removal system that consists of a top and bottom module that is assembled in the field.

- Good maintenance practices are essential to minimizing operation costs and maximizing product life.
- Read and follow monthly and semi-annual maintenance schedules included in this manual. These MINIMUM maintenance intervals may need to be more frequent based on site specific conditions.
- See the Vertiv™ Liebert® iCOM™ user manual, SL-31075, available at www.Vertiv.com for instructions on using the controller to predict some service maintenance intervals.
- We recommend the use of trained and authorized service personnel, extended service contracts, and factory-specified replacement parts. Contact your Vertiv sales representative.

9.1 Filters

NOTICE

Risk of improper filter installation. Can cause filter collapse and air flow reduction.

To maximize the performance and reliability of the equipment, use only Vertiv filters. Contact your Vertiv representative to order replacement filters.

Verify that filters are installed and positioned so that air flow direction marked on the filter is the same direction as unit air flow.

Table 9.1 Filter Quantity and Type

Unit Size	Filter Type	Quantity
CA60—Bottom (Base) Module	MERV 8	15
CA60—Top Module	MERV 8	18

9.1.1 Replacing the Filters



WARNING! Risk of contact with high speed rotating fan blades. Can cause serious injury or death. Open all local and remote electric power supply disconnect switches, verify with a voltmeter that power is off, and verify that all fan blades have stopped rotating before working in the unit cabinet or on the fan assembly. If control voltage is applied, the fan motor can restart without warning after a power failure. Do not operate the unit with any or all cabinet panels removed.

1. The filters are accessed through the gallery side of the module. See **Figure 9.1** on the facing page .
2. Remove and install the filters up and down in the columns. There are three filters in each column. See Submittal DPN005164.

Figure 9.1 Filter Location, Gallery Side of Modules

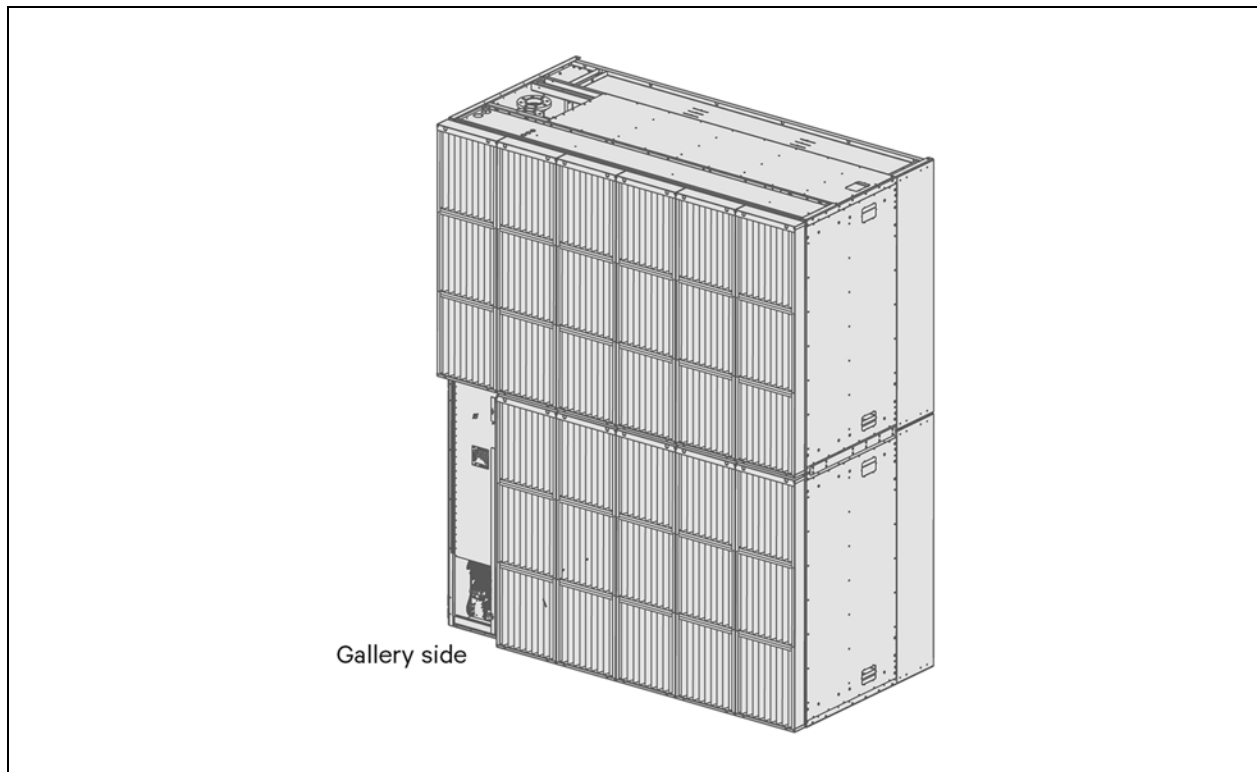

9.2 Fan Maintenance

9.2.1 Fan Assembly Troubleshooting

Any safety hazards stemming from the device must be re-evaluated once it is installed in the end device.

Do not make any modifications, additions or conversions to the fan assembly without the approval of Vertiv.



WARNING! Risk of electric shock. Can cause serious injury or death. Open all local and remote electric power supply disconnect switches and verify with a voltmeter that power is off before opening the fan motor electric-connection enclosure. Fan motor controls can maintain an electric charge for 10 minutes after power is disconnected. Wait 10 minutes after power is verified as off before working within the electric control connection enclosures. Use only fully-trained and qualified HVAC technicians to perform maintenance on the fans.



WARNING! Risk of contact with high speed rotating fan blades. Can cause serious injury or death. Open all local and remote electric power supply disconnect switches, verify with a voltmeter that power is off, and verify that all fan blades have stopped rotating before working in the unit cabinet or on the fan assembly. If control voltage is applied, the fan motor can restart without warning after a power failure. Do not operate the unit with any or all cabinet panels removed.



CAUTION: Risk of exposure to harmful noise levels. Can cause hearing injury or loss. Depending on the installation and operating conditions, a sound pressure level greater than 70 dB(A) may arise. Take appropriate technical safety measures. Operating personnel must wear appropriate, OSHA-approved PPE and observe all appropriate hearing-protection safety requirements.



CAUTION: Risk of contact with hot surfaces. Can cause injury. The fan motor, and some electrical components are extremely hot during unit operation. Allow sufficient time for them to cool to a touch-safe temperature before working within the unit cabinet. Use extreme caution and wear appropriate, OSHA-approved PPE when working on or near hot components.

Risk of improper power supply connection. Can cause equipment damage and loss of warranty coverage.

Prior to connecting any equipment to a main or alternate power source (for example: backup generator systems) for start up, commissioning, testing, or normal operation, ensure that these sources are correctly adjusted to the nameplate voltage and frequency of all equipment to be connected. In general, power source voltages should be stabilized and regulated to within $\pm 10\%$ of the load nameplate nominal voltage. Also, ensure that no three-phase sources are single phased at any time.

NOTE: Do not assume that the fan blades will not start to spin. If the motor is in a fault condition, it will safely shut down. Once the fault condition is cleared, there are certain conditions in which the motor will automatically resume operation.

9.2.2 Fan Impellers

Fan impellers should be periodically inspected and any debris removed. Check to ensure that the impellers can rotate freely.

Consult the factory for fan assembly maintenance and removal instructions.

9.2.3 Backdraft Barrier Kits

Backdraft barrier plates can be used to block airflow when fans are not in operation. If kit is required, contact your Vertiv sales rep. See submittal drawings for kit details.

Figure 9.2 Standard Axial Fan Backdraft Barrier Plate Kit

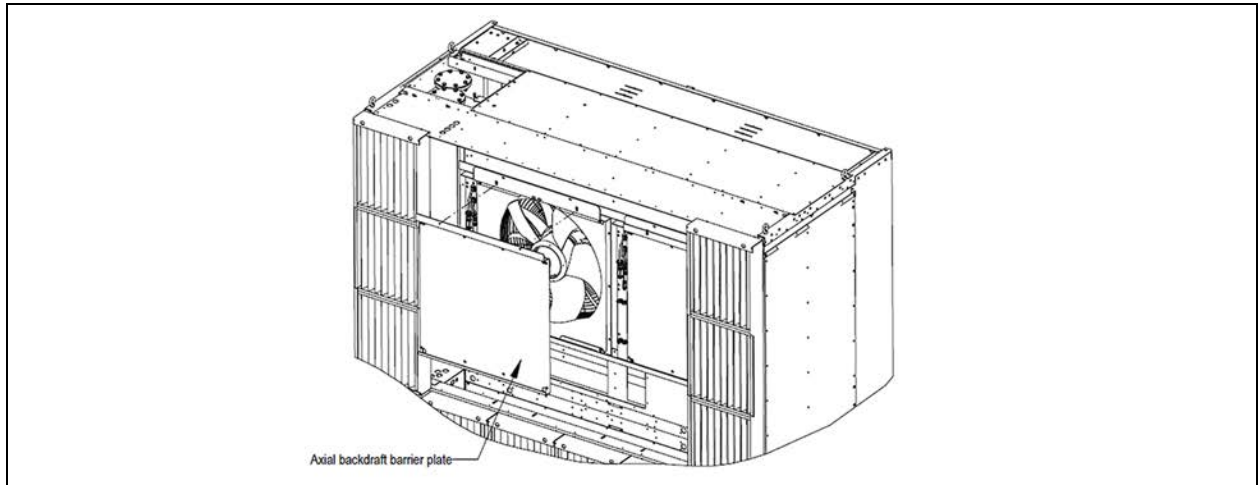

Figure 9.3 High Airflow, High Efficiency Fan Backdraft Barrier Plate Kit

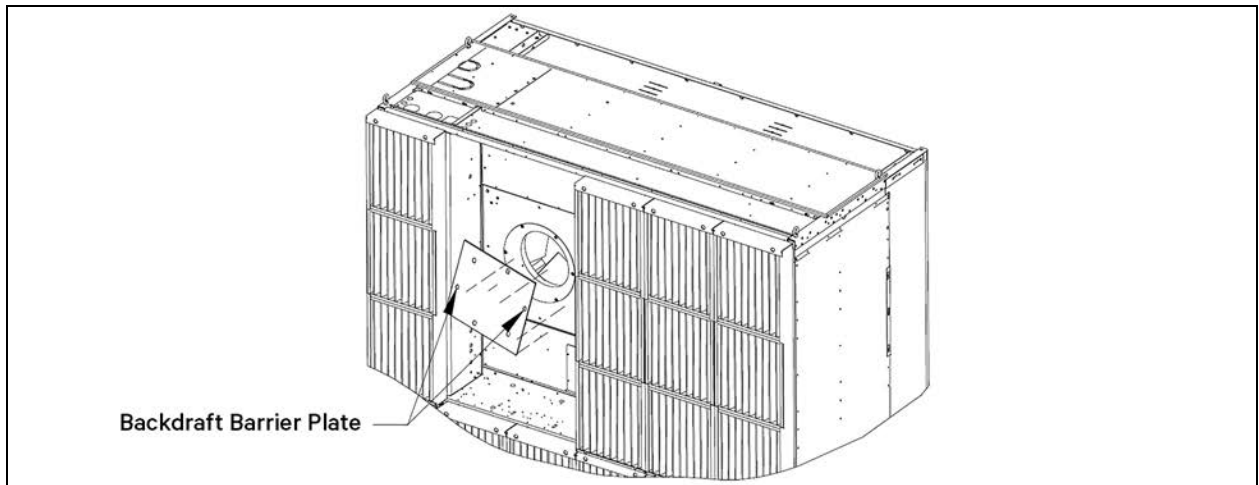

Table 9.2 Backdraft Barrier Plate Drawings

Document Number	Fan Type
10020374	Backdraft Barrier Plate Kit - Standard Axial Fan
10013279	Backdraft Barrier Plate Kit - High Airflow, High Efficiency Fan

9.2.4 Removing Fan Assembly

Do not attempt to remove the fan assemblies without first contacting Vertiv Technical Support at 1-800-543-2778.



WARNING! Risk of very heavy 125-lb (56.7-kg) fan modules dropping downward suddenly. Can cause injury or death. Support fan modules before removing mounting hardware. Use caution to keep body parts out of the fan modules pathway during repositioning. Only properly trained and qualified personnel should work on this equipment.



CAUTION: Risk of improper handling of heavy and lengthy parts. Can cause personal injury and equipment damage. Follow relevant OSHA lifting recommendations and consider using a two-person lift for safe and comfortable removal and installation of cabinet panels. Only properly trained and qualified personnel wearing appropriate, OSHA-approved PPE should attempt to remove or install cabinet panels or components.

NOTE: We recommend using a duct lift or scissor lift when removing or installing the fan assemblies into the unit.

Equipment recommended to replace or install the new fans:

- Overhead winch or crane
 - Duct lift
 - Lift chains with hooks
 - Scissor lift
1. Turn unit off at the I/O switch, then turn disconnect off. Be sure proper lockout/tagout procedures are observed.
 2. Remove filter rack section. (See DPN005164 included in [Submittal Drawings](#) on page 65, for details on filter rack removal.)
 3. Locate and remove the high and low voltage wiring from the fan. Reference the electrical schematic.

NOTE: Do not remove fan assembly using ladders. The fan assembly is removed using scissor lift or scaffolding.

4. How to uninstall a Liebert® CWA fan module.
 - a. Loosen all the fasteners attaching the fan assembly to the unit, see **Figure 9.4** on the facing page.

Figure 9.4 Loosening Fasteners from the Fan Assembly

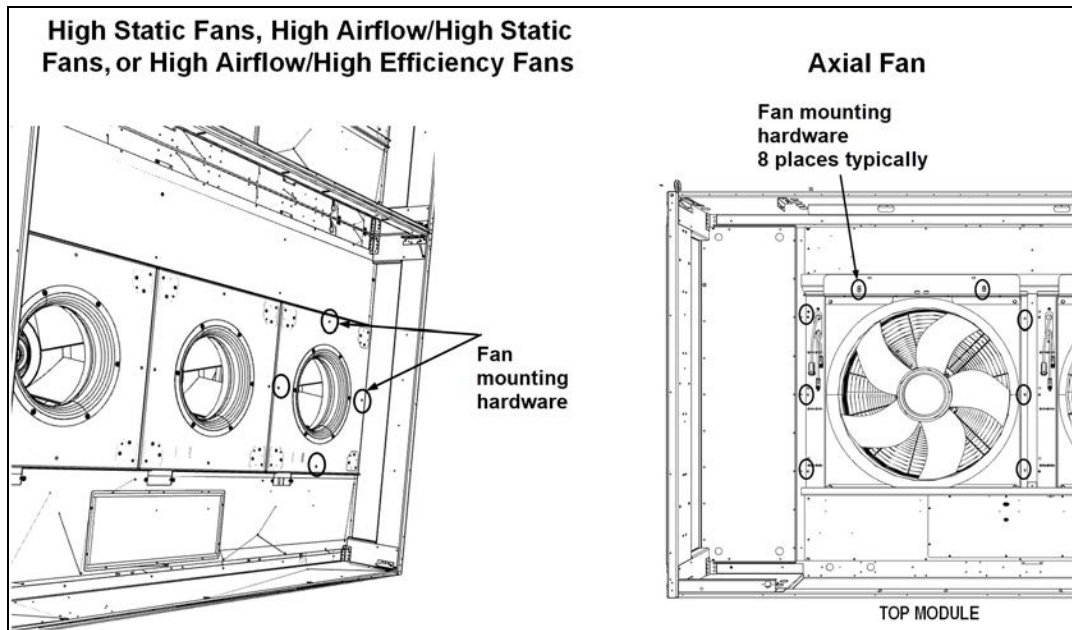

- b. Disconnect all power and communication connectors to the fan module, see **Figure 9.5** below.

Figure 9.5 Power and Communication Connectors

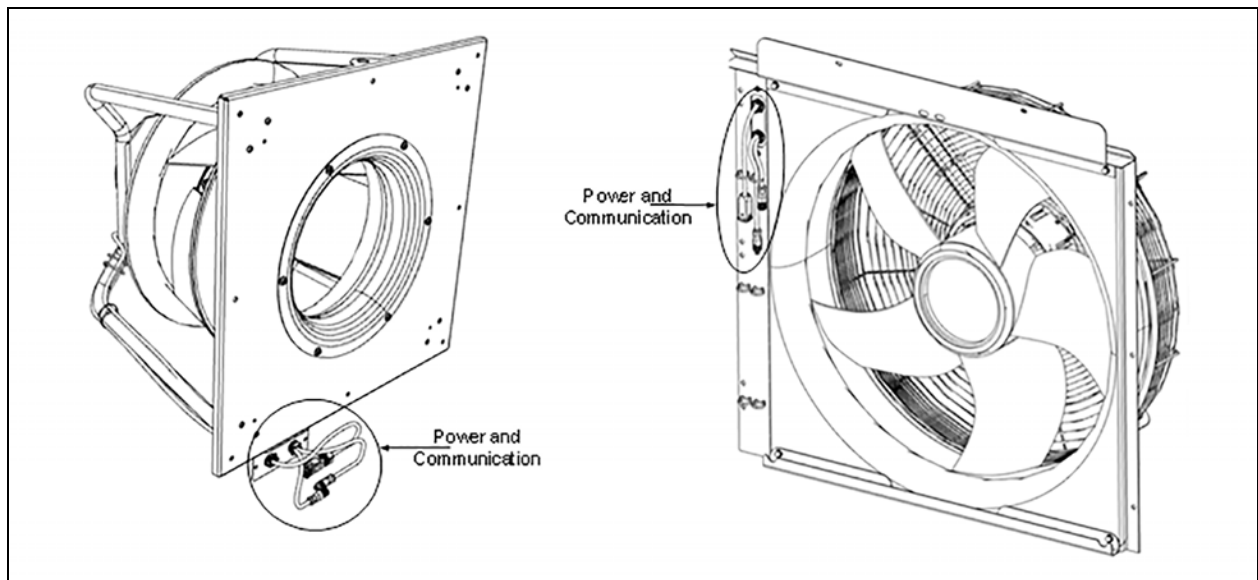

- c. Take care not to damage the damper gasket behind the fan module.
5. Before you attempt to remove the fan module, locate the fan hoist mounting locations for the upper and lower module, see layout on **Figure 9.6** on the next page. Also please reference **Figure 9.4** above and **Figure 9.5** above.

Figure 9.6 Lift Point for Top and Bottom Modules

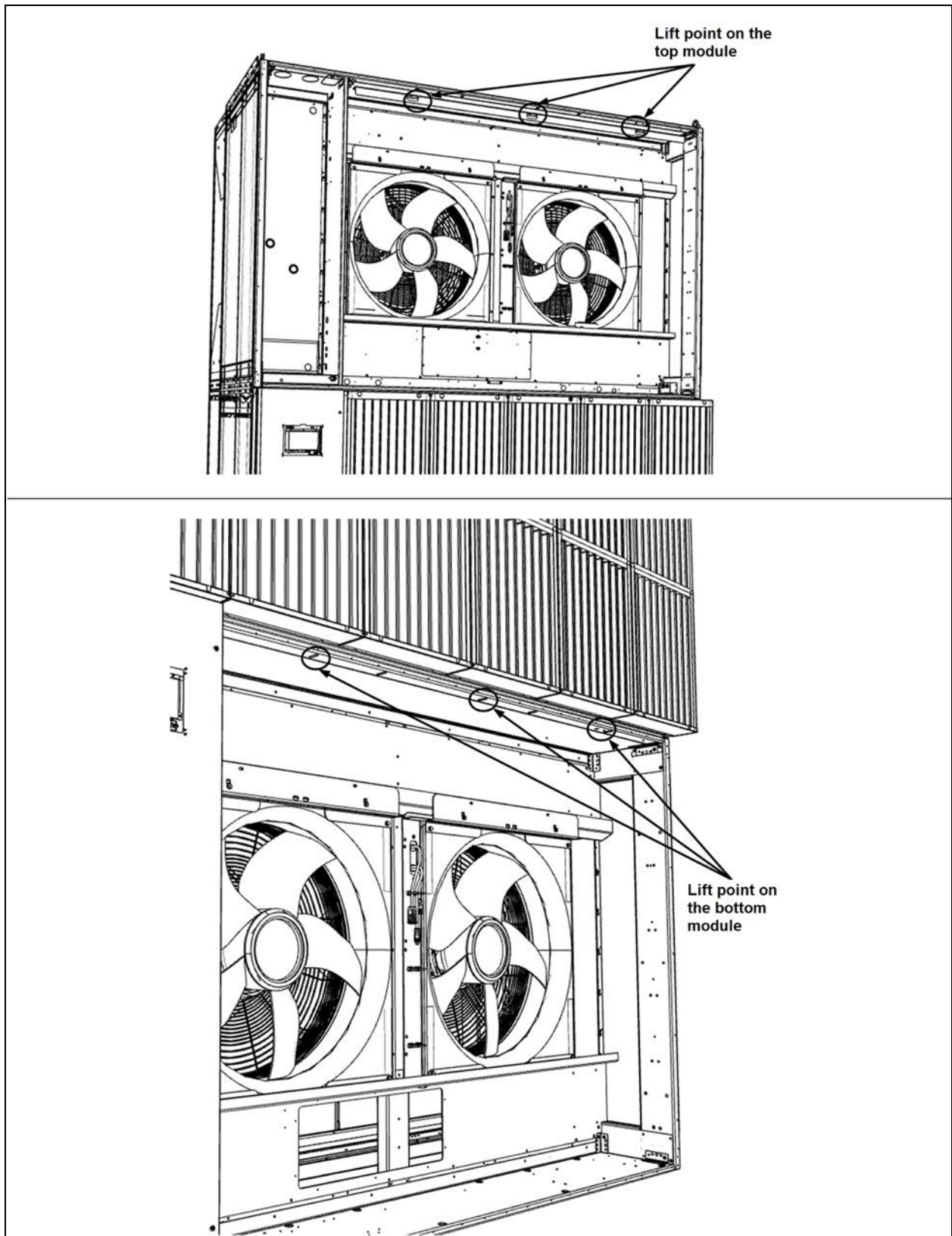

6. Attach the lift chains or straps to the hoist locations and to the fan module.
7. Removal steps for a unit equipped with either high static or composite fans:
 - a. While the supporting fan, tilt the fan out from the mounting point to reach the lift points.
 - b. Each fan sub-assembly has three lifting points for lifting the fan into or out of the frame.
 - c. Insert a strap or hooks into the lifting points to remove the fan, see **Figure 9.7** below .

Figure 9.7 Using Lifting Points to Remove High Static Fans, High Airflow/High Static Fans, or High Airflow/High Efficiency Fans

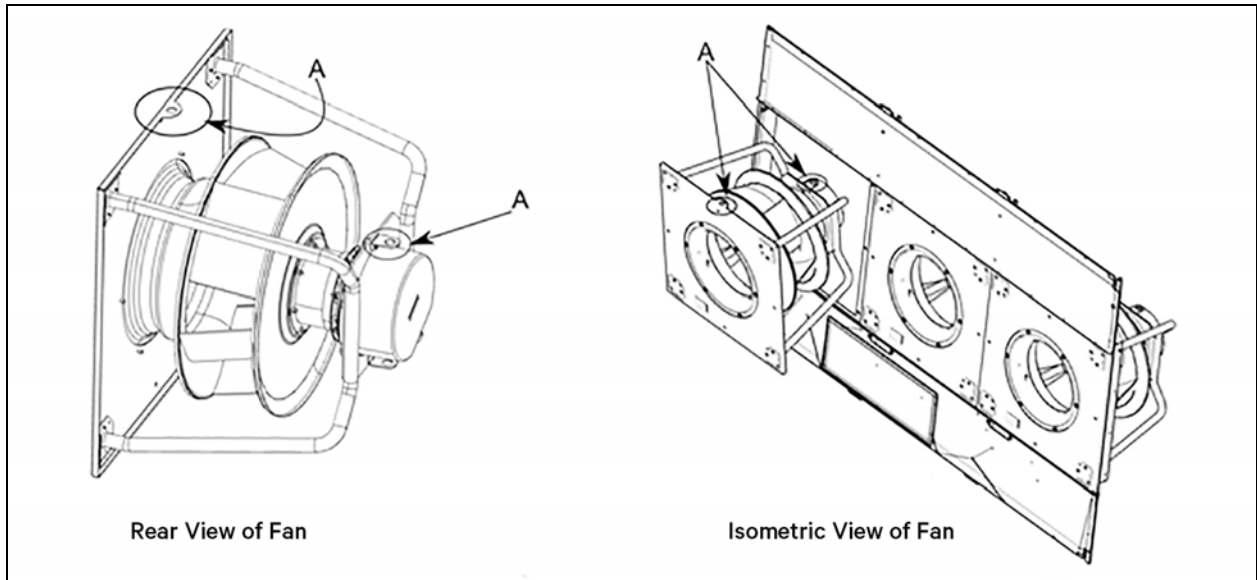

Item	Description
A	Lifting Points

8. Removal steps for unit equipped with an axial fan:
 - a. While supporting the fan, tilt the fan out from the mounting point to reach the lift points.
 - b. Each fan sub-assembly has two lifting points for lifting the fan into or out of the frame.
 - c. Insert a strap or hooks into the lifting points to remove the fan, see **Figure 9.8** on the next page .

Figure 9.8 Axial Fan Lift Points

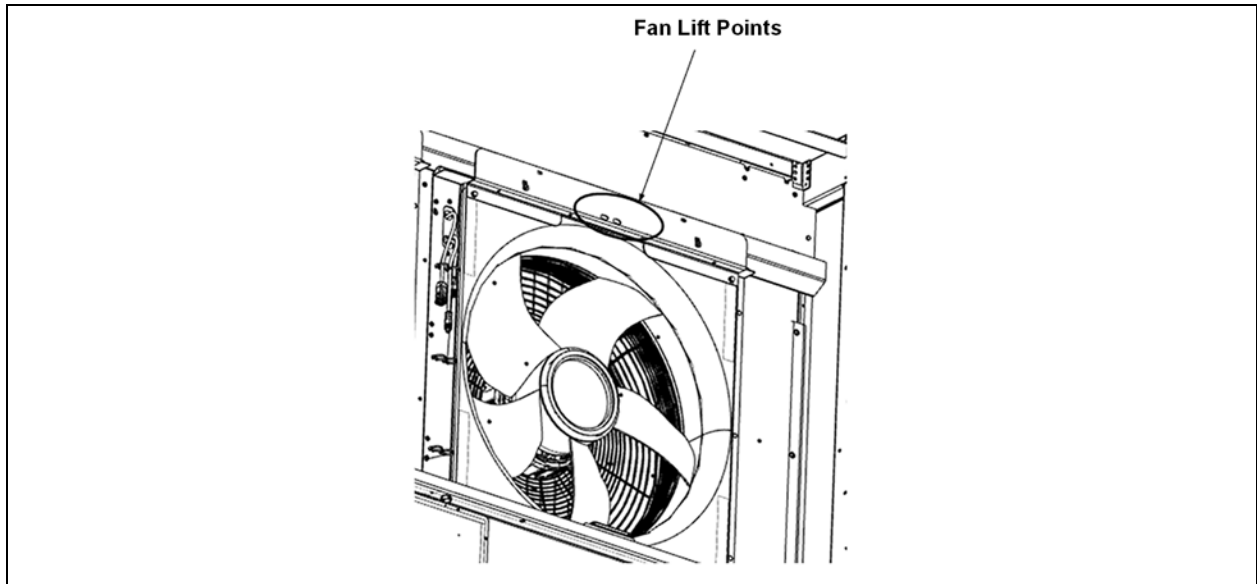

Reinstalling Fan Assembly

9. Lift the new fan line up and install the top two bolts into the assembly.
10. Line up and install the bottom four bolts on the fan assembly to the unit.
11. Locate and connect the high and low voltage wiring from the fan to the unit.
12. Remove lockout/tagout and energize unit.
13. Complete Modbus addressing setup at the Vertiv™ Liebert® iCOM™ display for the replaced fan.
14. In the iCOM control, navigate to Service Menu > Auxiliary Device Setup > Modbus Devices > Modbus Fan menu.
 - a. Change the address of the replaced fan to 1 and enable the fans to operate using manual mode. This will enable high voltage power to the fans.
 - b. iCOM will communicate with the replaced fan at address 1. iCOM will automatically change the Modbus address to the correct value based on replaced fan location.

Figure 9.9 Liebert Clearance Dimensional Data

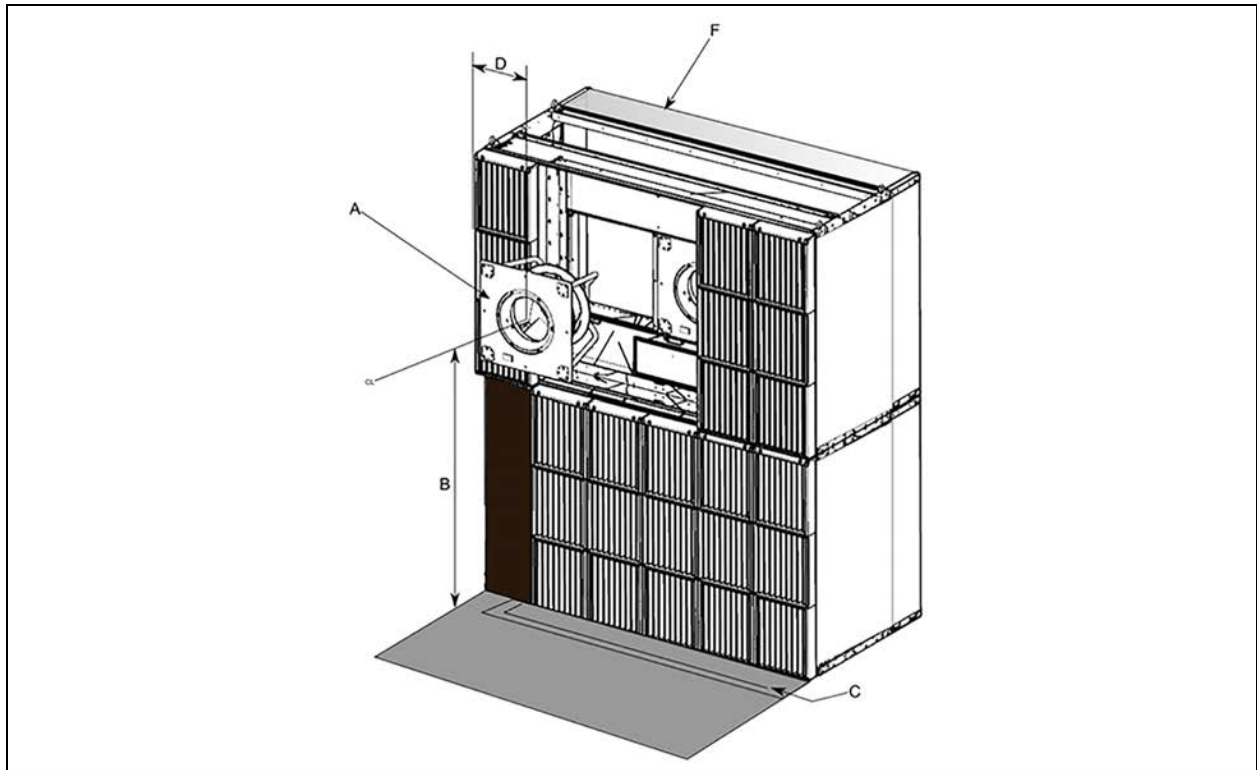
**NOTE:**

A = Fan removal on gallery side.

B = Varies depending on the fan type and fan location, measured from the center line of the fan to the floor

C = Gravity drain line running in front of the Liebert CWA

D = Varies depending on the fan type and fan location

F = Chilled water coil, data hall side

9.3 Condensate Drain System Maintenance

9.3.1 Condensate Drain

Check for and clear obstructions in tubing during routine maintenance.

9.3.2 Condensate Pump



WARNING! Risk of electric shock. Can cause injury or death. Open all local and remote electric power supply disconnect switches and verify that power is Off with a voltmeter before working within the condensate pump electrical connection enclosure. The Vertiv™ Liebert® iCOM™ does not isolate power from the unit, even in the “Unit Off” mode. Some internal components require and receive power even during the “Unit Off” mode of the Vertiv™ Liebert® iCOM.

To maintain the condensate pump:

1. Disconnect power to the unit using the disconnect switch.
2. Check for and clear obstructions in gravity lines leading to the condensate pump.
3. Remove the sump, clean with a stiff nylon brush and flush with water.
4. Inspect and clear clogs in the discharge check valve and float mechanism.
5. Reassemble and check for leaks.

9.3.3 Coil Drain Plug

If the coil needs to be drained or removed from site, please use the standard practice to decommission a unit.

NOTE: Dimensional information regarding plug location is on DPN005187 Primary Connection Locations with Brazed Connections and DPN005038 Primary Connection Locations, with Flanged Customer Connections.

Figure 9.10 Coil Drain Plug Detail

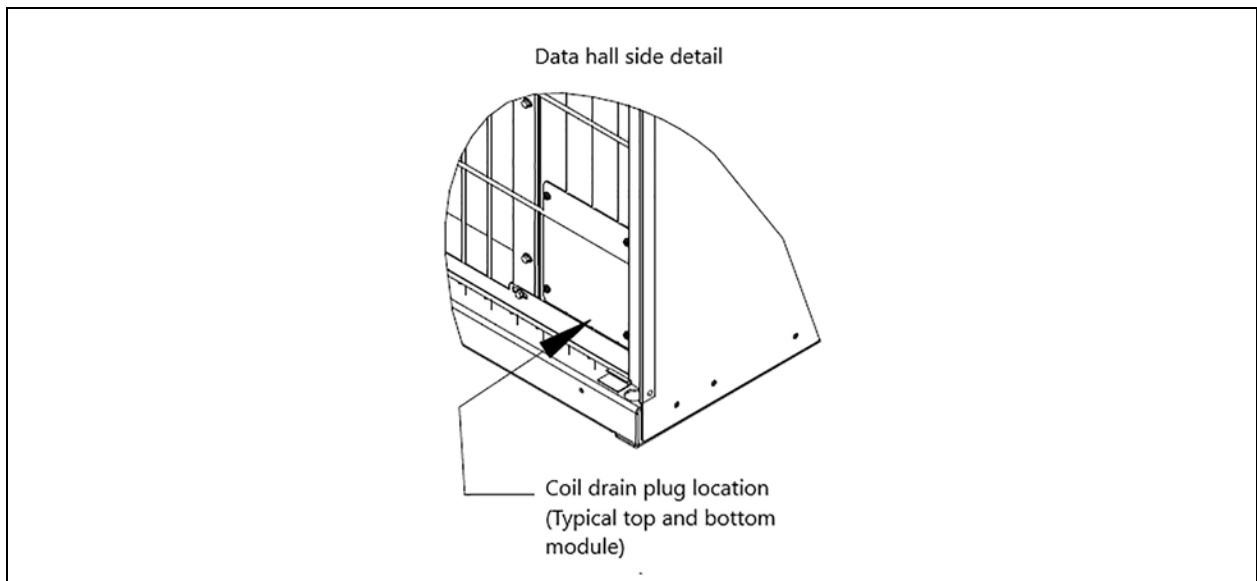

9.3.4 Facility Fluid and Piping Maintenance

Maintaining the system fluid quality is required throughout the life of the system. Fluid and piping system maintenance schedules must be established and performed. A coolant fluid maintenance program must be established that will evaluate fluid chemistry and apply necessary treatment. The complexity of water/glycol solution condition problems and the variations of required treatment programs make it extremely important to obtain the advice of a competent and experienced water-treatment specialist and follow a regularly scheduled coolant fluid system maintenance program.

Perform periodic inspections of the facility and the unit coil and/or heat exchanger and coolant fluid piping system for leaks and visible damage.

9.3.5 Glycol Solution Maintenance

It is difficult to establish a specific schedule of inhibitor maintenance because the rate of inhibitor depletion depends upon local water conditions. Analysis of water samples at the time of installation and through a maintenance program should help to establish a pattern of depletion. A visual inspection of the solution and filter residue is often helpful in judging whether active corrosion is occurring. The complexity of water/glycol solution condition problems and the variations of required treatment programs make it extremely important to obtain the advice of a competent and experienced water treatment specialist and follow a regularly scheduled coolant fluid system maintenance program. It is important to note that improper use of water treatment chemicals can cause problems more serious than using none.

Proper inhibitor maintenance must be performed in order to prevent corrosion of the glycol system. Consult the glycol manufacturer for testing and maintenance of inhibitors. Do not mix products from different manufacturers.

This page intentionally left blank

10 Preventive Maintenance Checklist

Source: DPN002952, Rev. 4

Inspection Date	Job Name
Bottom Module Model #	Bottom Module Serial #
Top Module Model #	Top Module Serial #
Room Temperature/Humidity	° % Ambient Temperature

Not all units will have components. To determine your unit's configuration, compare the Indoor Unit # above and the information in [Nomenclature and Components](#) on page 7.

Good maintenance practices are essential to minimizing operation cost and maximizing product life. Read and follow all applicable maintenance checks listed below. At a minimum, these checks should be performed semi-annually. However, maintenance intervals may need to be more frequent based on site-specific conditions. Review the unit user manual for further information on unit operation. We recommend the use of trained and authorized service personnel, extended service contracts, and factory certified replacement parts. Contact your local sales representative for more details.

Check all that apply:

Evaporator/filters

- Check/replace filters.
- Grille area is unrestricted.
- Wipe section clean.
- Coil clean.
- Clean condensate pan.
- Clean trap in condensate drain.
- Check/test filter clog switch operation (if equipped).

Blower Section

- Blower wheels are free of debris.

- Check motor mount.

- Check motor amp draw.

#1	L1	L2	L3
#2	L1	L2	L3
#3	L1	L2	L3
#4	L1	L2	L3
#5	L1	L2	L3
#6	L1	L2	L3

Condensate Pump (if equipped)

- Check for debris in sump.

- Check operation of floats (free movement).

- Check/clean discharge check valve.

Electrical Panel

- Check fuses.

- Check contactors for pitting. Replace if pitted.

- Check/re-torque wire connections.

Controls

- Check/verify control operation (sequence)..

- Check/test change over device(s), if equipped.

- Check/test water detection device(s), if equipped.

- Check/test CAN connection between unit and sensors, if equipped.

- Check for loose electrical connections.

Chilled Water

- Verify proper water maintenance is being performed.

- Check coil and supply/return lines/connections for water/glycol leaks.

- Check/test water detection device(s), if equipped.

Appendices

Appendix A: Technical Support and Contacts

A.1 Technical Support/Service in the United States

Vertiv Group Corporation

24x7 dispatch of technicians for all products.

1-800-543-2378

Liebert® Thermal Management Products

1-800-543-2378

Liebert® Channel Products

1-800-222-5877

Liebert® AC and DC Power Products

1-800-543-2378

A.2 Locations

United States

Vertiv Headquarters

505 N Cleveland Ave

Westerville, OH 43082

Europe

Via Leonardo Da Vinci 8 Zona Industriale Tognana

35028 Piove Di Sacco (PD) Italy

Asia

7/F, Dah Sing Financial Centre

3108 Gloucester Road

Wanchai, Hong Kong

This page intentionally left blank

Appendix B: Flange Specifications

Figure B.1 Flange Detail

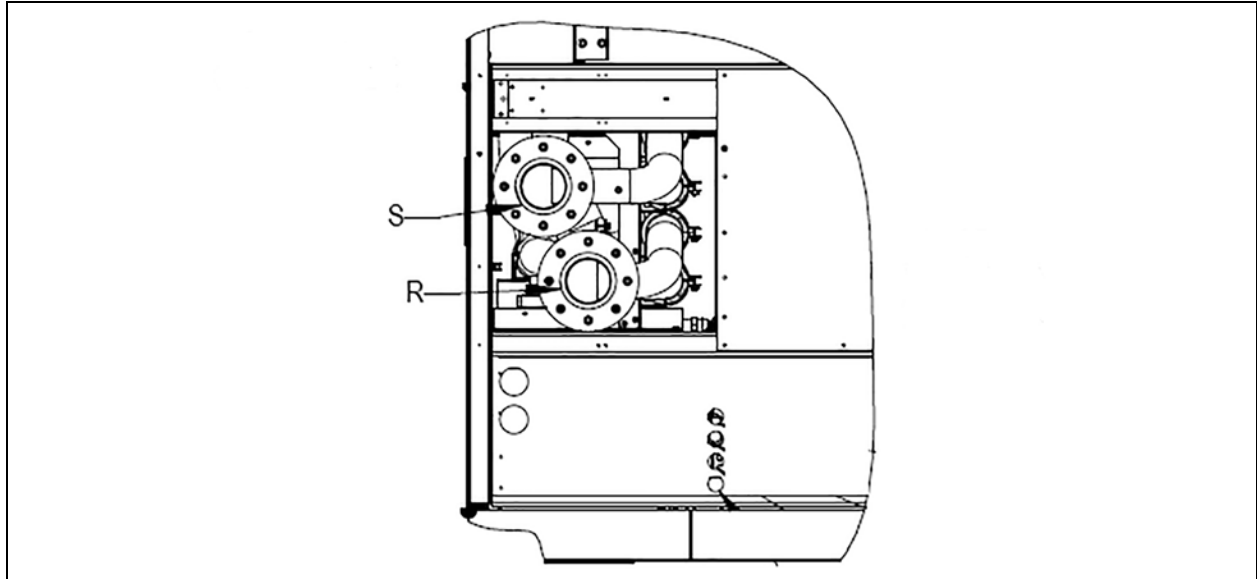

For use with water.

Table B.1 Flange Specifications

Wrot/Steel Flange	
Shape	Straight
Type	2 piece wrot/epoxy floating flange
Class	150 lb.
Connection type	Copper tubing
Connection style	Socket connection X flanged
Flanged connection surface	Raised
Gender	Female
Pipe Size	4
Flange OD	9-in.
For bolt diameter	5/8-in.
Bolt Hole	
Diameter	3/4-in.
Number of	8
Bolt circle diameter	7-1/2-in.
Maximum Pressure	50 psi at 72°F
For Fitting	

Table B.1 Flange Specifications (continued)

Schedule	40
Material	Copper Body: Lead Free Uns C12200
	Steel Base: ASTM A36 Steel Plate
	Steel Base Coating: Dielectric
	Insulating Epoxy Coating
Specifications Met	ASME B26.22
Specifications	Conforms to NSF/ANSI 61 Annex G requirements
	Wrot copper sleeve manufactured to ASME B16.22
	Steel flange holes drilled to ANSI B16.5 specifications
	Temperature range from -66°F to 272°F
Flange Type/Torque Sequence	8 bolt flange/1,5,3,7,2,6,4,8
Torque the flange per standard practice for chilled water applications.	

Table B.2 Full Face Rubber Silicon Flange Gasket

For use with	WaterRef
For pipe size	8 (ANSI Class 150)
Thickness	1/8-in.
Color	Black

Appendix C: Submittal Drawings

Table C.1 Submittal Drawings Contents

Document Number	Title
Component Location Drawings	
DPN005204	Component Location Diagram with Standard Axial Fan
DPN005141	Component Location Diagram with High Airflow/High Efficiency Fan Option
Dimension Planning Drawings	
DPN005036	CWA Cabinet and Anchor Dimensional Data, Bottom and Top Modules
DPN005165	Installation and Service Clearance
DPN005179	Floor Planning for Adjacent Units
DPN005037	Airflow Schematic
Seismic Drawings	
DPN005198	Seismic Application Assumptions and Requirements, IBC 0.75 Sds
DPN003870	Seismic Application Assumptions and Requirements, IBC 2.5 Sds
Filter and Rack Location	
DPN005164	Filter and Filter Rack Removal
Lag Screw Drawings	
DPN005188	Top and Bottom Module Assembly
Electrical Field Connection Drawings	
DPN005143	Electrical Field Connections, Bottom and Top Modules
DPN005195	Electrical Data
DPN005187	Primary Connection Locations with Brazed Connections
DPN005038	Primary Connection Locations with Flanged Customer Connections
Automatic Transfer Switch (ATS)	
DPN005196	Auto Transfer Switch Control Module
THD Transformer	
DPN005208	THD Mitigation CA60 Standard Fan
DPN005211	THD Mitigation CA60 High Airflow High Efficiency Fan
Unit to Unit Networking	
DPN004351	Vertiv™ Liebert® iCOM™ 2 Rack Temperature Sensor Connections
Temperature and Humidity Sensor	
DPN003269	2T Rack Temperature Sensor Connections
DPN000960	Liebert® iCOM Remote Temperature and Humidity Sensor

Table C.1 Submittal Drawings Contents (continued)

Document Number	Title
Piping Connection Drawings	
DPN005187	Primary Connection Locations with Brazed Customer Connections
DPN005038	Primary Connection Locations with Flanged Customer Connections
DPN005193	Top and Bottom Module Assembly, Internal Condensate Drain Line Connection
DPN005197	Field Gravity Drain Connection
Backdraft Barrier Plate Drawings	
10020374	Backdraft Barrier Plate Kit - Standard Axial Fan
10013279	Backdraft Barrier Plate Kit - High Airflow, High Efficiency Fan

COMPONENT LOCATION DIAGRAM with STANDARD AXIAL FAN

Item No.	Description
1	Chilled Water Coil (Typ. 2)
2	Fans (Qty. 4)
3	Air Filters (Typ. 33, Optional)
4	Electric Panel
5	Condensate Drain
6	Condensate Pump (Optional, located behind filters and fans)
7	THD Mitigation Device (Optional)
8	CW Connection location
9	High Voltage Electrical Knockout location
10	Filter Clog Switch (Supplied with optional filters)
11	Liqui-Tect sensor (Optional, located behind filters)
12	Discharge Grill
13	Valve Sight Glasses (Qty. 2)

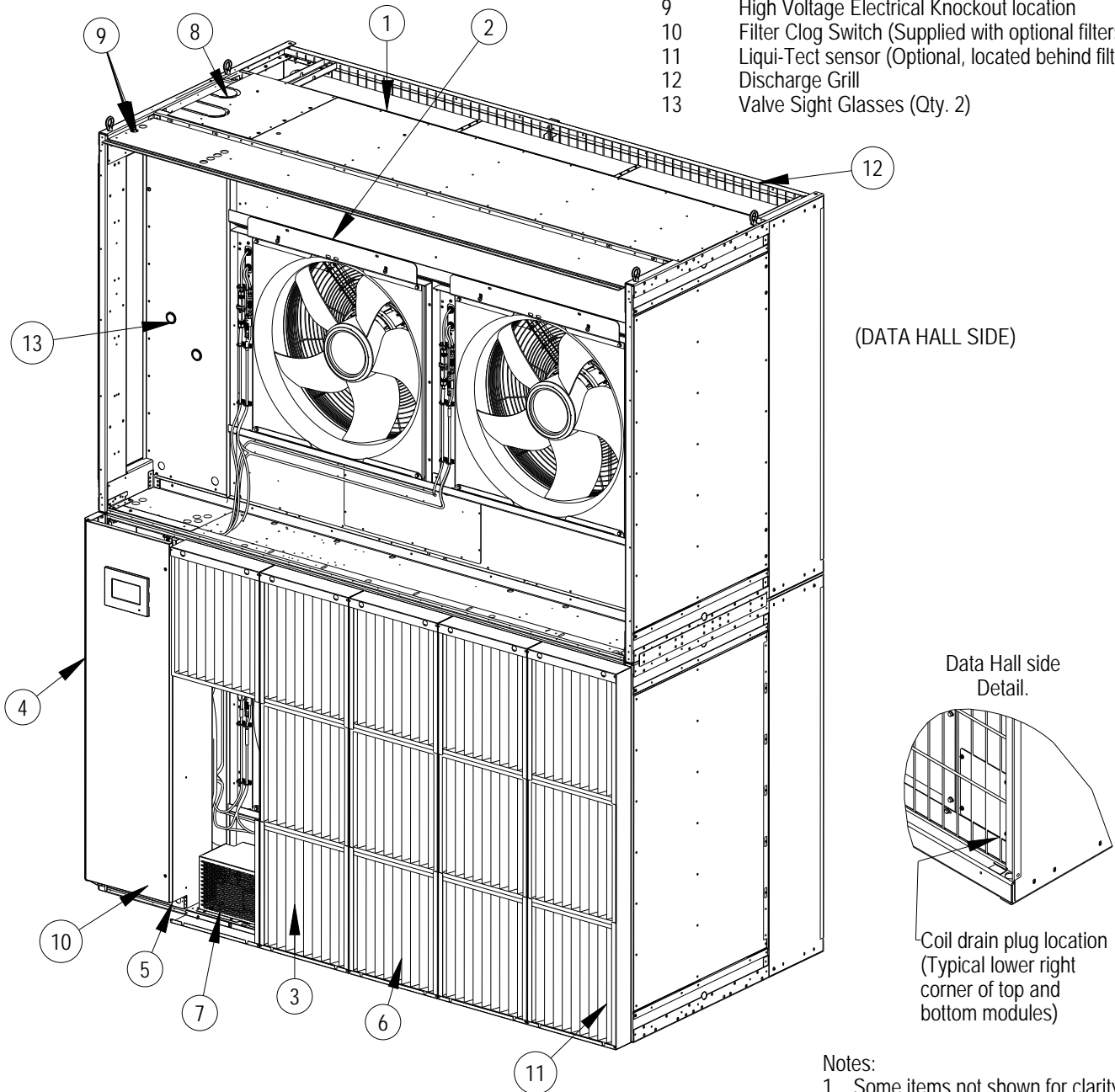

Notes:
1. Some items not shown for clarity.

(GALLERY SIDE)

COMPONENT LOCATION DIAGRAM

with HIGH AIRFLOW / HIGH EFFICIENCY FAN OPTION

Item No.	Description
1	Chilled Water Coil (Typ. 2)
2	Fans (Qty. 6)
3	Air Filters (Typ. 33, Optional)
4	Electric Panel
5	Condensate Drain
6	Condensate Pump (Optional, located behind filters & fans)
7	THD Mitigation Device (Optional)
8	CW Connection location
9	High Voltage Electrical Knockout location
10	Filter Clog Switch (Supplied with optional filters)
11	Liqui-Tect sensor (Optional, located behind filters)
12	Discharge Grill
13	Valve Sight Glass (Qty. 2)

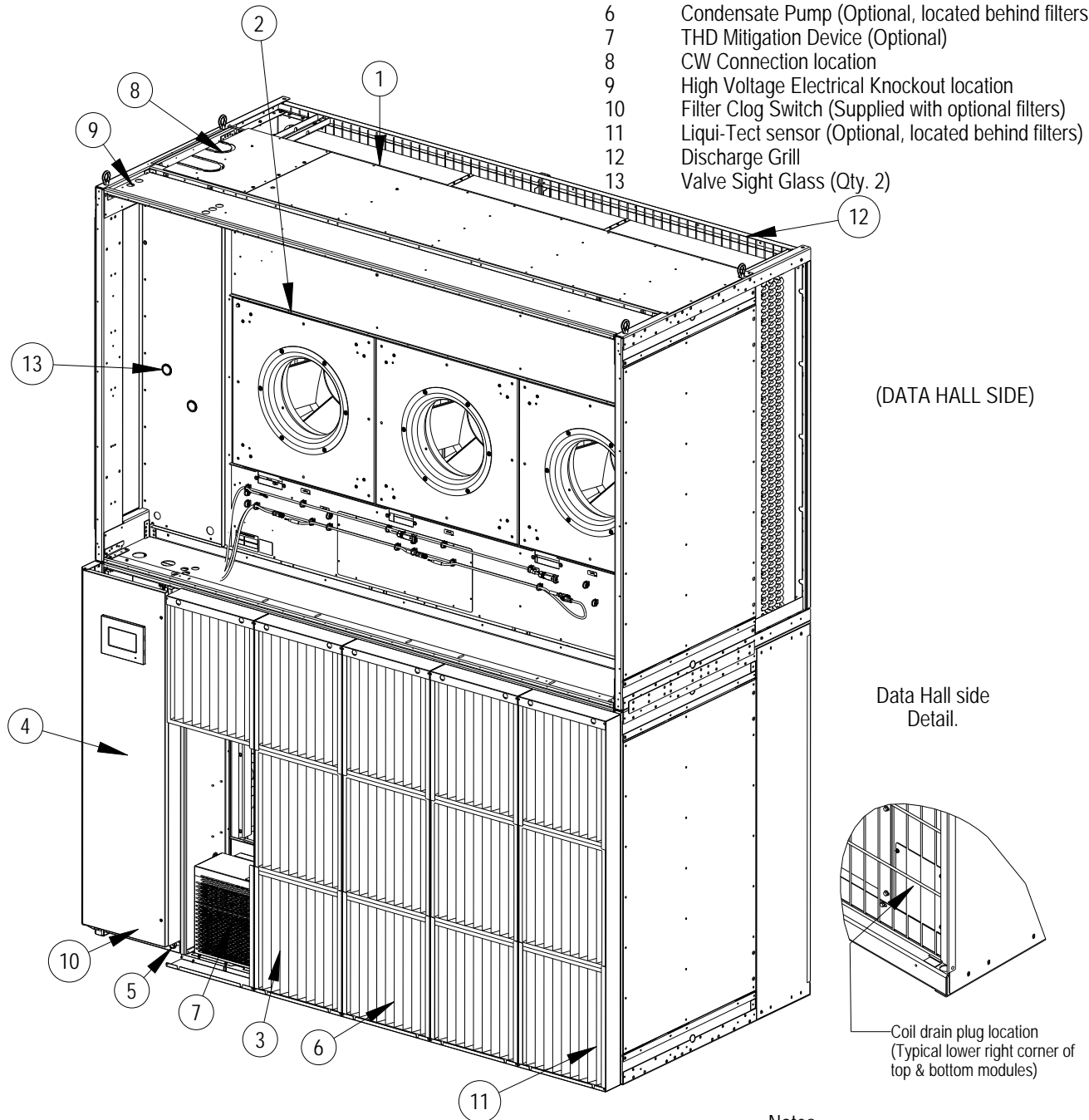

Notes:
1. Some items not shown for clarity.

(GALLERY SIDE)

**CABINET & ANCHOR DIMENSIONAL DATA
BOTTOM AND TOP MODULES**

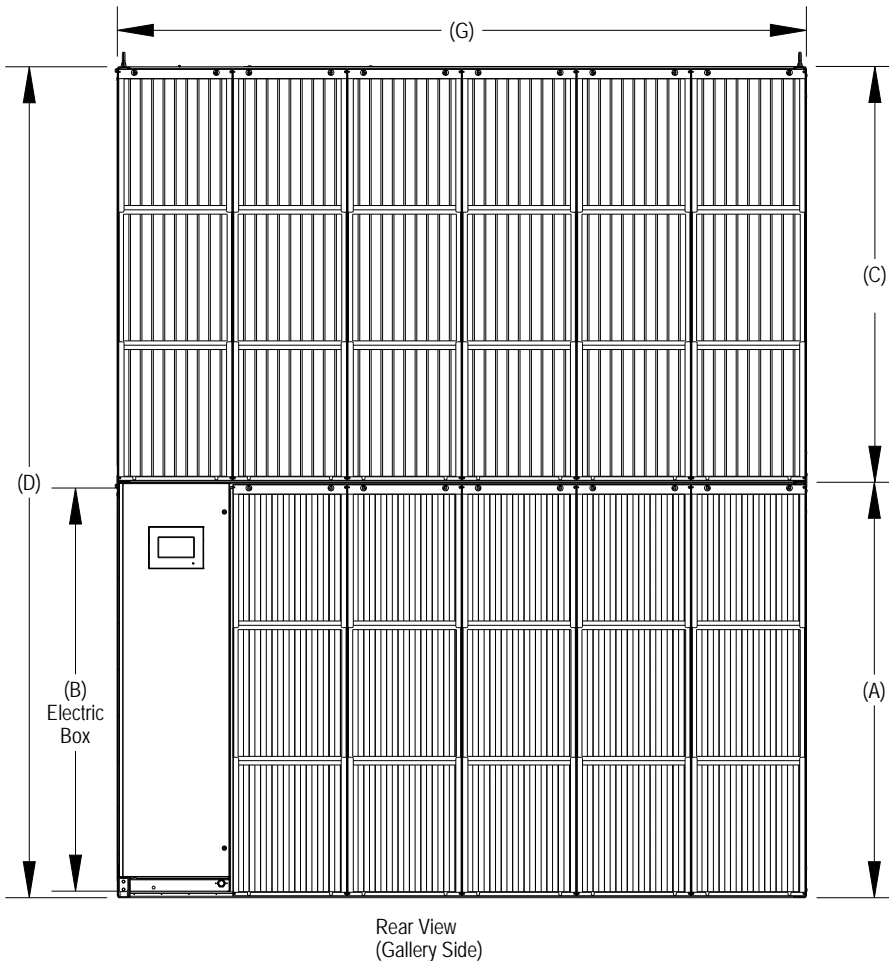
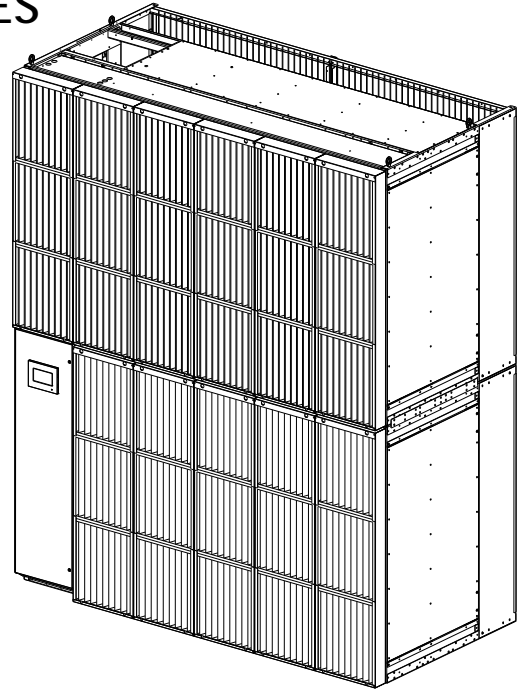
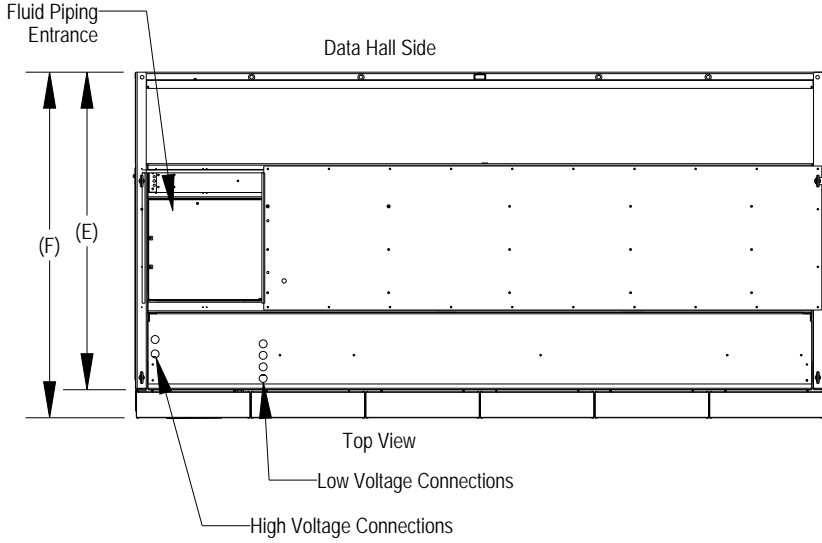

Chilled Water Model Number		CA60
Dimensional Data mm. [inch]	A	1832 [72.13]
	B	1778 [69.99]
	C	1834 [72.19]
	D	3664 [144.26]
	E	1400 [55.13]
	F	1524 [60.00]
	G	3039 [119.63]

- Notes:
1. Filters are accessible on the Gallery Side.
 2. See Sheet 2 for Anchoring Dimensions.

CABINET & ANCHOR DIMENSIONAL DATA BOTTOM MODULE

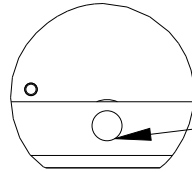

Ø5/8" (16mm) mounting holes (To Ground)(contact points) TYP. 11 places 

Detail A

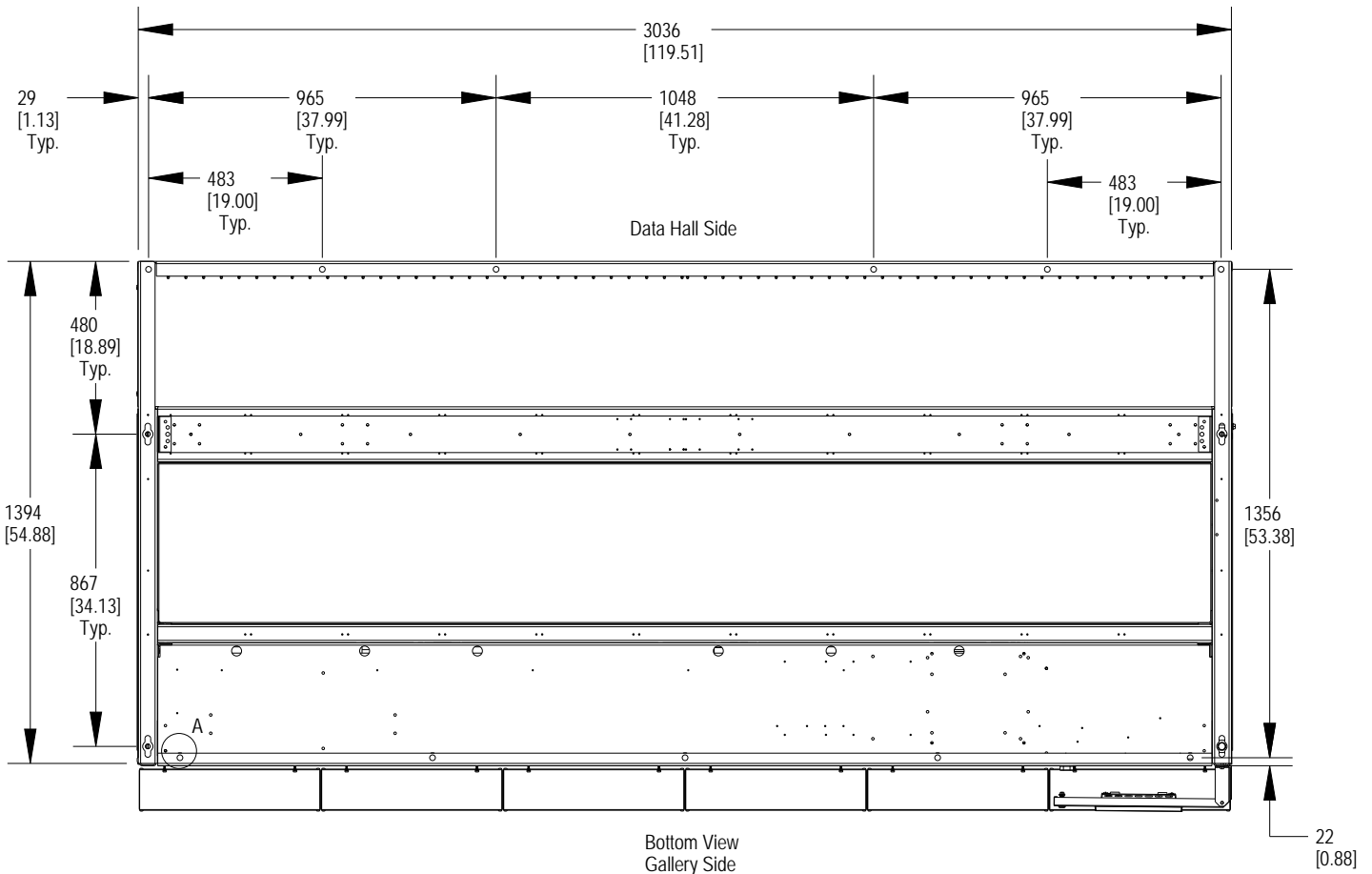

Notes:

1. Underside of unit. All components not part of the bottom frame removed for clarity.

 2. Eleven (11) Floor mounting holes and (11) 1/2" field supplied bolts required to secure unit base to customer support structure. Bolt grade to be specified by local requirements.



LIEBERT[®] CWA

CABINET & ANCHOR DIMENSIONAL DATA WEIGHTS

Unit Weights

	Module Dry Weight kg (lbs.)	Operating Weight kg (lbs.)	Module Domestic Pack kg (lbs.)	Module Export Pack kg (lbs.)
Top Module (with Coil and Fans)	1242 (2738)	1378 (3038)	1412 (3113)	1436 (3168)
Bottom Module (with Coil, Fans and Electrical Box)	1417 (3123)	1552 (3423)	1587 (3498)	1612 (3553)

Packaging Dimensions (All Units)

	Domestic Pack Dimensions L x W x H mm (inch)	Export Pack Dimensions L x W x H mm (inch)
Top Module	3352 x 1778 x 2159 (132 x 70 x 85)	3352 x 1778 x 1981 (132 x 70 x 78)
Bottom Module	3352 x 1778 x 2235 (132 x 70 x 88)	3352 x 1778 x 2261 (132 x 70 x 89)

Notes:

 Weights reflect heaviest configuration

INSTALLATION AND SERVICE CLEARANCE

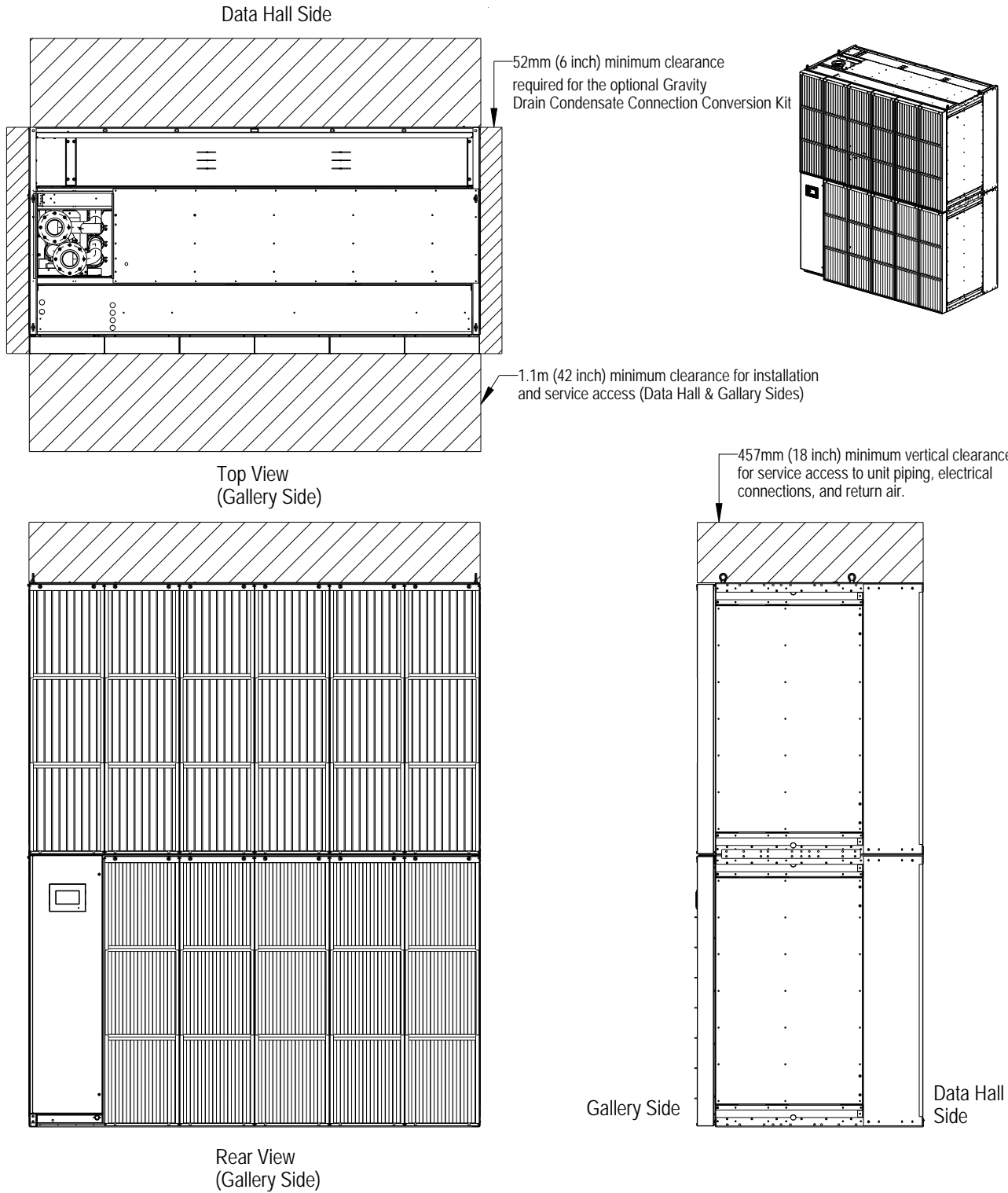



LIEBERT® CWA

FLOOR PLANNING FOR ADJACENT UNITS

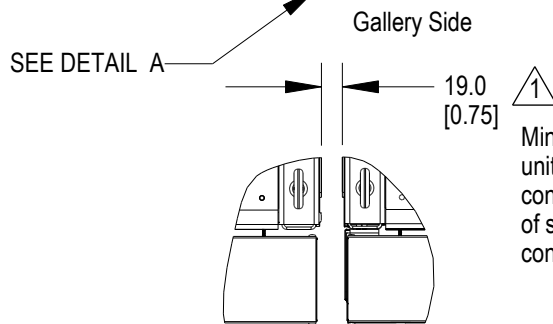
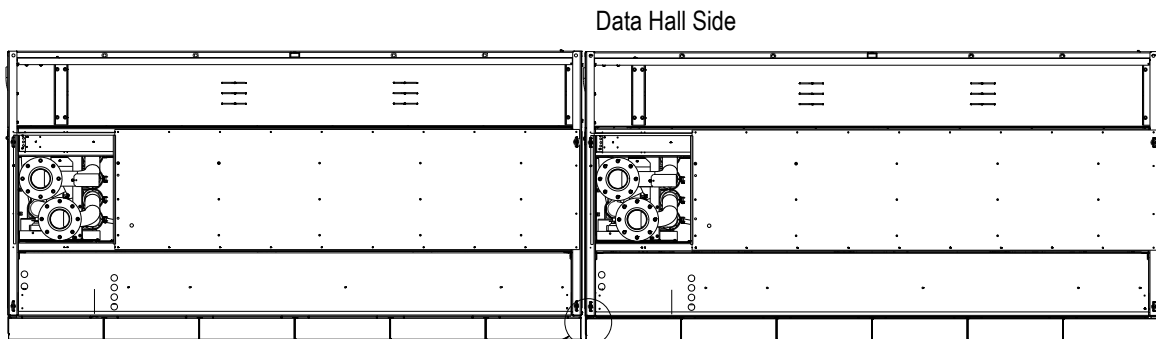
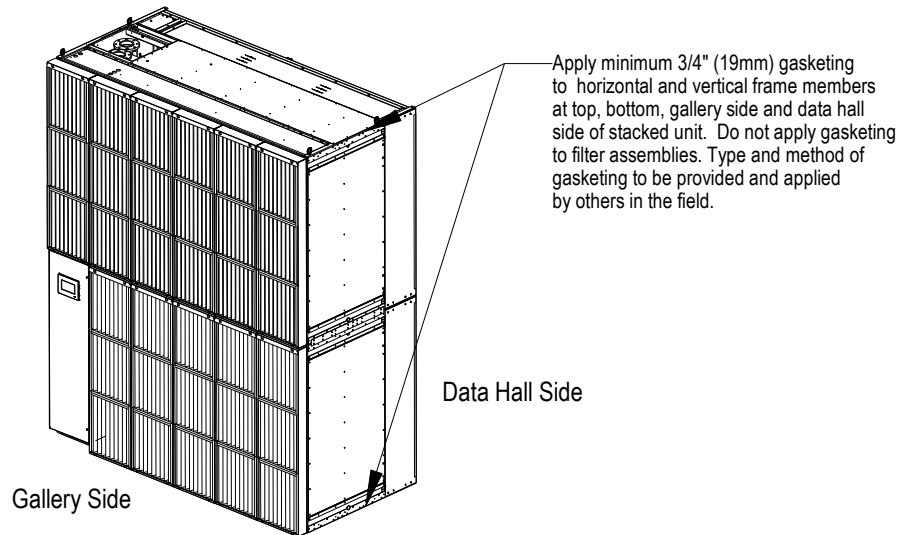

Minimum Gap to be filled with gasketing between units that do not have the gravity condensate connection conversion kit. Apply 152 mm (6 in) of side clearance when a gravity condensate connection conversion kit is installed.

Detail A

Notes:

\triangle 1. Gap is measured between frame members of adjacent units.

AIRFLOW SCHEMATIC

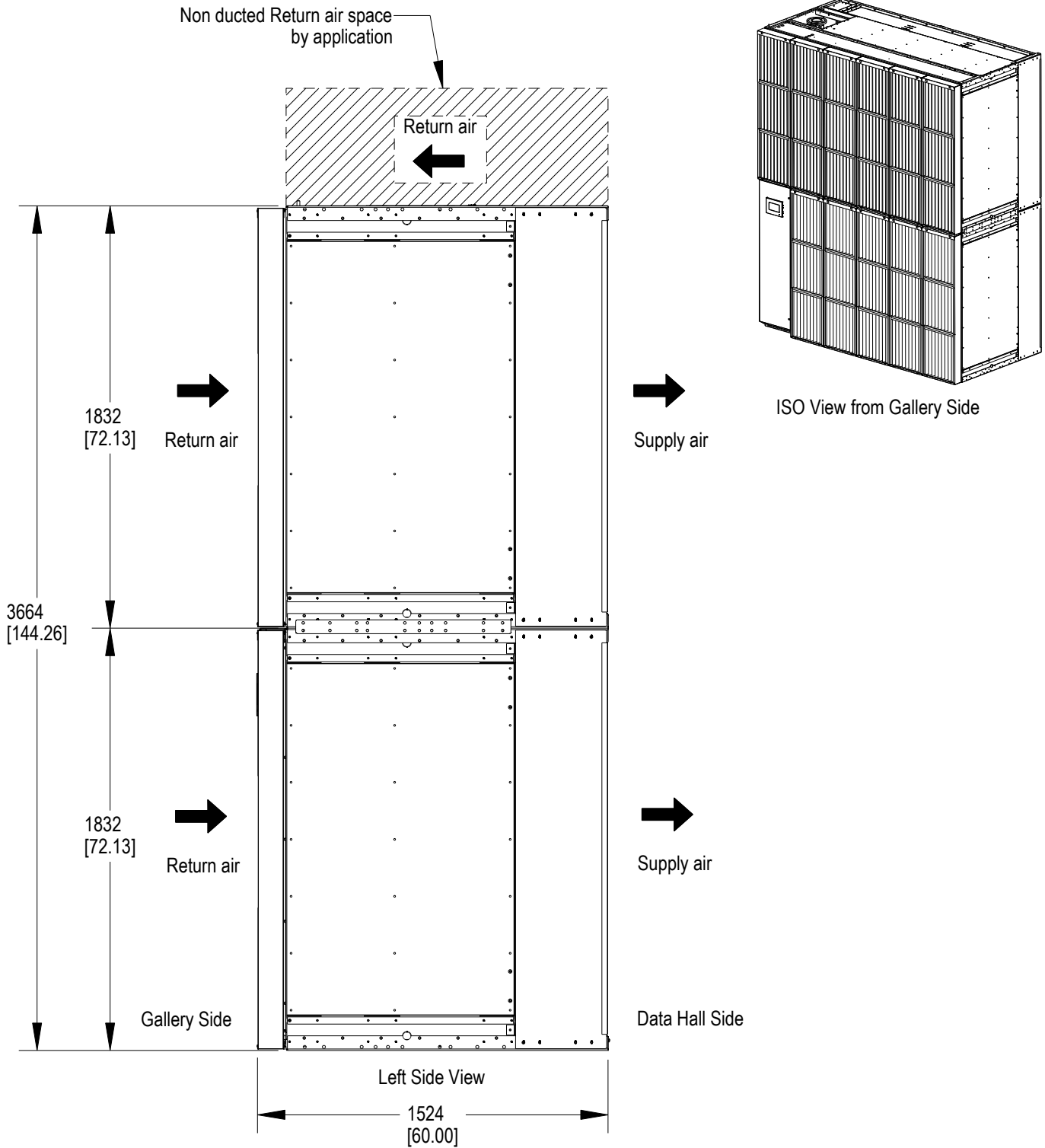



LIEBERT[®] CWA

SEISMIC APPLICATION ASSUMPTIONS AND REQUIREMENTS

Vertiv has conducted analytical modeling of the Liebert[®] CWA product to provide an option for those systems requiring seismic certification of compliance. This certification goes beyond the equipment's ability to withstand the seismic forces: the IBC (International Building Code) and ASCE (American Society of Civil Engineers) system approach includes the equipment, equipment anchorage, and the connections to the equipment [power, piping, and ducting].

Certification Criteria

The Liebert[®] CWA certification is based on a maximum mapped, maximum considered earthquake spectral response acceleration value, S_s , of 1.125g adjusted by the soil site coefficient to Soil Site Class D as the default when the site soil properties or final equipment installation location is not known. The certification maximum spectral response coefficient is S_{ds} value of .75g including Soil Class and Seismic Use group corrections. Soil Classes A, B, C, D, and E, and Seismic Design Categories A, B, C, D, E, and F are all covered under this certification, limited by the S_{ds} value stated above. Structural analysis has been conducted to demonstrate that the equipment meets performance objectives required for a component importance factor (I_p) of 1.0. Specifically, structural integrity is demonstrated such as to not pose a life safety hazard. A Liebert[®] CWA, as described above, is approved for seismic application as a system when properly installed in the following configurations:

- Liebert[®] CWA unit, with factory-installed seismic option, attached directly to a housekeeping pad using the anchoring system defined in this document.
- The certification excludes all non-Vertiv supplied accessories, including but not limited to floor stands, and isolators.

Certification	IBC	
Internal Bracing Option	Factory installed	
Unit	S_{ds}	I_p
CA060 (Top and Bottom Module)	.75	1.0

SEISMIC APPLICATION ASSUMPTIONS AND REQUIREMENTS

Requirements for Anchorage

Anchors

1. Mounting requirement details such as brand, type, embedment depth, edge spacing, anchor spacing, concrete strength, wall bracing, and special inspection must be outlined and approved by the project Structural Engineer of Record.

Anchorage Surface

2. Structural floors and housekeeping pads must also be seismically designed and approved by the project Structural Engineer of Record to withstand the seismic anchor loads as defined on the installation drawings. The installing contractor is responsible for the proper installation of all anchors and mounting hardware, observing the mounting requirement details outlined by the Engineer of Record. Contact the Manufacturer's Representative if a detailed Seismic Installation Calculation Package is required.

Unit Field Connections

3. Piping Field Connections: All units, either rigidly mounted or mounted on vibration isolators, shall be attached to the piping system using flexible loops designed for seismic movement. Flexible loops shall be capable of movement in the three axes and must completely isolate the equipment from the piping. The loops shall be suitable for an operating pressure and temperature of the system, refer to Vertiv installation instructions. This includes condensate drainage, and chilled water supply and return. Follow manufacturer's installation instructions for proper seismic application of flexible looping.

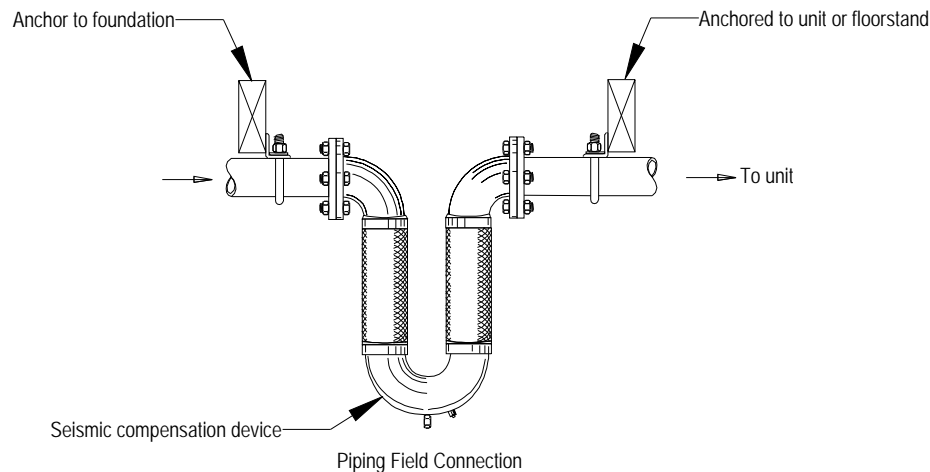

4. Electrical Connections: Must have adequate flexibility for seismic movement. Electrical wiring, conduit, and/or other connections to the equipment is the responsibility of others. Data and recommendations are supplied here and in the unit installation supplement for seismic installation.

DIMENSIONAL DATA SEISMIC MOUNTING (W/O ANCHOR BRACKETS)

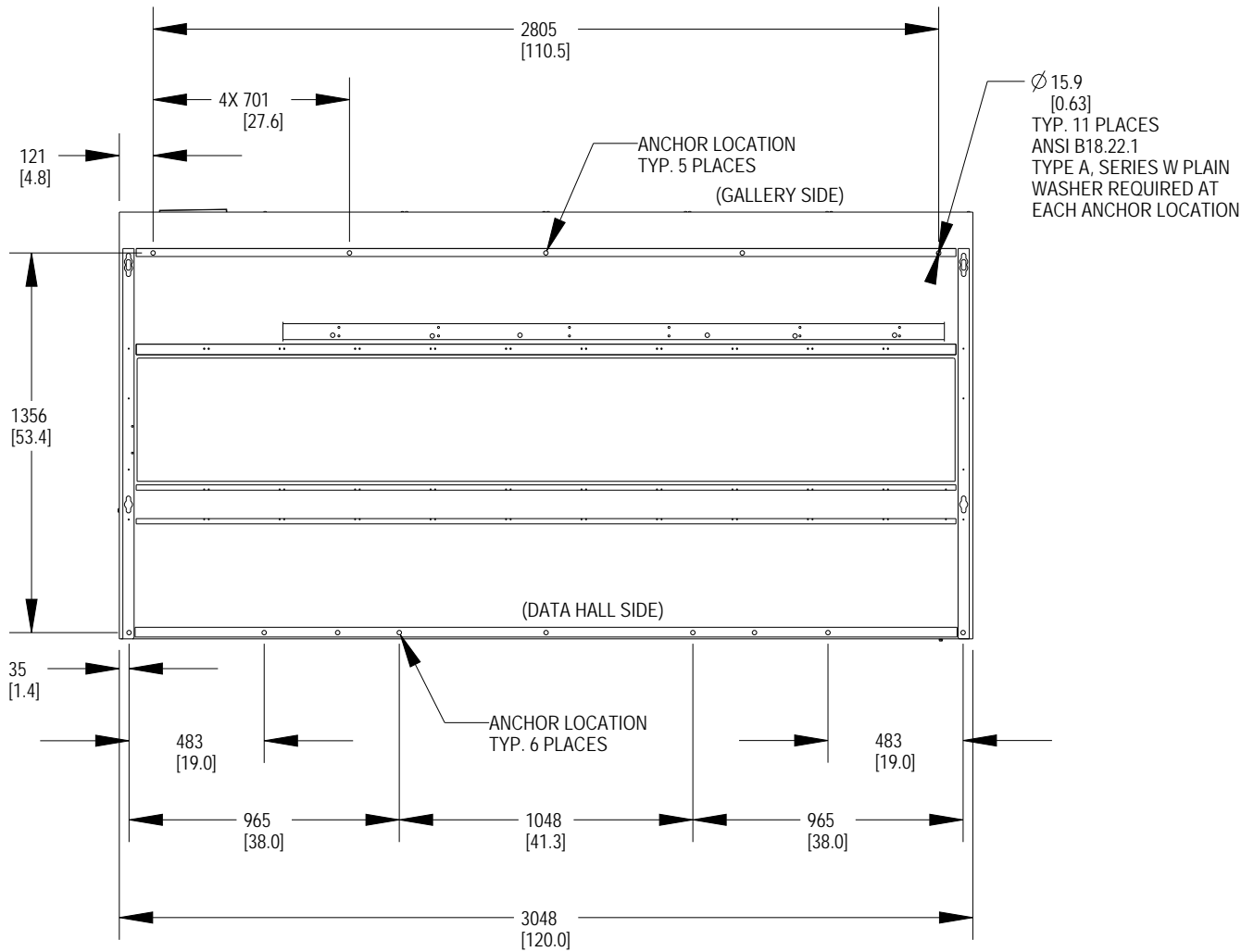

FLOOR ANCHORING DIMENSIONS (BOTTOM VIEW OF THE UNIT)

Notes:

1. Anchor Bolt sized per Engineer of Record.
2. Specified by Engineer of Record.



LIEBERT[®] CWA

SEISMIC APPLICATION ASSUMPTIONS AND REQUIREMENTS

Vertiv has conducted analytical modeling of the Liebert CWA product to provide an option for those systems requiring seismic certification of compliance. This certification goes beyond the equipment's ability to withstand the seismic forces: the IBC (International Building Code) and ASCE (American Society of Civil Engineers) system approach includes the equipment, equipment anchorage, and the connections to the equipment [power, piping, and ducting].

Certification Criteria

The Liebert CWA certification is based on a maximum mapped, maximum considered earthquake spectral response acceleration value, S_s , of 1.125g adjusted by the soil site coefficient to Soil Site Class D as the default when the site soil properties or final equipment installation location is not known. The certification maximum spectral response coefficient is S_{ds} value of 2.5g including Soil Class and Seismic Use group corrections. Soil Classes A, B, C, D, and E, and Seismic Design Categories A, B, C, D, E, and F are all covered under this certification, limited by the S_{ds} value stated above. Structural analysis has been conducted to demonstrate that the equipment meets performance objectives required for a component importance factor (I_p) of 1.0. Specifically, structural integrity is demonstrated such as to not pose a life safety hazard. A Liebert CWA, as described above, is approved for seismic application as a system when properly installed in the following configurations:

- Liebert CWA unit, with factory-installed seismic option, attached directly to a housekeeping pad using the anchoring system defined in this document.
- The certification excludes all non-Vertiv supplied accessories, including but not limited to floor stands, and isolators.

Certification	IBC	
Internal Bracing Option	Factory installed	
Unit	S _{ds}	I _p
CA060 (Top and Bottom Module)	2.5	1.0

SEISMIC APPLICATION ASSUMPTIONS AND REQUIREMENTS

Requirements for Anchorage

Anchors

1. Mounting requirement details such as brand, type, embedment depth, edge spacing, anchor spacing, concrete strength, wall bracing, and special inspection must be outlined and approved by the project Structural Engineer of Record.

Anchorage Surface

2. Structural floors and housekeeping pads must also be seismically designed and approved by the project Structural Engineer of Record to withstand the seismic anchor loads as defined on the installation drawings. The installing contractor is responsible for the proper installation of all anchors and mounting hardware, observing the mounting requirement details outlined by the Engineer of Record. Contact the Manufacturer's Representative if a detailed Seismic Installation Calculation Package is required.

Unit Field Connections

3. Piping Field Connections: All units, either rigidly mounted or mounted on vibration isolators, shall be attached to the piping system using flexible loops designed for seismic movement. Flexible loops shall be capable of movement in the three axes and must completely isolate the equipment from the piping. The loops shall be suitable for an operating pressure and temperature of the system, refer to Vertiv installation instructions. This includes condensate drainage, and chilled water supply and return. Follow manufacturer's installation instructions for proper seismic application of flexible looping.

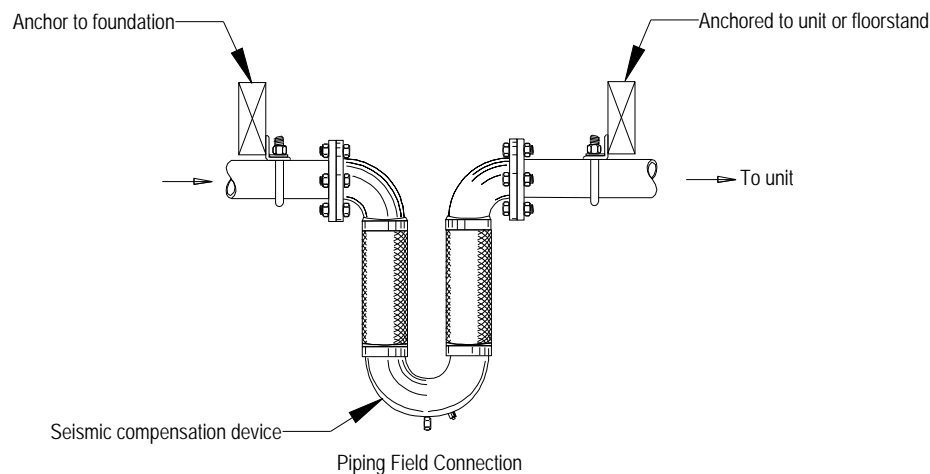

4. Electrical Connections: Must have adequate flexibility for seismic movement. Electrical wiring, conduit, and/or other connections to the equipment is the responsibility of others. Data and recommendations are supplied here and in the unit installation supplement for seismic installation.

DIMENSIONAL DATA SEISMIC 2.5 Sds MOUNTING

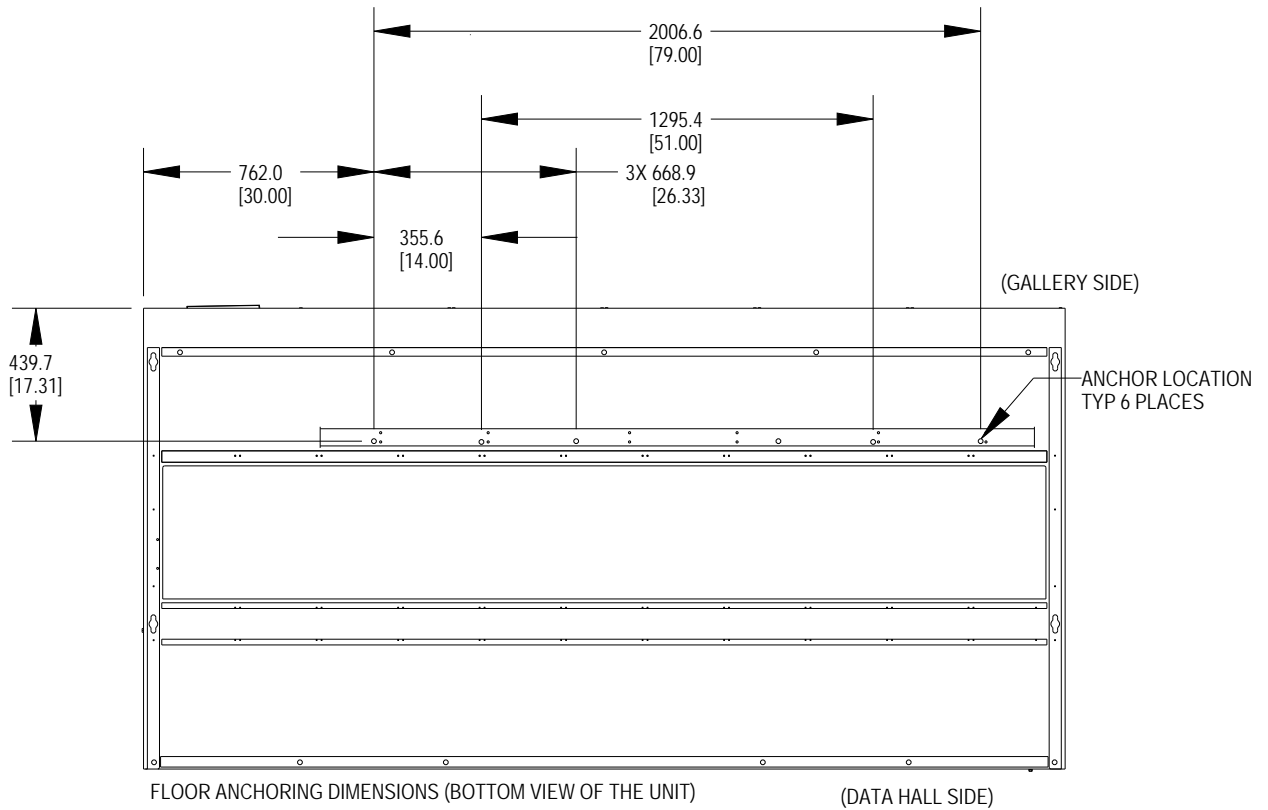

- Notes:
1. Anchor Bolt sized per Engineer of Record.
 2. Specified by Engineer of Record.
 3. Refer to DPN005188 for mounting of 2.5 Sds units during installation. Plan for prior to anchoring.

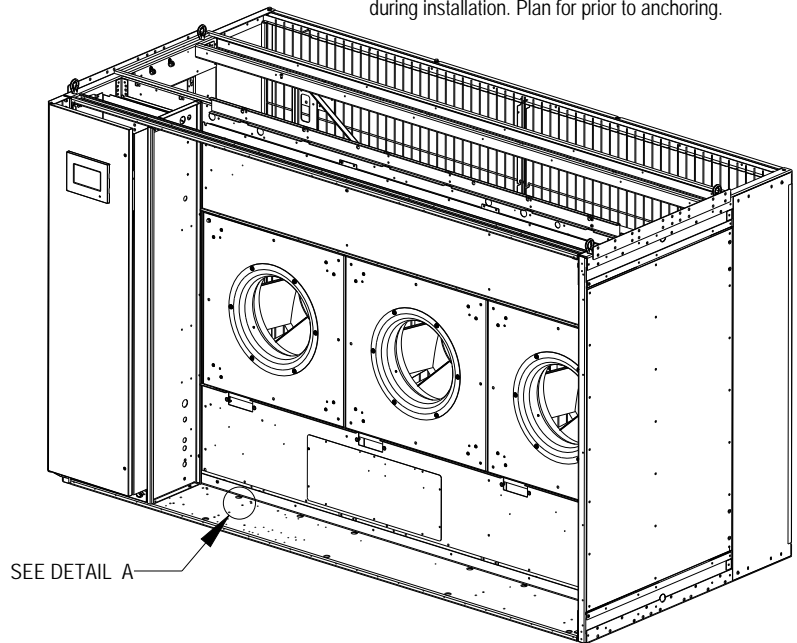
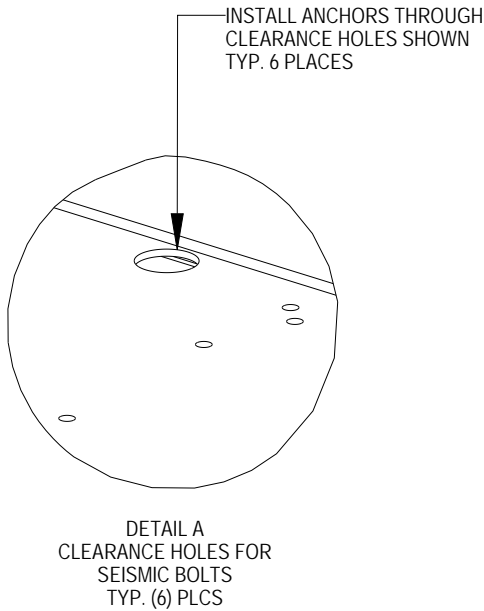

FILTER AND FILTER RACK REMOVAL

FILTERS ARE REMOVED FROM CENTER POSITION OF THE FILTER RACK.

LIFT THE FILTER UP AND OUT TO REMOVE FROM RACK.

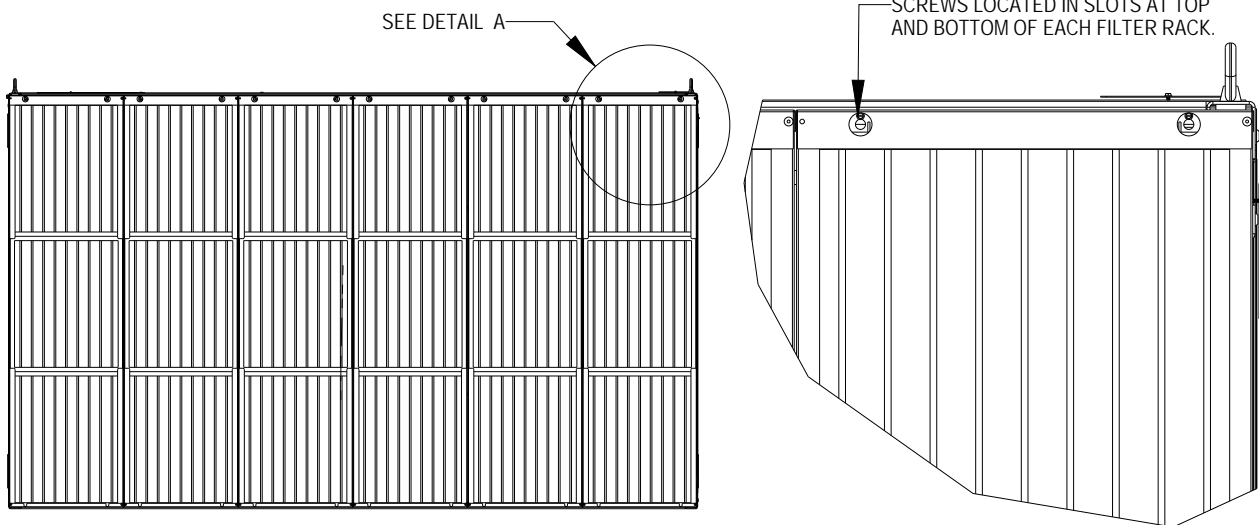
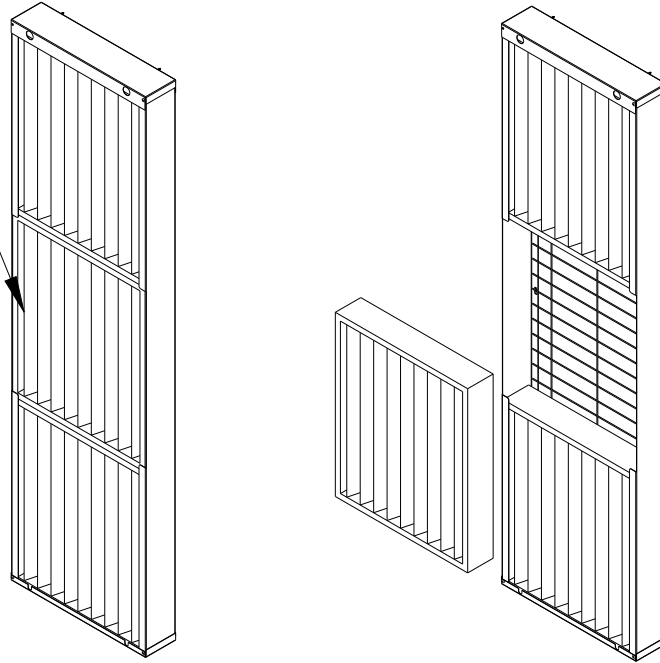

FILTER RACK REMOVAL INSTRUCTIONS

1. REMOVE FILTERS FROM RACK.
2. LOOSEN (2) SCREWS AT THE TOP AND BOTTOM OF FILTER RACK.
3. LIFT FILTER RACK UP AND OUT TO REMOVE THE RACK.

TOP AND BOTTOM MODULE ASSEMBLY

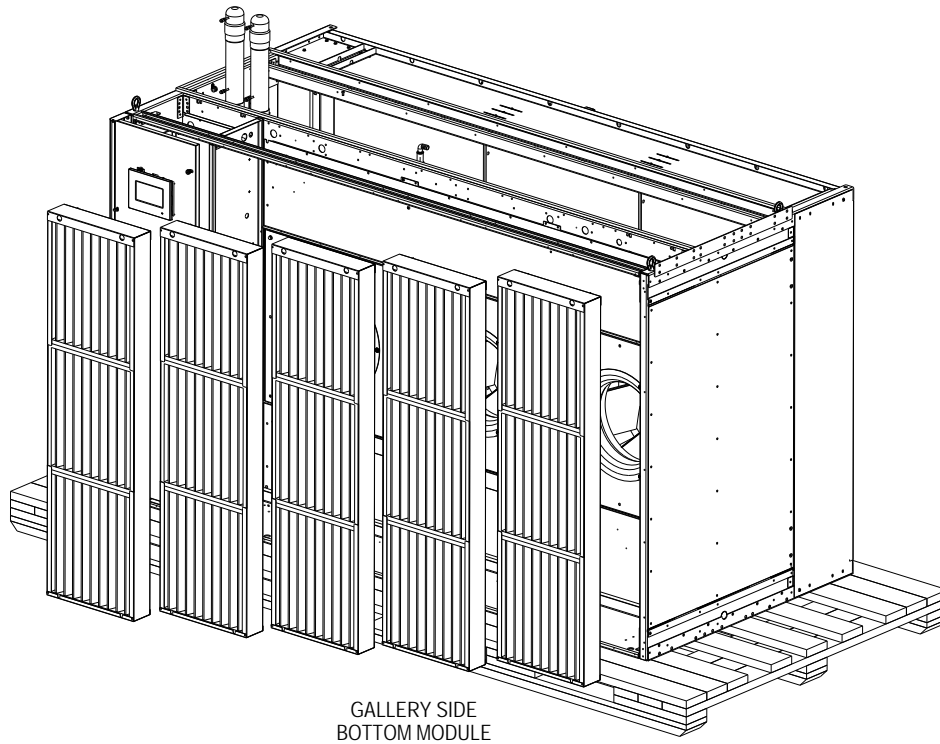
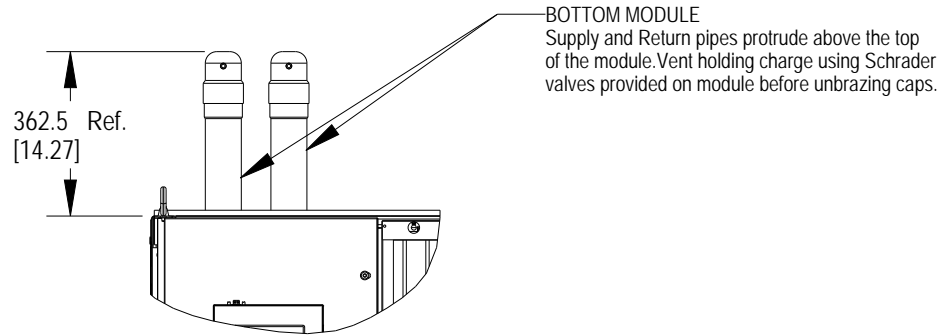

Notes:

- 1) Remove exterior packaging material from module.
- 2) Unit ships in two sections, Top module and Bottom module.
- 3) Each module is fastened to the shipping skid with Lag screws through the provided mounting holes.
- 4) Remove filter rack assemblies from each module. (See DPN005164 for details on filter rack removal)

Refer to Liebert® CWA user manual for detailed installation instructions

TOP AND BOTTOM MODULE ASSEMBLY

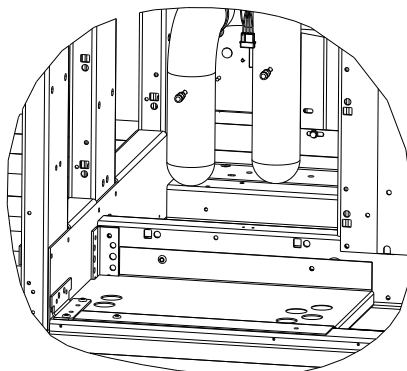
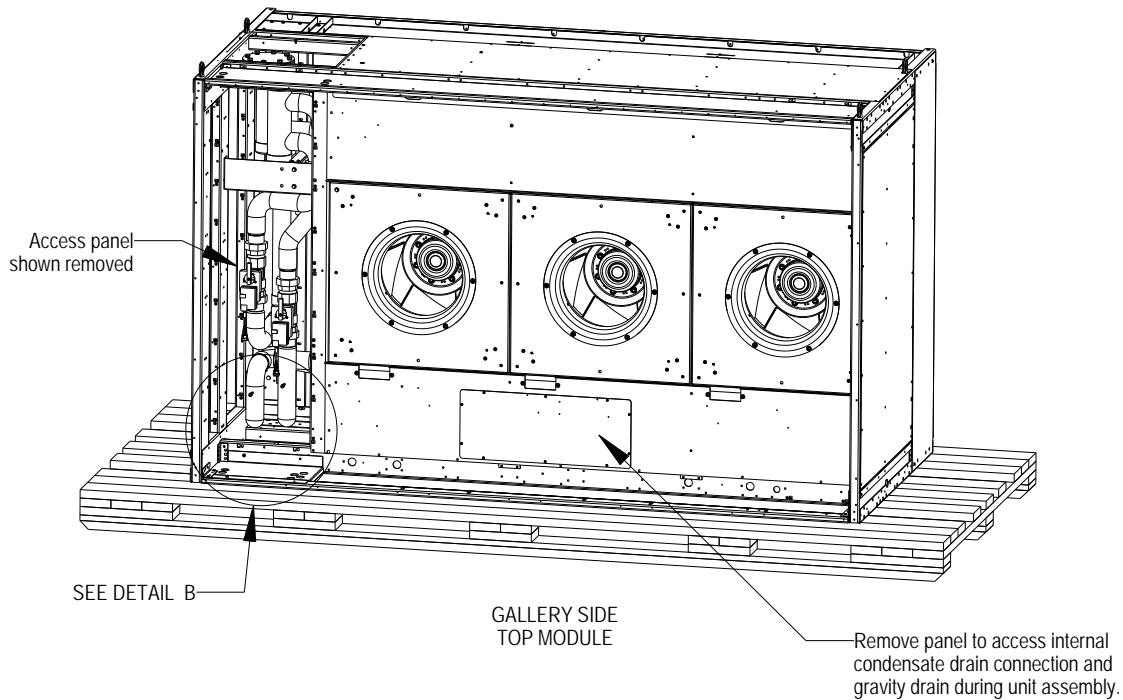

DETAIL B
Spun closed

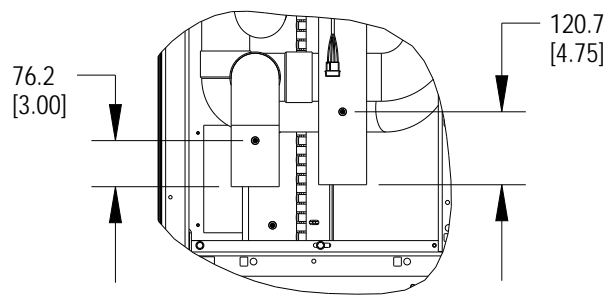

DIMENSIONS REQUIRED FOR
CONNECTION TO BOTTOM MODULE

Notes:

- 1) On Top Module, remove Panel to access the internal piping for the supply and return connections.
- 2) Vent holding charge using Schrader valves provided on module before removing any fittings.
- 3) Prepare internal piping connections by cutting to dimensions specified in above details.
Remove any excess piping material using a tube cutter or other non burring device. Clean up shavings and other materials before making supply and return piping connections.
- 4) If the optional Gravity Drain Condensate Connection Conversion Kit has been purchased, reference the factory provided document (doc# 10021579) for installation steps.

Refer to Liebert® CWA user manual for detailed installation instructions



LIEBERT® CWA

TOP AND BOTTOM MODULE ASSEMBLY

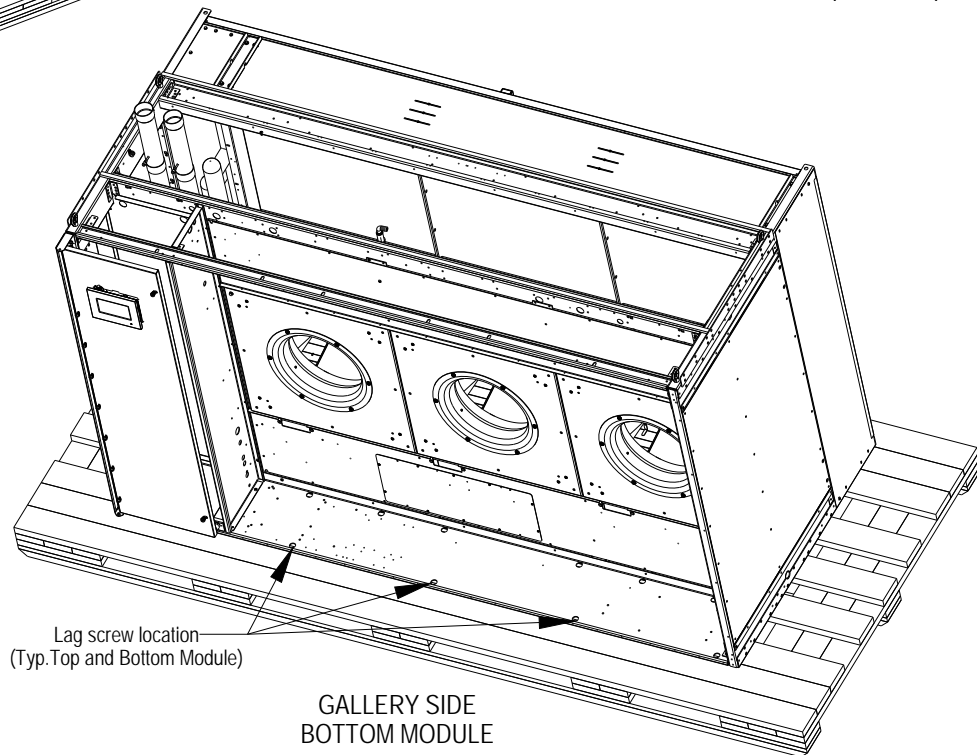
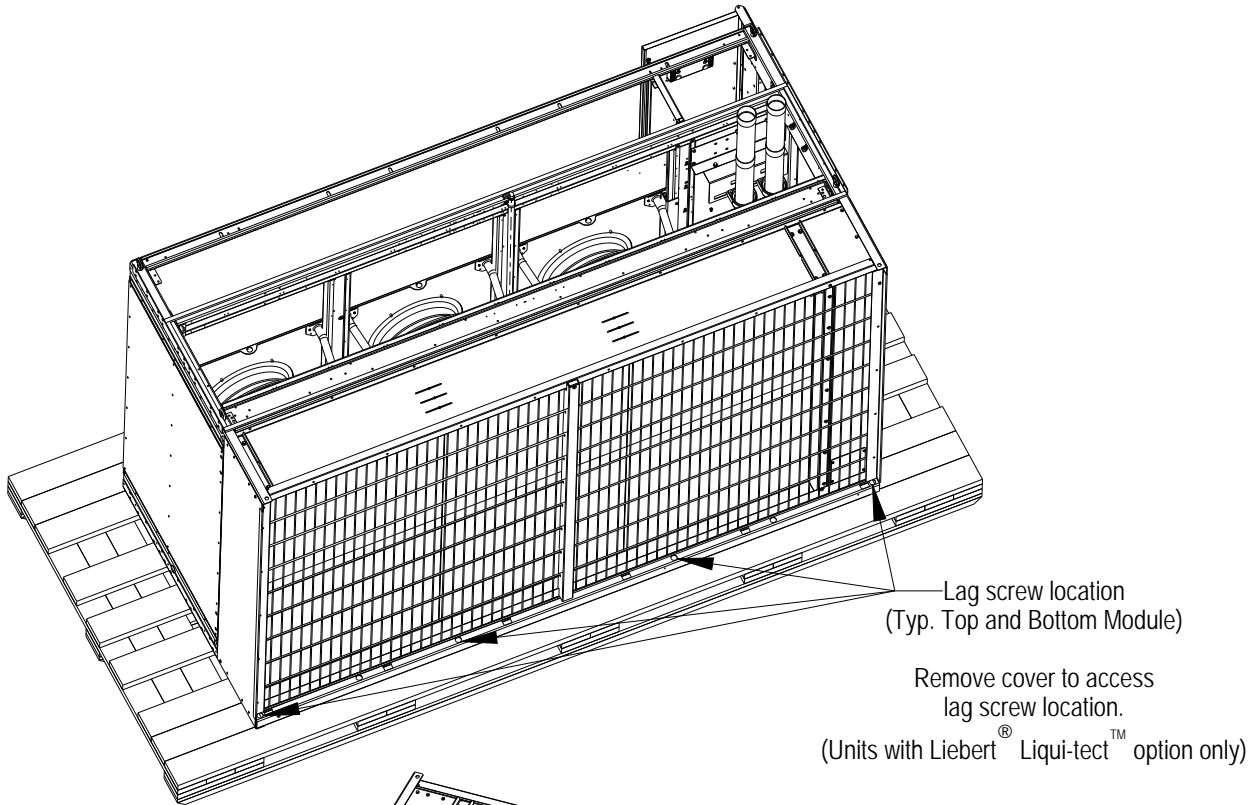

- Notes:
- 1) Unbolt Lag screws from skid on Top and Bottom Module.
 - 2) For 2.5 Sds seismic rated units, field must reinstall rear bracing per page 6 of 6

Refer to Liebert® CWA user manual for detailed installation instructions

TOP AND BOTTOM MODULE ASSEMBLY

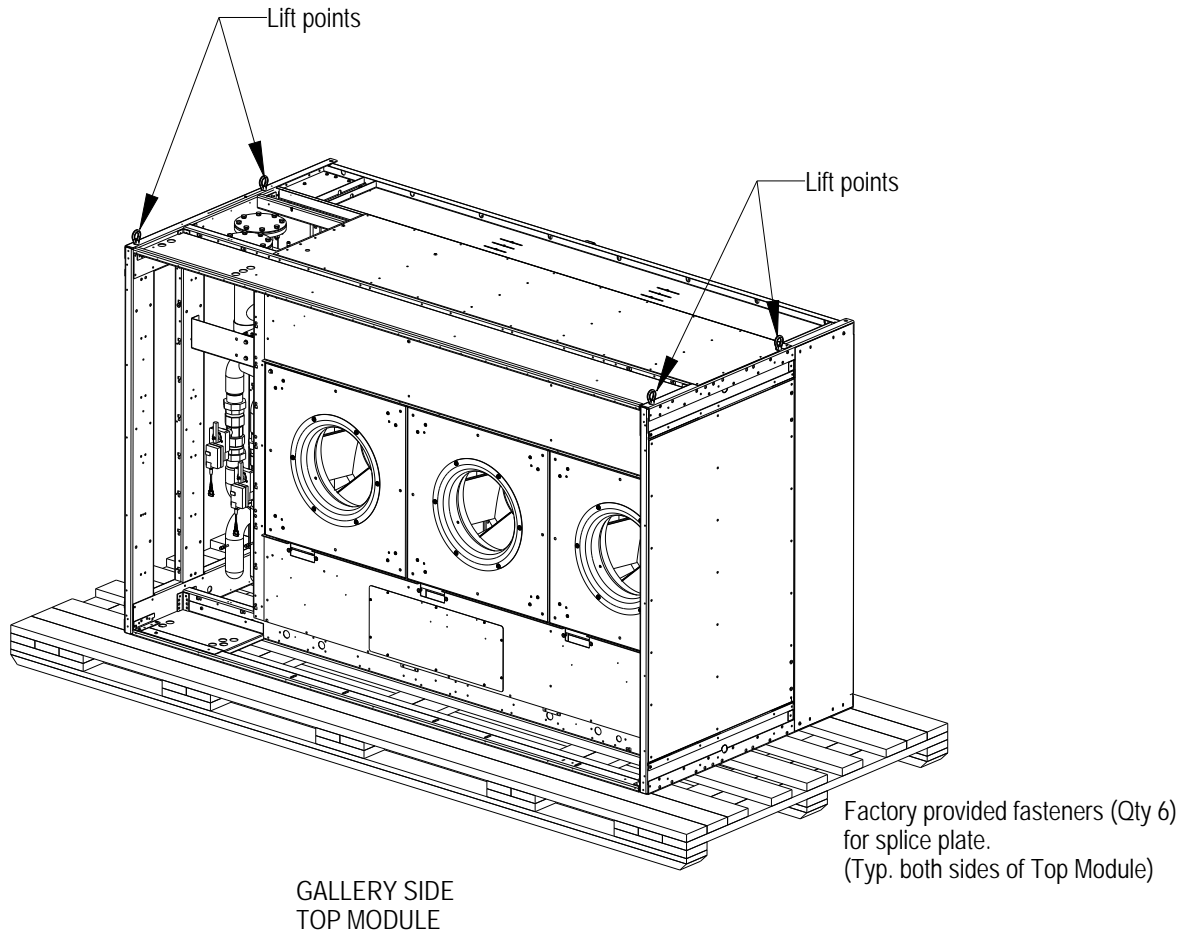

Note:

- Lifting force must be completely vertical at each lift point location.

Refer to Liebert® CWA user manual for detailed installation instructions

TOP AND BOTTOM MODULE ASSEMBLY

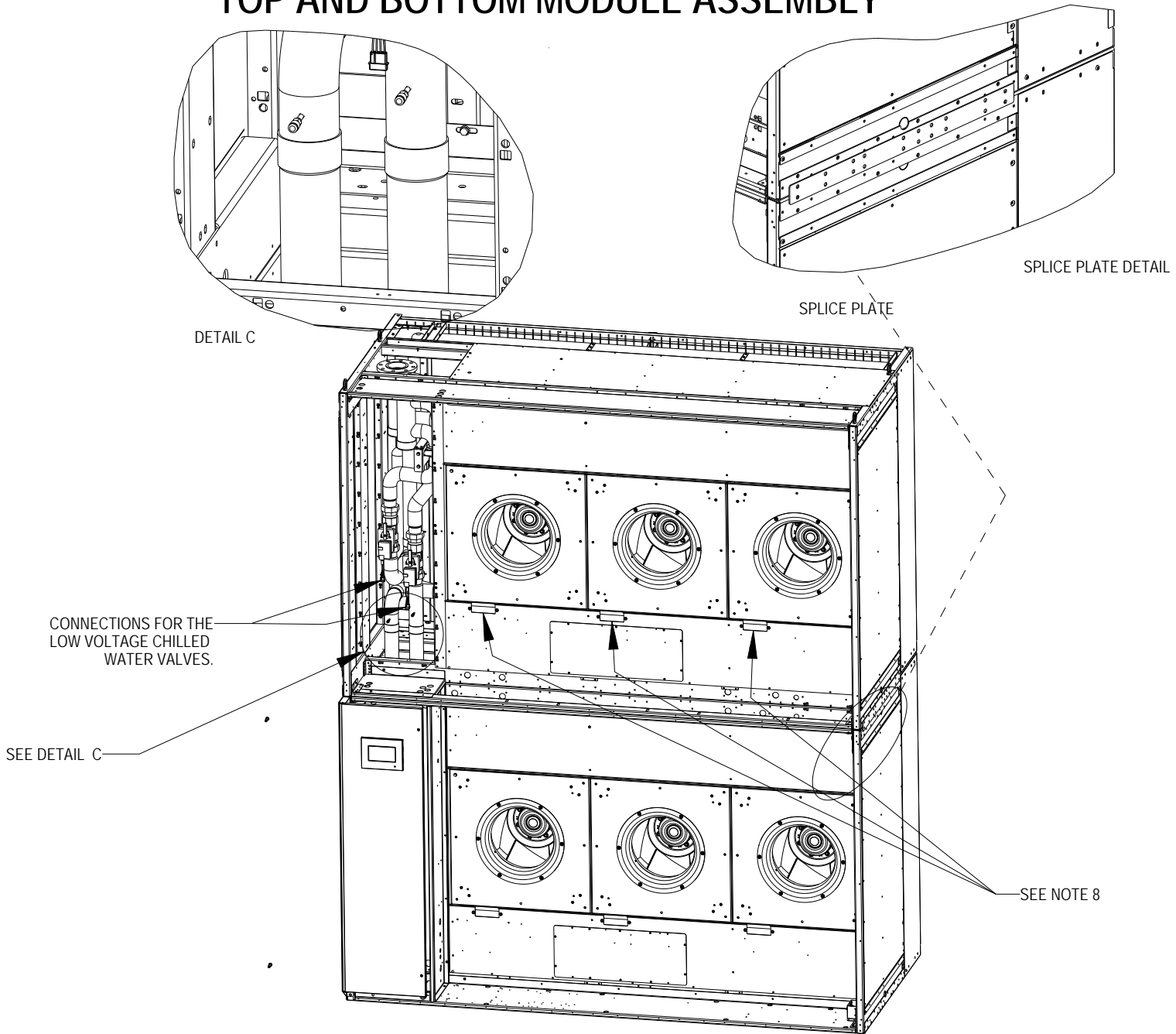

Notes:

- 1) Field must use a professional rigger to lift and assemble the top and bottom module.
- 2) Modules must be fastened together with factory provided splice plate and fasteners. (Typ. both sides)
- 3) Braze internal piping connections.
- 4) Assemble internal Condensate connection between Top and Bottom Module. (See DPN005193 for details)
- 5) Leak check assembled unit.
- 6) Field must use a professional rigger to move the assembled unit into place. (See DPN005036 for Bottom Module Mounting. For 2.5 Sds seismic rated units, field must reinstall rear bracing per page 6 of 6)
- 7) Complete electrical connection for the low voltage Chilled Water valves and then reattach panel covers on Top Module piping section and Top and Bottom Module lifting points.
- 8) Complete electrical connections for Top Module fans then Reinstall filter racks on Top and Bottom Module.
- 9) See User Manual to complete unit installation.

Refer to Liebert® CWA user manual for detailed installation instructions

TOP AND BOTTOM MODULE ASSEMBLY EXTERNAL BRACING FOR SEISMIC UNITS

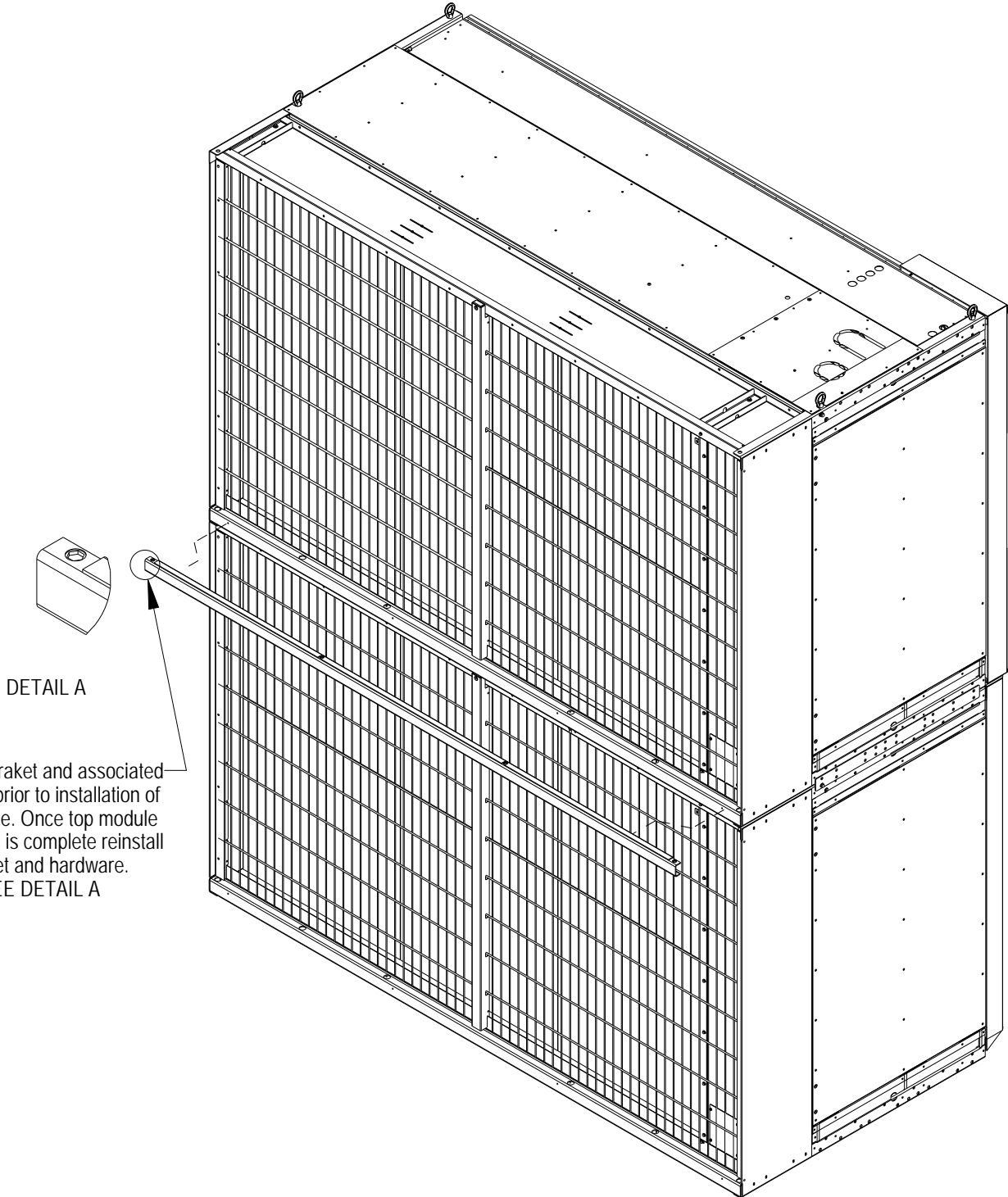

DETAIL A

Remove bracket and associated hardware prior to installation of top module. Once top module installation is complete reinstall bracket and hardware. SEE DETAIL A



ELECTRICAL FIELD CONNECTIONS

STANDARD ELECTRICAL CONNECTIONS

1. High voltage entrance - Located in the top of the box (quantity 2).
2. Low voltage entrance - Located in the top of the box (quantity 1-4).
3. Three phase electrical service - Terminals are on top of disconnect switch. Three phase service not provided by Liebert.
4. Earth ground - Terminal for field supplied earth grounding wire and component ground terminal strip. Earth grounding required for Liebert units.
5. Unit factory installed disconnect switch and Main Fuses - Access to the high voltage electric panel compartment can be obtained only with the switch in the "off" position. Fused disconnects are provided with a defeater button that allows access to the electrical panel when power is on.
6. Remote unit shutdown - Replace existing jumper between terminals 37 & 38 with field supplied normally closed switch having a minimum 75VA, 24VAC rating. Use field supplied Class 1 wiring.
7. Customer alarm inputs - Terminals for field supplied, normally open contacts, having a minimum 75VA, 24VAC rating, between terminals 24 & 50, 51, 55, 56. Use field supplied Class 1 wiring. Terminal availability varies by unit options.
8. Common alarm - On any alarm, normally open dry contact is closed across terminals 75 & 76 for remote indication 1 AMP, 24VAC max load. Use Class 1 field supplied wiring.
9. Unit-to-Unit - Plug 64 is reserved for U2U communication
10. Site and BMS - Plug 74 and terminal block 3 are reserved for Site and BMS connections. Plug 74 is an eight pin RJ45 for a Cat 5 cable. Terminal block 3 is a two-position screw terminal block for use with twisted pair wires.

OPTIONAL LOW VOLTAGE TERMINAL PACKAGE CONNECTIONS

11. Remote unit shutdown - Two additional contact pairs available for unit shutdown (labeled as 37B & 38B, 37C & 38C). Replace jumpers with field supplied normally closed switch having a minimum 75VA, 24VAC rating. Use field supplied Class 1 wiring.
12. Extra Common alarm - On any alarm, two additional normally open dry contacts are closed across terminals 94 & 95 and 96 & 97 for remote indication. 1 AMP, 24VAC max load. Use Class 1 field supplied wiring.
13. Main fan enabled contact - On enable, normally open dry contact is closed across terminals 84 & 85 for remote indication. 1 AMP, 24VAC max load. Use Class 1 field supplied wiring.
14. Liebert® Liqui-Tect™ shutdown and dry contact - On LiquiTect activation, normally open dry contact is closed across terminals 58 & 59 for remote indication (LiquiTect sensor ordered separately). 1 AMP, 24VAC max load. Use Class 1 field supplied wiring.

OPTIONAL ELECTRICAL CONNECTIONS

15. Smoke sensor alarm - Factory wired dry contacts from smoke sensor are 91-common, 92-NO, and 93-NC. Supervised contacts, 80 & 81, open on sensor trouble indication. This smoke sensor is not intended to function as, or replace, any room smoke detection system that may be required by local or national codes. 1 AMP, 24VAC max load. Use Class 1 field supplied wiring.
16. Analog inputs- Terminals 41, 42, 43, and 44 are user configurable for 0-10V, 0-5V, or 4-20MA.
17. Condensate alarm (with condensate pump option) - On pump high water indication, normally open dry contact is closed across terminals 88 & 89 for remote indication. 1 AMP, 24VAC max load. Use Class 1 field supplied wiring.
18. Remote humidifier - On any call for humidification, normally open dry contact is closed across terminals 11 and 12 to signal field supplied remote humidifier. 1 AMP, 24VAC max load. Use Class 1 field supplied wiring

ELECTRICAL FIELD CONNECTIONS (SHOWN WITH DUAL POWER)

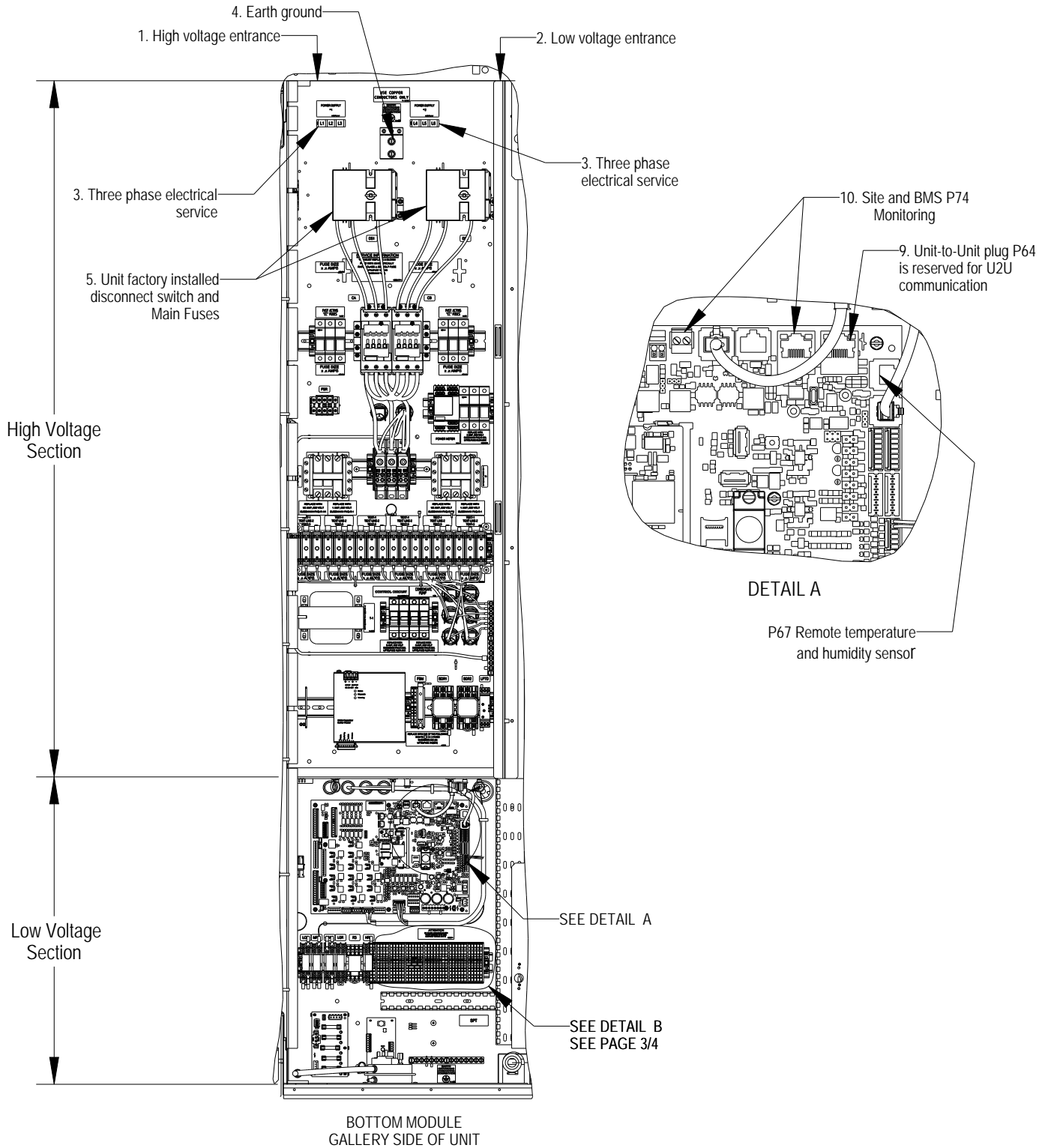

ELECTRICAL FIELD CONNECTIONS

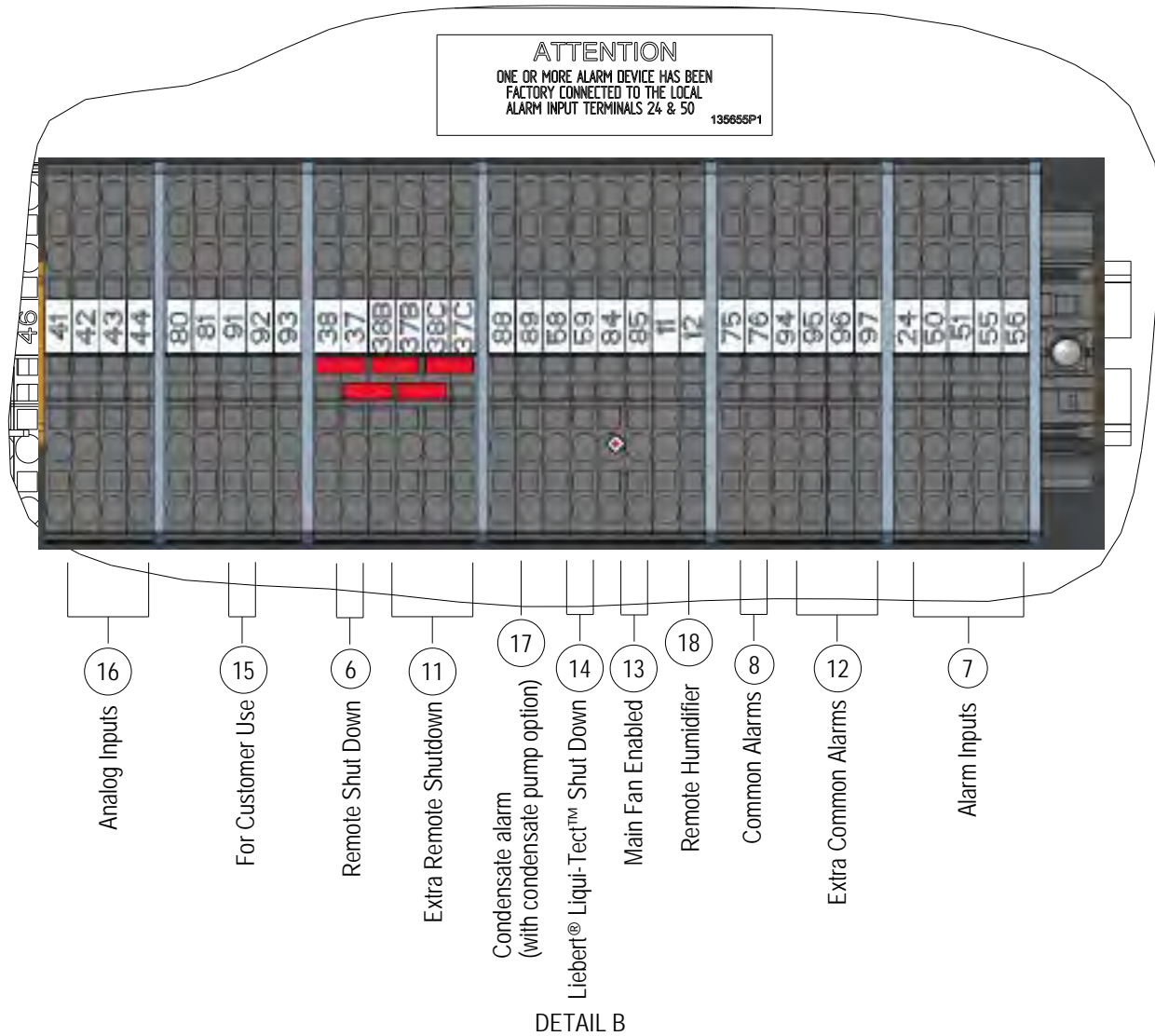

ELECTRICAL FIELD CONNECTIONS

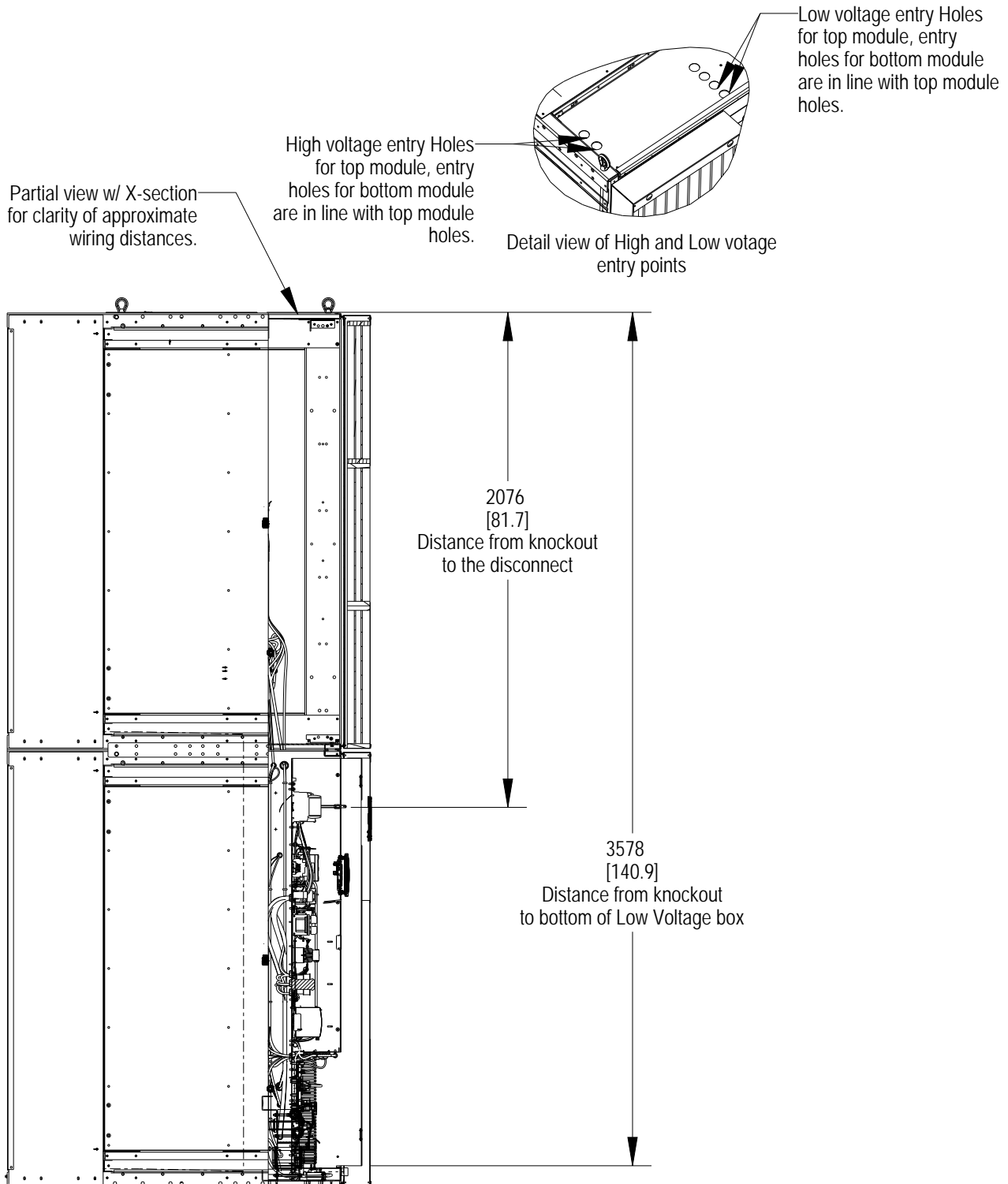

Note:

1. Filter and Filter rack assembly must be removed to access internal Electrical knockout



LIEBERT® CWA

ELECTRICAL DATA

Model	Fan Type	Voltage	without Condensate Pump			with Condensate Pump		
			FLA	WSA	OPD	FLA	WSA	OPD
CA60	Standard Fan (Qty 4)	460V/60Hz	18.0	19.1	20	19.2	20.3	25
		575V/60Hz	14.4	15.3	20	15.3	16.2	20
		380V/60Hz	21.6	23.0	25	22.8	24.2	25
	(Optional) High Static Fan (Qty 6)	380-415V/50Hz	21.6	23.0	25	22.8	24.2	25
		460V/60Hz	27.6	28.8	30	28.8	30.0	30
		575V/60Hz	22.1	23.0	25	23.0	23.9	25
	(Optional) High Airflow High Static Fan (Qty 6)	380V/60Hz	33.6	35.0	40	34.8	36.2	40
		380-415V/50Hz	33.6	35.0	40	34.8	36.2	40
		460V/60Hz	40.8	42.5	45	42.0	43.7	50
	(Optional) High Airflow High Efficiency Fan (Qty 6)	575V/60Hz	32.6	34.0	35	33.6	34.9	40
		380V/60Hz	51.0	53.1	60	52.2	54.3	60
		380-415V/50Hz	51.0	53.1	60	52.2	54.3	60
	(Optional) High Airflow High Efficiency Fan (Qty 6)	460V/60Hz	31.2	32.5	35	32.4	33.7	35
		575V/60Hz	25.0	26.0	30	25.9	26.9	30
		380V/60Hz	35.4	36.9	40	36.6	38.1	40
		380-415V/50Hz	35.4	36.9	40	36.6	38.1	40

PRIMARY CONNECTION LOCATIONS WITH BRAZED CUSTOMER CONNECTIONS

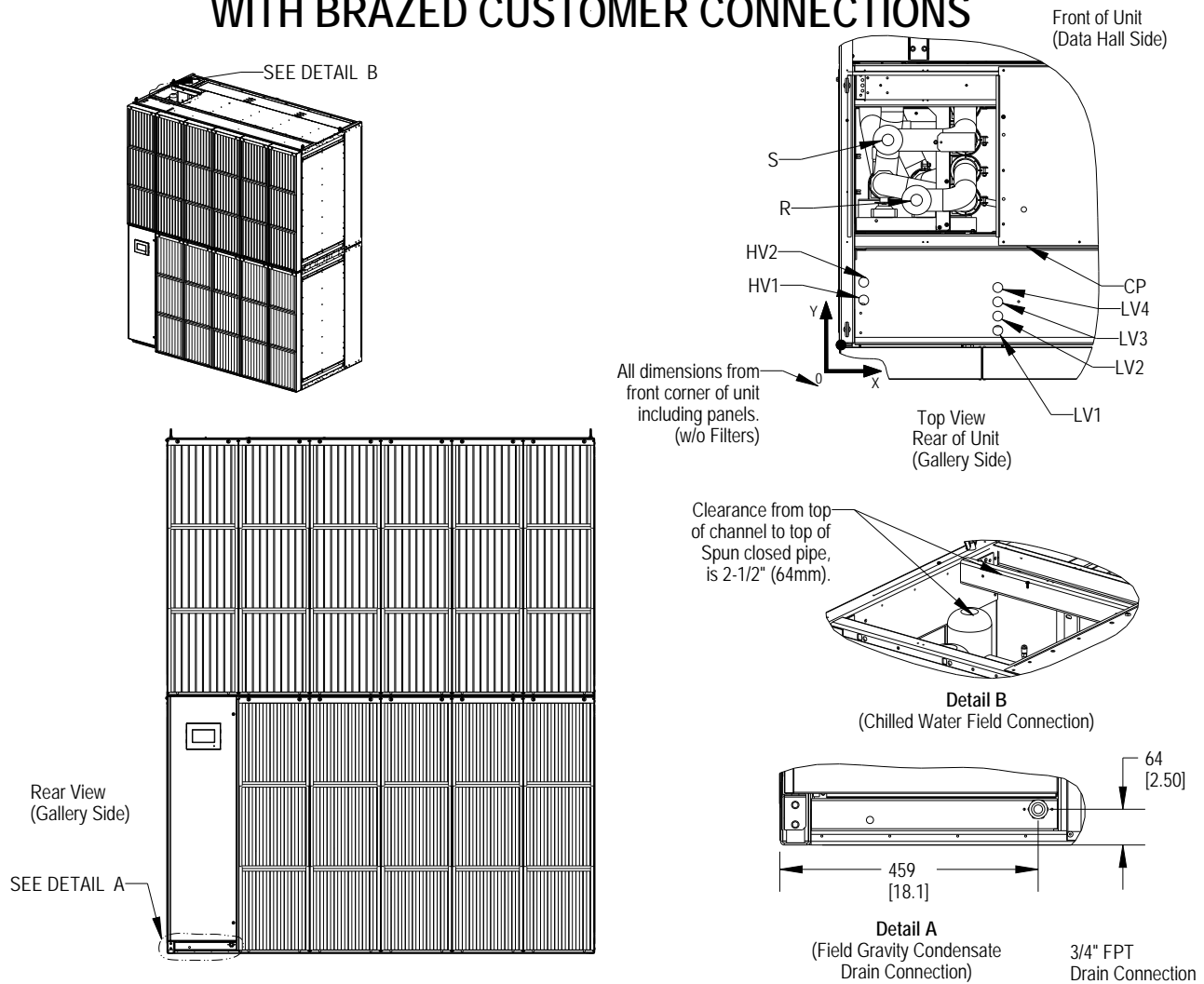

Connection	Description	X mm (in.)	Y mm (in.)	Connection Size Opening in.
R	Return Pipe Connection	274 (10.8)	513 (20.2)	4" O.D. CU
S	Supply Pipe Connection	173 (6.8)	726 (28.6)	
LV1	Electrical Connection (Low Volt)	564 (22.2)	51 (2.0)	1-3/8
LV2			102 (4.0)	
LV3			152 (6.0)	
LV4			203 (8.0)	
HV1	Electrical Connection (High Volt)	86 (3.4)	157 (6.2)	1-3/8
HV2			221 (8.7)	
CP	Condensate Pump Connection	655 (25.8)	480 (18.9)	1/2" O.D. CU

Notes:

- Drawing not to scale. All dimensions from left corner on Gallery Side and have a tolerance of $\pm 1/2"$ (13mm).
- The factory unit does not contain a trap. The drain must comply with all local codes. Select appropriate drain system materials. Field pitch Condensate Drain line a minimum 1/8" (3mm) per 12" (305mm).
- Piping connection can be made at the top of the unit.

PRIMARY CONNECTION LOCATIONS WITH BRAZED CUSTOMER CONNECTIONS CHILLED WATER COIL DRAIN DETAIL

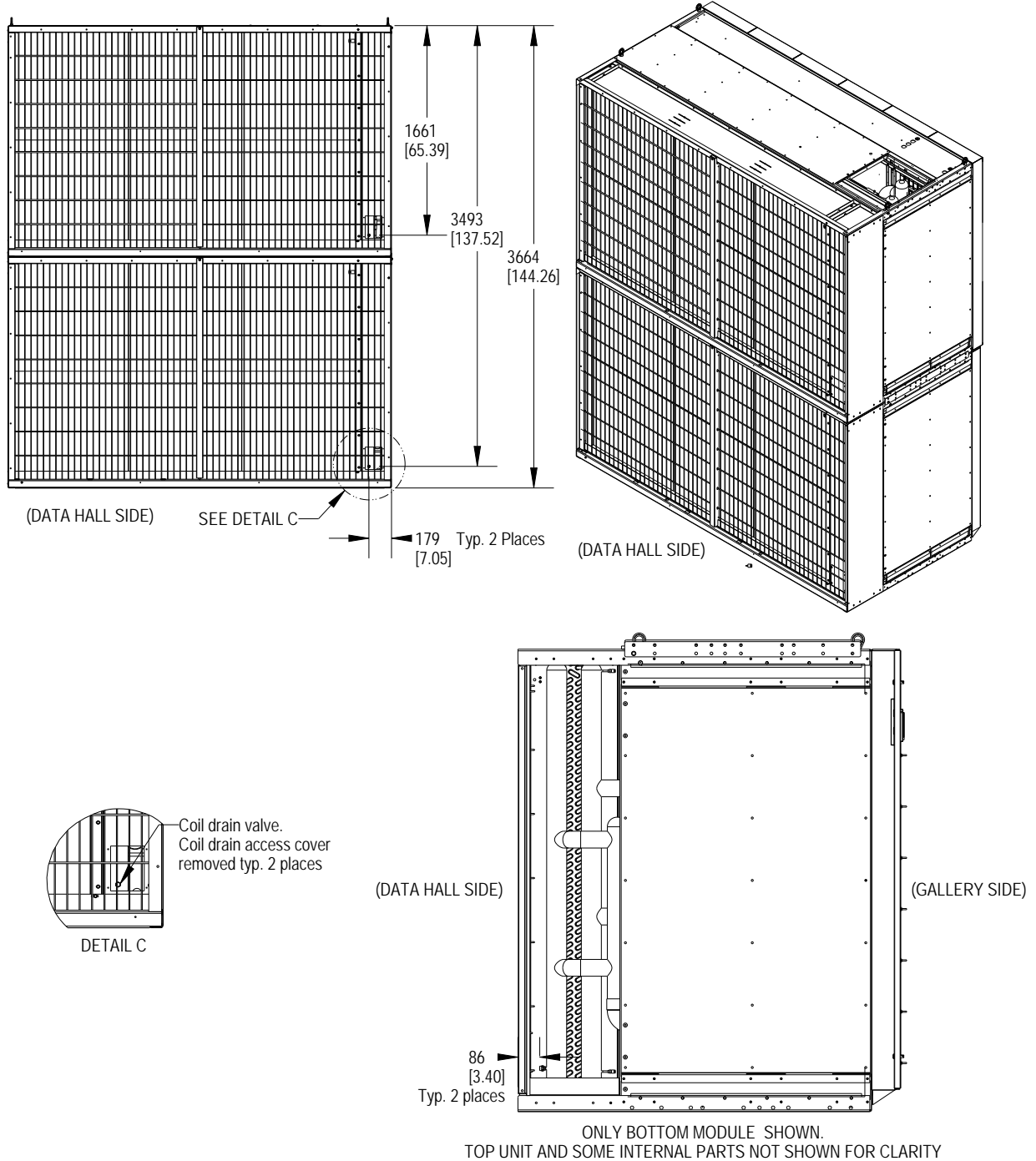

Notes:
1. Drawing not to scale.

PRIMARY CONNECTION LOCATIONS WITH FLANGED CUSTOMER CONNECTIONS

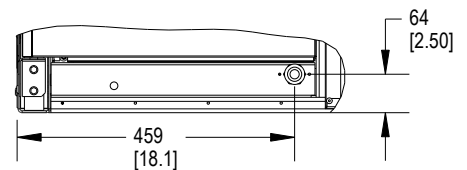
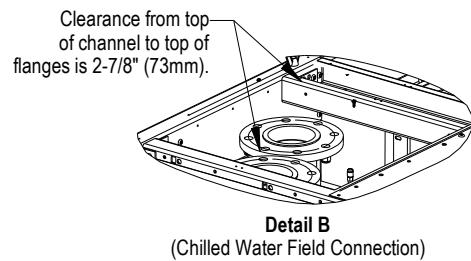
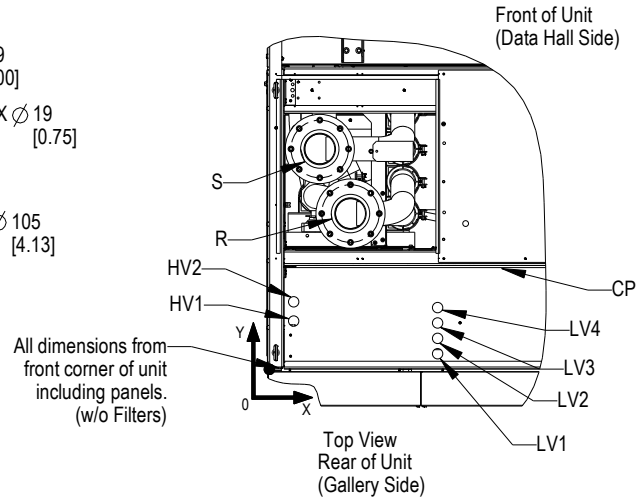
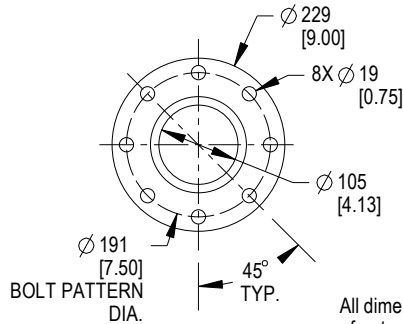
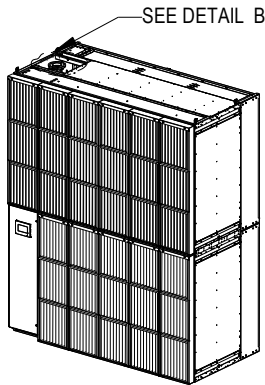

Detail A
(Field Gravity Condensate Drain Connection)

3/4" FPT Drain Connection

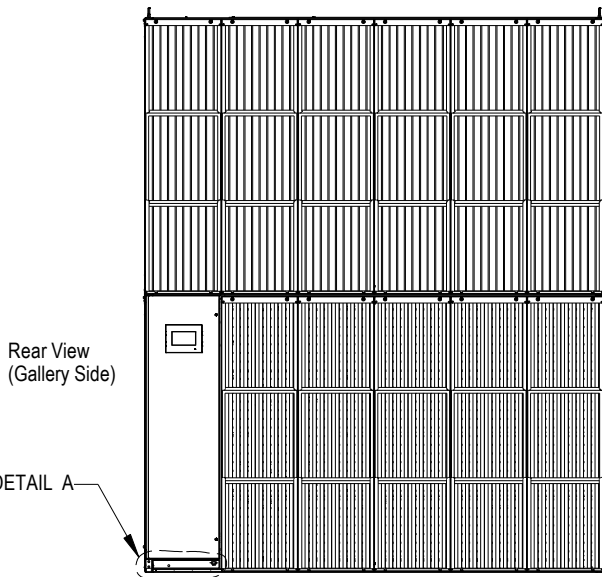

Connection	Description	X mm (in.)	Y mm (in.)	Connection Size Opening in.
R	Return Pipe Connection	274 (10.8)	513 (20.2)	4" WF-150 Style Flat Flange
S	Supply Pipe Connection	175 (6.9)	727 (28.6)	
LV1	Electrical Connection (Low Volt)	564 (22.2)	51 (2.0)	1-3/8
LV2			102 (4.0)	
LV3			152 (6.0)	
LV4			203 (8.0)	
HV1	Electrical Connection (High Volt)	86 (3.4)	157 (6.2)	
HV2			221 (8.7)	
CP	Condensate Pump Connection	655 (25.8)	480 (18.9)	1/2" O.D. CU

Notes:

- Drawing not to scale. All dimensions from left corner on Gallery Side and **have a tolerance of $\pm 1/2"$ (13mm).**
- The factory unit does not contain a trap. The drain must comply with all local codes. Select appropriate drain system materials. Field pitch Condensate Drain line a minimum 1/8" (3mm) per 12" (305mm).
- Piping connection can be made at the top of the unit.

**PRIMARY CONNECTION LOCATIONS
WITH FLANGED CUSTOMER CONNECTIONS
CHILLED WATER COIL DRAIN DETAIL**

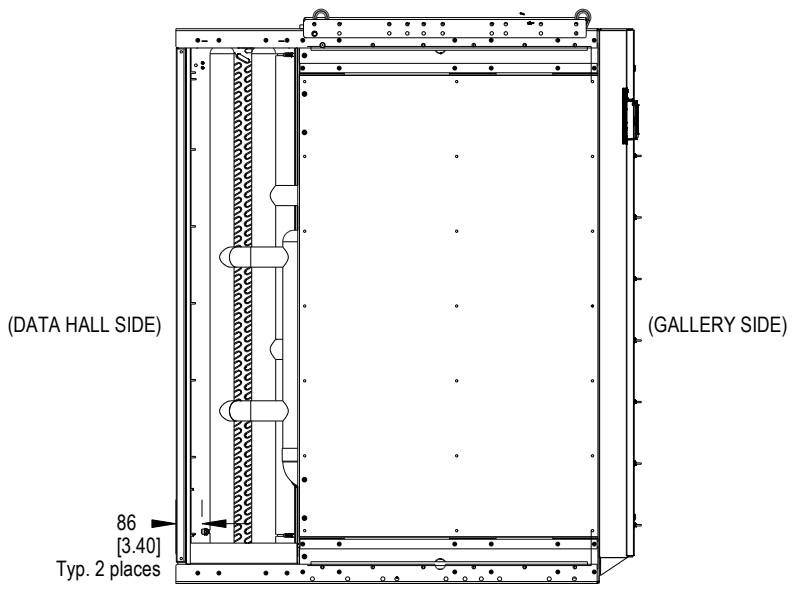
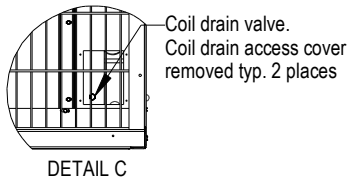
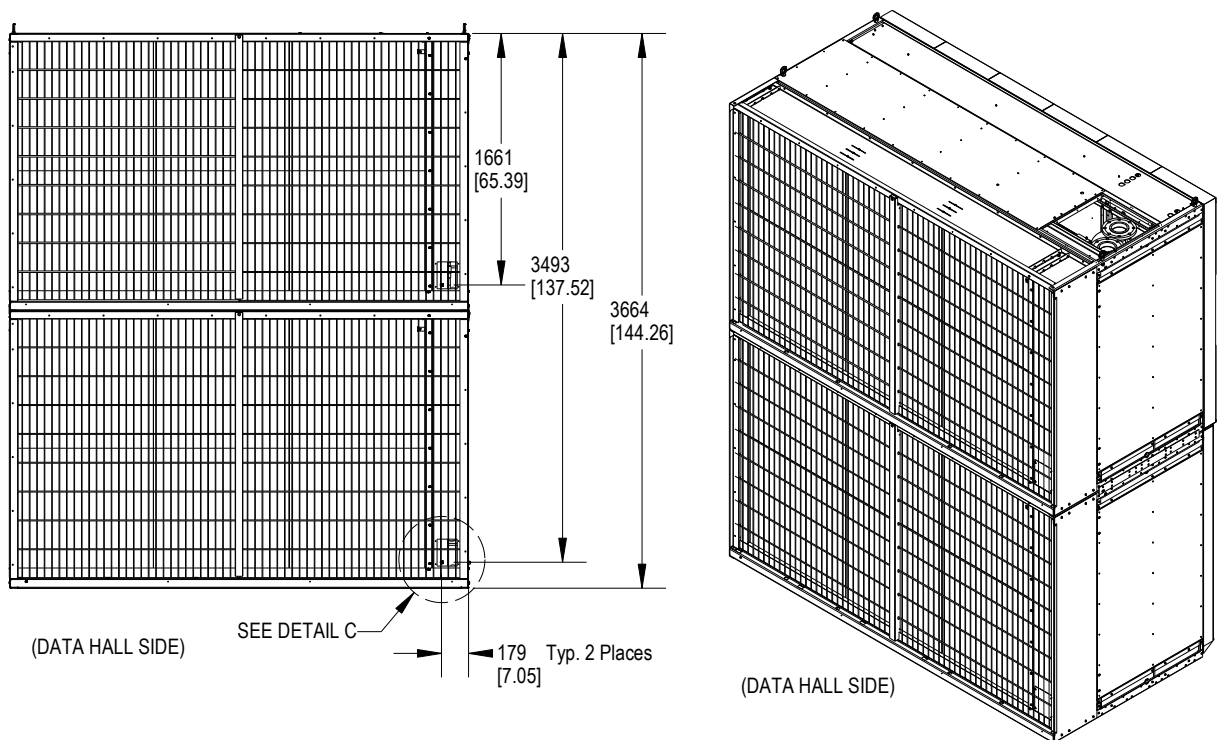

ONLY BOTTOM MODULE SHOWN.
TOP UNIT AND SOME INTERNAL PARTS NOT SHOWN FOR CLARITY

Notes:
1. Drawing not to scale.

AUTOMATIC TRANSFER SWITCH CONTROL MODULE

OVERVIEW OF LOVATO ATS, MODELS ATL610 & ATL800

Liebert Thermal Management units equipped with the optional Lovato ATS (automatic transfer switch) control, will automatically switch over to a secondary power source upon loss of primary power. It will also return to the primary power source when it is determined it is available.

When units are equipped with the optional Capacitive Buffer feature, it will not only keep the Liebert® iCOM™ control powered (minimum of 3 minutes) during a loss of power, but will also keep the ATS electronics powered when neither the primary or secondary source are available, allowing for a quick unit response when power is restored.

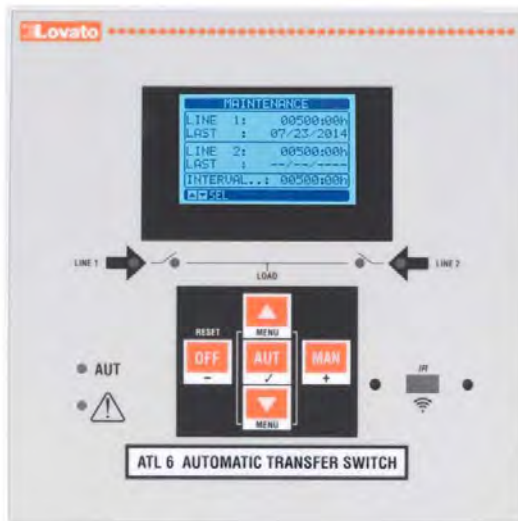

ATL610 (Units up to 460V)

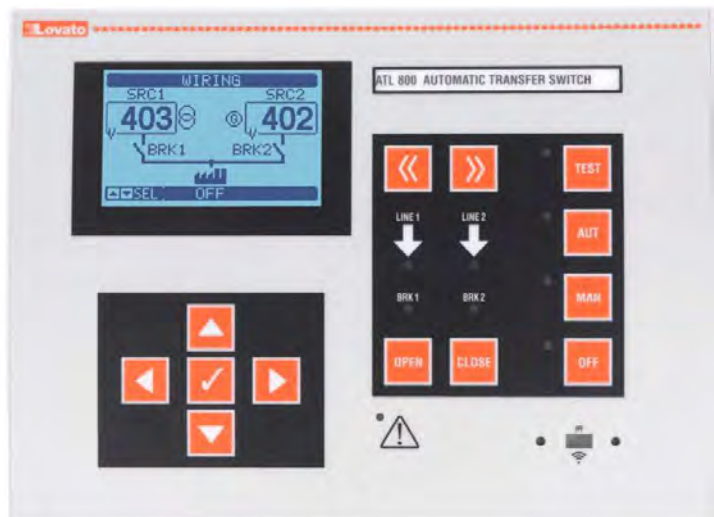

ATL800 (575V Units)

Lovato ATS, model ATL610 (or ATL800) shown in images above, will be located within the cabinet of the units.



VERTIV™

AUTOMATIC TRANSFER SWITCH

CONTROL MODULE

KEY CAPABILITIES OF LOVATO ATS, MODELS ATL610 & ATL800

The Lovato ATS, model ATL610 (or ATL800), will be the primary unit level device for switching between power sources. This control will be capable of the following features:

- Determine if power is available in both primary and secondary sources
- Allow for selection of which source is primary and which is secondary
- Ability to automatically switch from primary to secondary source, in the event of primary power loss
- Ability to automatically switch secondary to primary source when primary power returns
- Visible indication of available power sources
- Visible indication of power source that is currently active

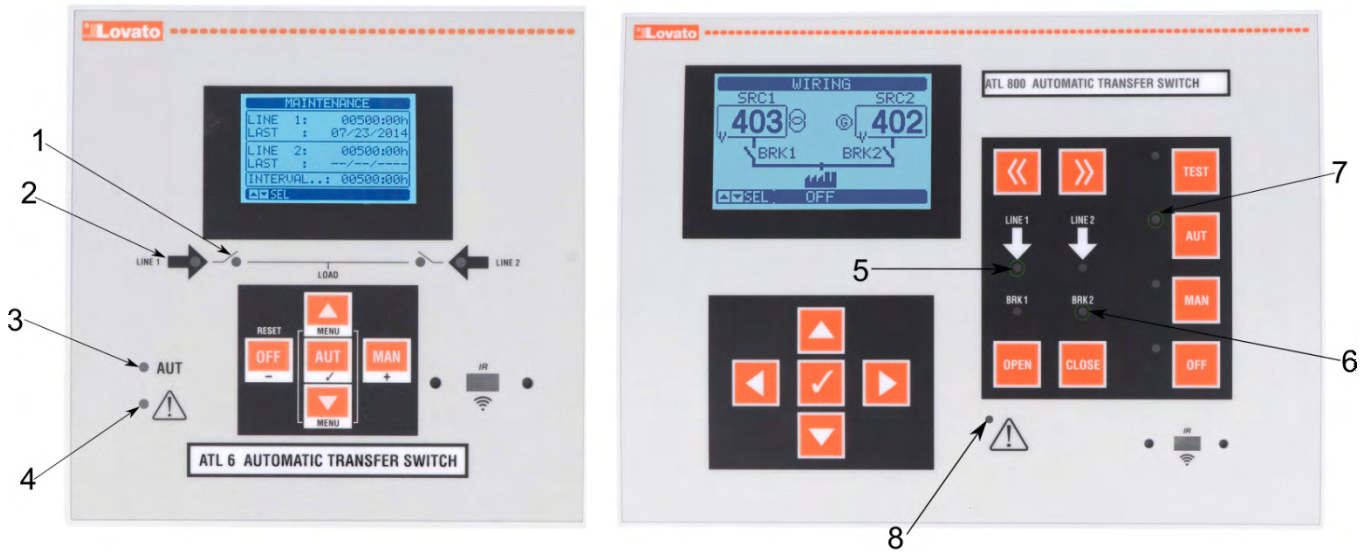

Item #	Description for ATL610 Display	Item #	Description for ATL800 Display
1	LEDs indicate which source is active	5	LEDs indicate if a source is available
2	LEDs indicate if a source is available	6	LEDs indicate which source is active
3	Controller is in automatic mode	7	Controller is in automatic mode
4	Alarm is present	8	Alarm is present

ATL610 (Units up to 460V)

ATL800 (575V Units)



VERTIV™

AUTOMATIC TRANSFER SWITCH

CONTROL MODULE

INTERACTION OF LOVATO ATS WITH LIEBERT® iCOM™ CONTROL

The Liebert® iCOM™ control will pull key information from the Lovato ATS, allowing for easy interpretation of the current operation without needing to open the unit's front panel, potentially interrupting operation.

*Identification of current power source and power source availability

*Available via PA2.06.54.04R or greater



Power source availability

- GREEN circle w/ check mark = power source available
- RED circle w/ cross = power source not available

Power Source A/B utilization

- ORANGE highlighted & underlined power source title = current power source being utilized.



VERTIV™

AUTOMATIC TRANSFER SWITCH

CONTROL MODULE

KEY PARAMETERS OF LOVATO ATS, MODELS ATL610 & ATL800

There are multiple key parameters that are factory set by Vertiv to recommended values. Please consult a Vertiv factory technician before making any changes to these parameters.

- Priority power source selection (default = Source 1)
- Switching delay between power sources
 - if secondary power source is present at time of primary failure, delay is up to 11s (default, adjustable via multiple parameters)
 - if secondary power source is **NOT** present at time of primary failure, delay is 10s (default, adjustable) after secondary power source is available
- Unit would be removed from active power source in following conditions:
 - Voltage Limit: If voltage is outside of a set limit for a set period (default = 5s)
 - Min Voltage Limit = 85% (default) of nominal
 - Max Voltage Limit = 115% (default) of nominal
 - Voltage Imbalance: If voltage imbalance (asymmetry) is greater than 15% (default) for a set period (default = 5s)
 - Phase Loss: If a phase falls below 70% (default) of nominal for a set period (default = 0.1s)
 - Frequency Limit: If frequency is outside of a set limit for a set period (default = 3s)
 - Min Freq Limit = 95% (default)
 - Max Frequency Limit = 105% (default)

Please note that not all parameters are applicable to Vertiv equipment operation. Consult a Vertiv factory technician before making any changes to these parameters.

AUTOMATIC TRANSFER SWITCH CONTROL MODULE

MONITORING FUNCTIONS OF LOVATO ATS, MODELS ATL610 & ATL800

The voltage and frequency information from the ATS can be displayed on the Liebert® iCOM™ user interface, as shown in the below image. Further information is available via BMS monitoring through the Liebert® iCOM™ Unity Card / Embedded Unity (BACnet MSTP, BACnet IP, Modbus TCP/IP, Modbus RTU, SNMP v2, v3). The items are outlined in the table on the following page.

ATS voltage & frequency summary page

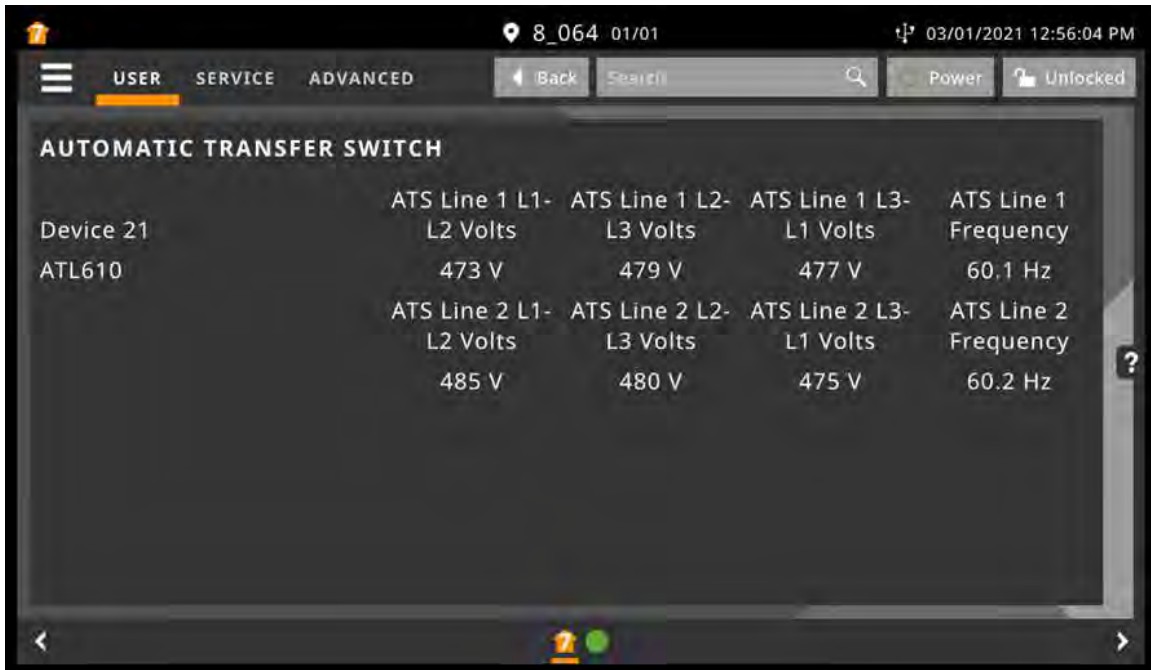

Device 21	ATS Line 1 L1- L2 Volts	ATS Line 1 L2- L3 Volts	ATS Line 1 L3- L1 Volts	ATS Line 1 Frequency
ATL610	473 V	479 V	477 V	60.1 Hz
Device 21	ATS Line 2 L1- L2 Volts	ATS Line 2 L2- L3 Volts	ATS Line 2 L3- L1 Volts	ATS Line 2 Frequency
ATL610	485 V	480 V	475 V	60.2 Hz



AUTOMATIC TRANSFER SWITCH

CONTROL MODULE

MONITORING POINTS

The below ATS specific points can be monitored through a BMS system. Alarm codes at the ATS panel will not match the BMS alarm but can be cross referenced in this chart. Please note that these points are read only.

Lovato Code (at ATS)	Vertiv Alarm (BMS)	Description
ATS_EvLdTO	ATS Load Not Powered Timeout	Unit has not been powered after preset delay (default = 60s).
ATS1_L1L2	Power Source: L1-L2 voltage	Voltage reading phase L1-L2
ATS1_L2L3	Power Source: L2-L3 voltage	Voltage reading phase L2-L3
ATS1_L3L1	Power Source: L3-L1 voltage	Voltage reading phase L3-L1
ATS1_Freq	Power Source: Line Frequency	Measured frequency, per source.
ATS1_BrkOp	Power Source: Breaker Operation Count	Available to be turned on by customer, would indicate number of operations per source.
ATS1VAIOk	Power Source: All status are okay	All parameters are within limits, per source.
ATS1VLo	Power Source: Voltage Is Too Low	Voltage on active source is below acceptable range.
ATS1VHi	Power Source: Voltage Is Too High	Voltage on active source is above acceptable range.
ATS1VAsymm	Power Source: Voltages Are Asymmetric	Voltages imbalance alarm
ATS1VPhsLs	Power Source: Voltage Phase Loss	Indicates one of the phases voltage has dropped below 70% nominal.
ATS2VPhsSq	Power Source: Phase Sequence Issue	Indicates the incoming power wasn't wired per the phase sequence configured (L1-L2-L3).
ATS1VFrqLo	Power Source: Frequency Is Too Low	Frequency on active source is below acceptable range.
ATS1VFrqHi	Power Source: Frequency Is Too High	Frequency on active source is above acceptable range.
ATS2BClsd	Power Source: Breaker is closed	ATS is receiving feedback that the indicated contactor as closed.
ATS2BCClsd	Power Source: Breaker command status closed	ATS is directing the indicated contactor to close.
ATS1EvBTim	Power Source: Breaker Timeout Issue	The indicated changeover device did not complete the closing operation within the max set time.
ATS1EvHrsS	Power Source: Line Operating Hour Exceeded	Available to be turned on by customer, would indicate number of hours in operation per source



AUTOMATIC TRANSFER SWITCH

CONTROL MODULE

CHANGE OVER CIRCUIT SEQUENCE OF OPERATIONS

Source 1 is out of range

- 1) Source 1 exceeds one or more limits of voltage, frequency, phase, or voltage symmetry.
- 2) A delay timer will begin to count. The amount of time depends on which Source 1 parameter is out of spec, and the value saved in the following parameters. The parameters below are the delays for each condition.

Description	Default	Parameter	
		ATL610	ATL800
voltage below the minimum limit	5s	P06.03	P09.01.03
voltage above the maximum limit	5s	P06.06	P09.01.06
phase failure	0.1s	P06.10	P09.01.10
voltage exceeds the asymmetry limits	5s	P06.12	P09.01.12
frequency exceeds the maximum limit	3s	P06.14	P09.01.14
frequency exceeds the minimum limit	5s	P06.16	P09.01.16

- 3) Once the delay timer is finished, the following events will occur.
 - a) the transfer controller will de-energize Source 1 contactor coil
 - b) the transfer controller will signal the unit is no longer being powered by Source 1
 - c) An auxiliary switch NO contact on Source 1's contactor will open, sending a signal to the transfer controller. This signal verifies that the load is not connected to Source 1.
 - d) The NC contacts of the same auxiliary switch will close to allow the coil of the Source 2 contactor to be energized. The Source 2 contactor coil is not energized at this time.
- 4) Once the transfer controller output has opened, a delay timer will begin using the value entered under parameter P05.03 (ATL610) or P07.01.02 (ATL800), default = 6s. **This value should not be decreased without consent from Vertiv.**
- 5) A presence delay is used to determine if Source 2 is a valid source. This delay will start as soon as Source 2 is available. The presence delay is based on the value entered in parameter P07.07 (ATL610) or P09.02.07 (ATL800), default = 10s. If Source 2 is available before Source 1 fails, it is possible that the delay will already be satisfied at the time Source 1 fails. If this is a manual transfer to Source 2 and Source 1 is still available, the presence delay will refer to the value in parameter P07.08 (ATL610) or P09.02.08 (ATL800), default = 60s.
- 6) When the timer in both step 4 and 5 are finished,
 - a) the transfer controller will energize the Source 2 contactor
 - b) An auxiliary switch NO contact on Source 2's contactor will close, sending a signal to the transfer controller. This signal verifies that the load is connected to Source 2.
 - c) The NC contacts of the same auxiliary switch will open to prevent the coil of Source 1 contactor from energizing.
 - d) the transfer controller will signal the unit is being powered by Source 2

Transfer back to Source 1 when Source 2 is present

- 1) When Source 1 has reached acceptable levels, a presence delay will start. The presence delay is based on the value entered in parameter P06.08 (ATL610) or P09.01.08 (ATL800), default = 60s.
- 2) Once this timer is finished,
 - a) the transfer controller will de-energize Source 2 contactor coil
 - b) An auxiliary switch NO contact on Source 2's contactor will open, sending a signal to the transfer controller. This signal verifies that the load is not connected to Source 2.
 - c) The NC contacts of the same auxiliary switch will close to allow the coil of the Source 1 contactor to be energized. The Source 1 contactor coil is not energized at this time.
 - d) the transfer controller will signal the unit is no longer being powered by Source 2
- 3) A delay timer starts using the value in parameter P05.04 (ATL610) or P07.02.02 (ATL800), default = 6s. **This value should not be decreased without consent from Vertiv.**
- 4) When the timer in step 3 is finished,
 - a) the transfer controller will energize the Source 1 contactor
 - b) An auxiliary switch NO contact on Source 1's contactor will close, sending a signal the transfer controller. This signal verifies that the load is connected to Source 1.
 - c) The NC contacts of the same auxiliary switch will open to prevent the coil of Source 2 contactor from energizing.
 - d) the transfer controller will signal the unit is being powered by Source 1

AUTOMATIC TRANSFER SWITCH

CONTROL MODULE

CHANGE OVER CIRCUIT SEQUENCE OF OPERATIONS

Source 2 is out of range when unit is powered by Source 2

- 1) Source 2 exceeds one or more limits of voltage, frequency, phase, or voltage symmetry.
- 2) A delay timer will begin to count. The amount of time depends on which Source 2 parameter is out of spec, and the value saved in the following parameters. The parameters below are the delays for each condition.

Description	Default	Parameter	
		ATL610	ATL800
voltage below the minimum limit	5s	P07.03	P09.02.03
voltage above the maximum limit	5s	P07.06	P09.02.06
phase failure	0.1s	P07.10	P09.02.10
voltage exceeds the asymmetry limits	5s	P07.12	P09.02.12
frequency exceeds the maximum limit	3s	P07.14	P09.02.14
frequency exceeds the minimum limit	5s	P07.16	P09.02.16

- 3) Once the delay timer is finished, the following events will occur.
 - a) the transfer controller will de-energize Source 2 contactor coil
 - b) the transfer controller will signal the unit is no longer being powered by Source 2
 - c) An auxiliary switch NO contact on Source 2's contactor will open, sending a signal to the transfer controller. This signal verifies that the load is not connected to Source 2.
 - d) The NC contacts of the same auxiliary switch will close to allow the coil of Source 1 contactor to be energized. The Source 1 contactor coil is not energized at this time.
- 4) Once the transfer controller output has opened, a delay timer will begin using the value entered under parameter P05.04 (ATL610) or P07.02.02 (ATL800), default = 6s. **This value should not be decreased without consent from Vertiv.**
- 5) A presence delay is used to determine if Source 1 is a valid source. This delay will start as soon as Source 1 is available. The presence delay is based on the value entered in parameter P06.07 (ATL610) or P09.01.07 (ATL800), default = 10s. If Source 1 is available before Source 2 fails, it is possible that the delay will already be satisfied at the time Source 2 fails. If this is a manual transfer to Source 1 and Source 2 is still available, the presence delay will refer to the value in parameter P06.08 (ATL610) or P09.01.08 (ATL800), default = 60s.
- 6) When the timer in both step 4 and 5 are finished,
 - a) the transfer controller will energize the Source 1 contactor
 - b) An auxiliary switch NO contact on Source 1's contactor will close, sending a signal to the transfer controller. This signal verifies that the load is connected to Source 1.
 - c) The NC contacts of the same auxiliary switch will open to prevent the coil of Source 2 contactor from energizing.
 - d) the transfer controller will signal the unit is being powered by Source 1

Transfer when Source 1 and Source 2 fails

- 1) If both Source 1 and Source 2 fail and are restored, the transfer controller will transfer the load to the preferred Source defined in parameter P05.02 (ATL610) or P06.01.02/P06.02.02 (ATL800), default = 1.



AUTOMATIC TRANSFER SWITCH

CONTROL MODULE

CHANGE OVER CIRCUIT SEQUENCE OF OPERATIONS

Transfer Controller Terminal Labels – ATL610

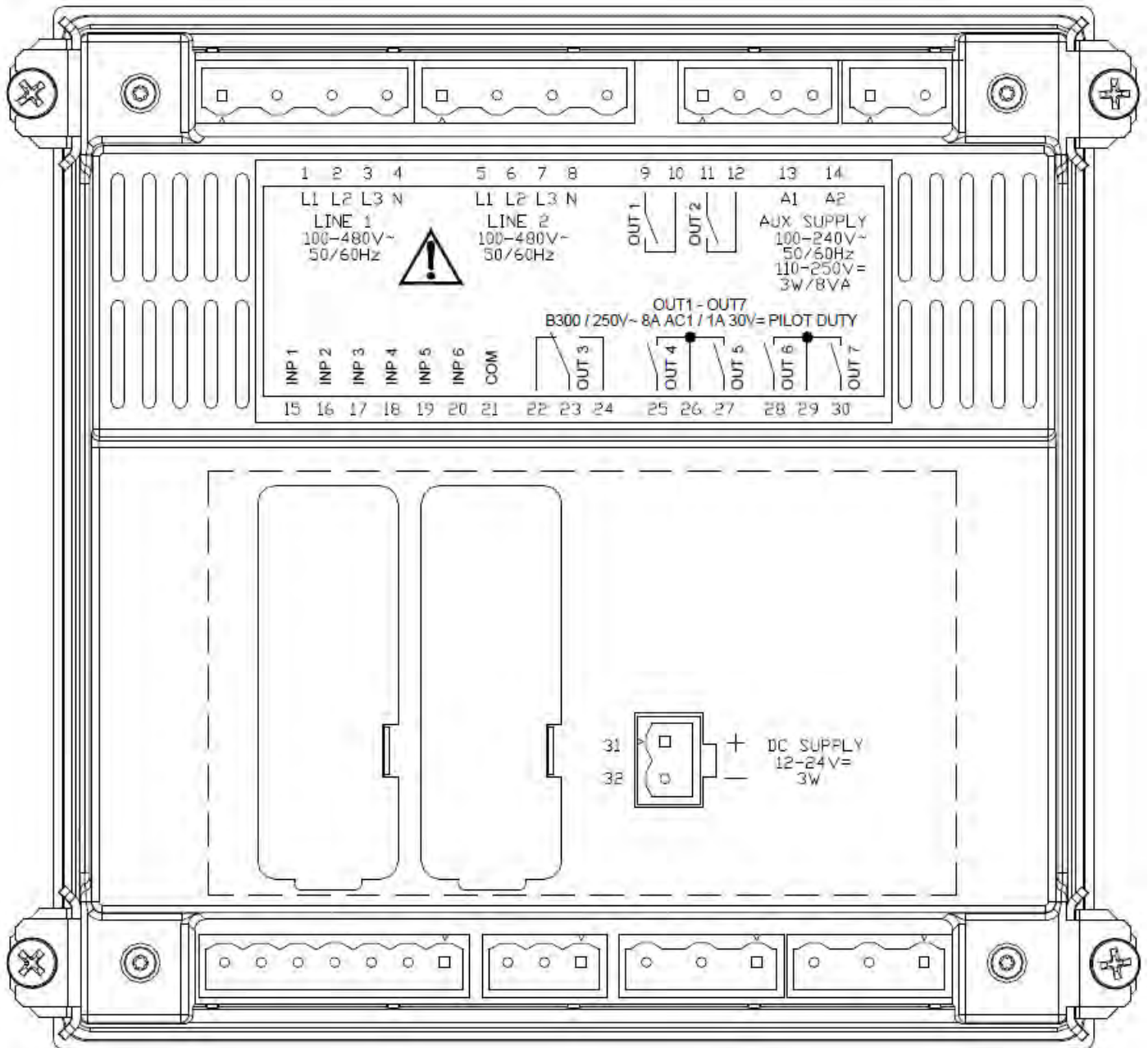



VERTIV

AUTOMATIC TRANSFER SWITCH

CONTROL MODULE

CHANGE OVER CIRCUIT SEQUENCE OF OPERATIONS

Transfer Controller Terminal Labels – ATL800

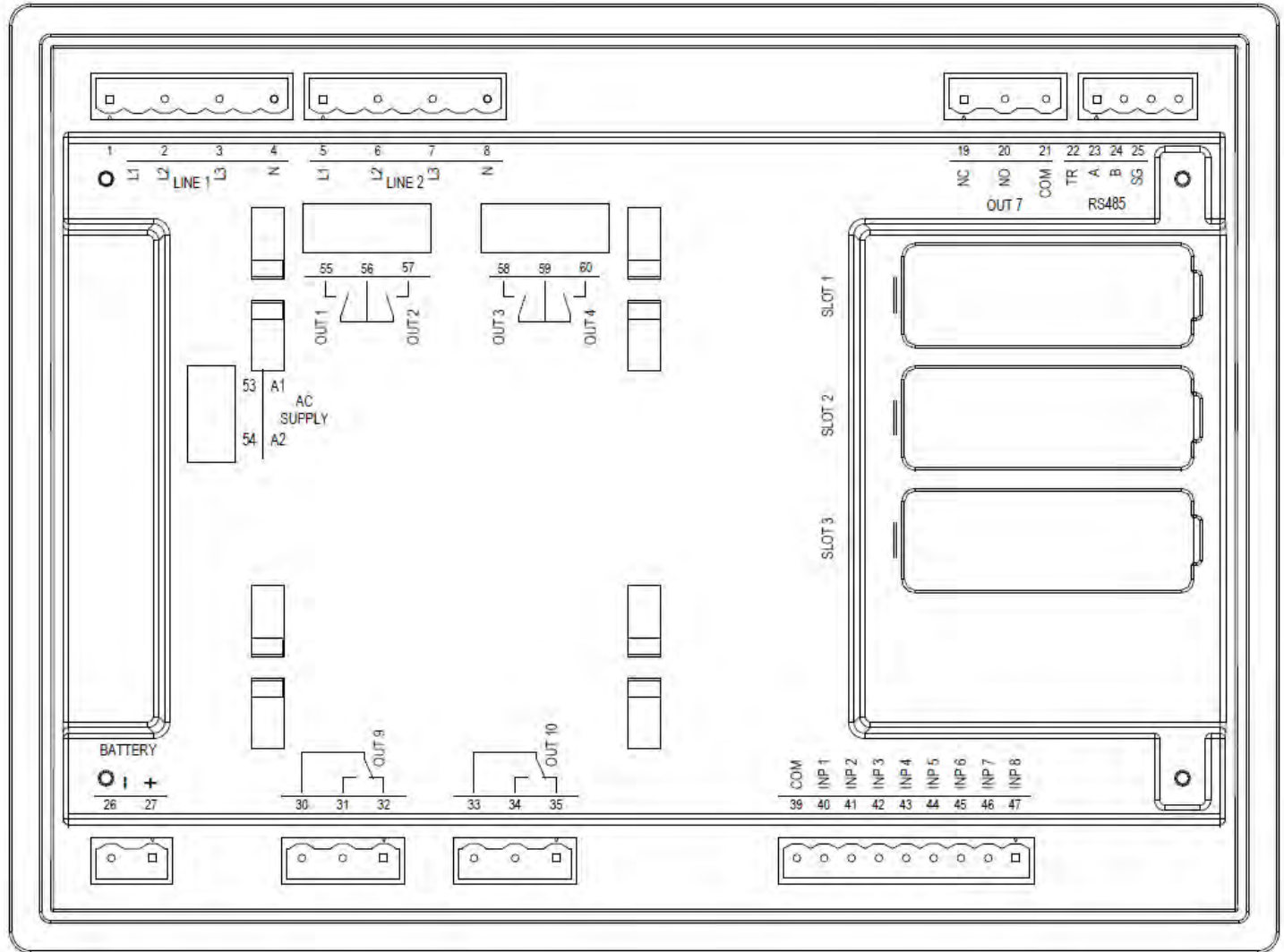



LIEBERT® CWA

THD MITIGATION CA60 STANDARD FAN

IEEE Std 519-2014 defines the maximum voltage distortion limits allowed to be reflected onto the utility distribution system at the point of common coupling (PCC). It is a guideline meant to minimize the effects of electrical pollution created by one utility customer from affecting a different customer.

The guideline requires total voltage harmonic distortion (THD) conform to the limits shown in Table 1.

Table 1 - Voltage distortion limits

Bus voltage V at PCC	Individual Harmonic (%)	Total harmonic distortion THD (%)
$V \leq 1.0 \text{ kV}^b$	5.0	8.0
$1 \text{ kV} < V \leq 69 \text{ kV}$	3.0	5.0
$69 \text{ kV} < V \leq 161 \text{ kV}$	1.5	2.5
$161 \text{ kV} < V$	1.0	1.5 ^a

^aHigh-voltage systems can have up to 2.0% THD where the cause is an HVDC terminal whose effects will have attenuated at points in the network where future users may be connected.

^bLiebert® CWA units fall under the limits for $V \leq 1.0 \text{ kV}$

The individual harmonic current distortion and total current demand distortion (TDD) conform to the limits shown in Table 2.

Table 2 - Current distortion limits for systems rated 120 V through 69 kV

Maximum harmonic current distortion in percent of I_L						
Individual harmonic order (odd harmonics) ^{a,b}						
I_{sc} / I_L	$3 \leq h < 11$	$11 \leq h < 17$	$17 \leq h < 23$	$23 \leq h < 135$	$35 \leq h < 50$	TDD
$< 20^c$	4.0	2.0	1.5	0.6	0.3	5.0
$20 < 50$	7.0	3.5	2.5	1.0	0.5	8.0
$50 < 100$	10.0	4.5	4.0	1.5	0.7	12.0
$100 < 1000^d$	12.0	5.5	5.0	2.0	1.0	15.0
> 1000	15.0	7.0	6.0	2.5	1.4	20.0

^aEven harmonics are limited to 25% of the odd harmonic limits above.

^bCurrent distortions that result in a dc offset, e.g., half-wave converters, are not allowed.

^cAll power generation equipment is limited to these values of current distortion, regardless of actual I_{sc} / I_L where

I_{sc} = maximum short-circuit current at PCC (determined by building short circuit analysis)

I_L = maximum demand load current (fundamental frequency component)

at the PCC under normal load operating conditions

^dLiebert® CWA units typically fall under the limits for $100 < 1000$, assuming $I_{sc} \geq 2,000$ amps

It is **NOT** a guideline for individual connected loads, but a guideline for a total building or plant. Many apply the voltage distortion criteria to all substations, and apply the current distortion criteria exclusively to the utility metering point.

Typically, if the variable speed fan load is less than 10% of the current capacity at the point of common coupling (PCC), your installation will meet IEEE-519 guidelines. In this case you should have no interference issues with other electrical equipment. Typically, the worst case PCC is the emergency backup generator plant but could be the transformer which powers the cooling load. If the PCC is a UPS unit, consult your UPS supplier for recommendations. For customers who have variable speed loads that exceed this rule of thumb, it may be necessary to minimize the harmonic impact these variable speed loads have on the system voltage. In these instances, an undesirable effect is a difficulty in switching from generator supply back to utility supply. The purpose of the Liebert® CWA THD mitigation device is to cancel current harmonics generated by the variable frequency drive. This device will not improve harmonics caused by other systems on the power network.



LIEBERT® CWA

THD MITIGATION CA60 STANDARD FAN

Below are the Total Voltage Distortion levels as measured on a single CA60 unit with standard fans. This data is typical of what can be expected in the field. Values may vary depending on operating conditions.

WARNING: A passive harmonic filter raises the voltage to the fan by 20-30V. This difference requires that the input voltage be limited to +5%, -10% on 460V and 575V units. If the input voltage is above +5% of the rated voltage, disconnect the capacitor contactor coil from the circuit.

Typical Total Voltage Distortion for CA60 with Standard Fans at 460 Volts:

Voltage Harmonic List — 100% Fan Speed						
Without Mitigation Device						
Order	L1		L2		L3	
	Volts	% Distortion	Volts	% Distortion	Volts	% Distortion
1	494.49		493.61		492.30	
5	1.80	0.36%	2.55	0.52%	1.83	0.37%
7	3.31	0.67%	5.09	1.03%	5.22	1.06%
11	4.01	0.81%	4.16	0.84%	3.42	0.69%
13	3.66	0.74%	2.73	0.55%	3.10	0.63%
17	1.89	0.38%	1.57	0.32%	1.82	0.37%
Total THD (%)	2.28%		2.31%		2.21%	
With Mitigation Device						
Order	L1		L2		L3	
	Volts	% Distortion	Volts	% Distortion	Volts	% Distortion
1	476.32		473.33		475.26	
5	4.19	0.88%	4.36	0.92%	4.08	0.86%
7	4.95	1.04%	4.82	1.02%	5.22	1.10%
11	2.17	0.45%	1.78	0.38%	2.00	0.42%
13	3.14	0.66%	2.46	0.52%	2.62	0.55%
17	1.27	0.27%	1.26	0.27%	1.07	0.22%
Total THD (%)	2.17%		2.07%		1.99%	

Voltage Harmonic List — 50% Fan Speed						
Without Mitigation Device						
Order	L1		L2		L3	
	Volts	% Distortion	Volts	% Distortion	Volts	% Distortion
1	494.79		493.84		492.87	
5	1.33	0.27%	2.02	0.41%	1.20	0.24%
7	2.06	0.42%	4.17	0.84%	3.61	0.73%
11	2.63	0.53%	2.55	0.52%	2.31	0.47%
13	2.88	0.58%	1.98	0.40%	2.39	0.49%
17	0.99	0.20%	1.23	0.25%	1.10	0.22%
Total THD (%)	2.03%		2.05%		1.95%	
With Mitigation Device						
Order	L1		L2		L3	
	Volts	% Distortion	Volts	% Distortion	Volts	% Distortion
1	477.13		474.38		474.43	
5	3.36	0.70%	2.98	0.63%	2.95	0.62%
7	4.11	0.86%	3.85	0.81%	3.88	0.82%
11	0.99	0.21%	1.20	0.25%	1.65	0.35%
13	1.94	0.41%	1.06	0.22%	1.51	0.32%
17	0.60	0.13%	0.34	0.07%	0.47	0.10%
Total THD (%)	1.88%		1.72%		1.59%	



LIEBERT® CWA

THD MITIGATION CA60 STANDARD FAN

Below are the Total Current Distortion levels as measured on a single CA60 unit with standard fans. This data is typical of what can be expected in the field. Values may vary depending on operating conditions.

Typical Total Current Distortion for CA60 with Standard Fans at 460 Volts:

Current Harmonic List — 100% Fan Speed						
Without Mitigation Device						
Order	L1		L2		L3	
	amps	% Distortion	amps	% Distortion	amps	% Distortion
1	16.99		16.86		16.97	
5	3.92	23.08%	4.06	24.08%	4.02	23.71%
7	3.78	22.26%	3.60	21.35%	3.70	21.83%
11	3.18	18.74%	3.35	19.85%	3.15	18.57%
13	1.75	10.31%	1.73	10.27%	1.70	10.00%
17	1.84	10.83%	1.89	11.23%	1.96	11.52%
Total THD (%)	44.07%		44.24%		43.93%	
With Mitigation Device						
Order	L1		L2		L3	
	amps	% Distortion	amps	% Distortion	amps	% Distortion
1	16.70		16.53		16.79	
5	0.26	1.55%	0.20	1.19%	0.24	1.43%
7	0.50	2.97%	0.41	2.49%	0.42	2.51%
11	0.40	2.41%	0.40	2.42%	0.39	2.33%
13	0.21	1.26%	0.18	1.10%	0.20	1.21%
17	0.02	0.15%	0.02	0.11%	0.02	0.13%
Total THD (%)	4.71%		3.98%		4.38%	

Current Harmonic List — 50% Fan Speed						
Without Mitigation Device						
Order	L1		L2		L3	
	amps	% Distortion	amps	% Distortion	amps	% Distortion
1	6.48		6.31		6.40	
5	3.25	50.21%	3.34	52.95%	3.24	50.54%
7	2.26	34.89%	2.11	33.43%	2.23	34.86%
11	1.82	28.08%	1.83	29.03%	1.70	26.57%
13	0.96	14.78%	1.12	17.72%	0.94	14.76%
17	1.34	20.73%	1.41	22.39%	1.35	21.13%
Total THD (%)	94.84%		95.93%		94.18%	
With Mitigation Device						
Order	L1		L2		L3	
	amps	% Distortion	amps	% Distortion	amps	% Distortion
1	6.09		6.00		5.99	
5	0.18	3.02%	0.16	2.66%	0.17	2.91%
7	0.29	4.72%	0.33	5.53%	0.31	5.18%
11	0.21	3.48%	0.19	3.25%	0.20	3.29%
13	0.07	1.08%	0.07	1.22%	0.07	1.14%
17	0.02	0.29%	0.02	0.36%	0.02	0.27%
Total THD (%)	7.20%		7.56%		7.47%	

NOTE: Values shown at 50% fan speed are for reference only. At low demand, THD values will have a lower impact on the system than at full load.



LIEBERT® CWA

THD MITIGATION CA60 HIGH AIRFLOW HIGH EFFICIENCY FAN

IEEE Std 519-2014 defines the maximum voltage distortion limits allowed to be reflected onto the utility distribution system at the point of common coupling (PCC). It is a guideline meant to minimize the effects of electrical pollution created by one utility customer from affecting a different customer.

The guideline requires total voltage harmonic distortion (THD) conform to the limits shown in Table 1.

Table 1 - Voltage distortion limits

Bus voltage V at PCC	Individual Harmonic (%)	Total harmonic distortion THD (%)
$V \leq 1.0 \text{ kV}^b$	5.0	8.0
$1 \text{ kV} < V \leq 69 \text{ kV}$	3.0	5.0
$69 \text{ kV} < V \leq 161 \text{ kV}$	1.5	2.5
$161 \text{ kV} < V$	1.0	1.5 ^a

^aHigh-voltage systems can have up to 2.0% THD where the cause is an HVDC terminal whose effects will have attenuated at points in the network where future users may be connected.

^bLiebert® CWA units fall under the limits for $V \leq 1.0 \text{ kV}$

The individual harmonic current distortion and total current demand distortion (TDD) conform to the limits shown in Table 2.

Table 2 - Current distortion limits for systems rated 120 V through 69 kV

Maximum harmonic current distortion in percent of I_L						
Individual harmonic order (odd harmonics) ^{a,b}						
I_{sc} / I_L	$3 \leq h < 11$	$11 \leq h < 17$	$17 \leq h < 23$	$23 \leq h < 135$	$35 \leq h < 50$	TDD
$< 20^c$	4.0	2.0	1.5	0.6	0.3	5.0
$20 < 50$	7.0	3.5	2.5	1.0	0.5	8.0
$50 < 100$	10.0	4.5	4.0	1.5	0.7	12.0
$100 < 1000^d$	12.0	5.5	5.0	2.0	1.0	15.0
> 1000	15.0	7.0	6.0	2.5	1.4	20.0

^aEven harmonics are limited to 25% of the odd harmonic limits above.

^bCurrent distortions that result in a dc offset, e.g., half-wave converters, are not allowed.

^cAll power generation equipment is limited to these values of current distortion, regardless of actual I_{sc} / I_L where

I_{sc} = maximum short-circuit current at PCC (determined by building short circuit analysis)

I_L = maximum demand load current (fundamental frequency component)

at the PCC under normal load operating conditions

^dLiebert® CWA units typically fall under the limits for $100 < 1000$, assuming $I_{sc} \geq 3,500$ amps

It is **NOT** a guideline for individual connected loads, but a guideline for a total building or plant. Many apply the voltage distortion criteria to all substations, and apply the current distortion criteria exclusively to the utility metering point.

Typically, if the variable speed fan load is less than 10% of the current capacity at the point of common coupling (PCC), your installation will meet IEEE-519 guidelines. In this case you should have no interference issues with other electrical equipment. Typically, the worst case PCC is the emergency backup generator plant but could be the transformer which powers the cooling load. If the PCC is a UPS unit, consult your UPS supplier for recommendations. For customers who have variable speed loads that exceed this rule of thumb, it may be necessary to minimize the harmonic impact these variable speed loads have on the system voltage. In these instances, an undesirable effect is a difficulty in switching from generator supply back to utility supply. The purpose of the Liebert® CWA THD mitigation device is to cancel current harmonics generated by the variable frequency drive. This device will not improve harmonics caused by other systems on the power network.



LIEBERT® CWA

THD MITIGATION CA60 HIGH AIRFLOW HIGH EFFICIENCY FAN

Below are the Total Voltage Distortion levels as measured on a single CA60 unit with high airflow, high efficiency fans. This data is typical of what can be expected in the field. Values may vary depending on operating conditions.

WARNING: A passive harmonic filter raises the voltage to the fan by 20-30V. This difference requires that the input voltage be limited to +5%, -10% on 460V and 575V units. If the input voltage is above +5% of the rated voltage, disconnect the capacitor contactor coil from the circuit.

Typical Total Voltage Distortion for CA60 with High Airflow, High Efficiency Fans at 460 Volts:

Voltage Harmonic List — 100% Fan Speed						
Without Mitigation Device						
Order	L1		L2		L3	
	Volts	% Distortion	Volts	% Distortion	Volts	% Distortion
1	475.85		474.21		473.43	
5	4.35	0.91%	4.15	0.87%	4.86	1.03%
7	7.51	1.58%	6.24	1.32%	6.54	1.38%
11	4.66	0.98%	4.62	0.97%	4.95	1.04%
13	1.82	0.38%	1.72	0.36%	2.27	0.48%
17	3.93	0.82%	4.11	0.87%	4.10	0.87%
Total THD (%)		2.81%	2.71%		2.76%	
With Mitigation Device						
Order	L1		L2		L3	
	Volts	% Distortion	Volts	% Distortion	Volts	% Distortion
1	473.94		473.88		473.31	
5	4.23	0.89%	3.67	0.78%	4.44	0.94%
7	6.17	1.30%	5.24	1.11%	5.18	1.10%
11	3.67	0.77%	3.64	0.77%	4.00	0.85%
13	0.78	0.17%	0.87	0.18%	1.08	0.23%
17	2.44	0.52%	2.50	0.53%	2.44	0.52%
Total THD (%)		2.47%	2.48%		2.37%	

Voltage Harmonic List — 50% Fan Speed						
Without Mitigation Device						
Order	L1		L2		L3	
	Volts	% Distortion	Volts	% Distortion	Volts	% Distortion
1	478.98		474.86		476.71	
5	3.14	0.66%	3.05	0.64%	3.67	0.77%
7	5.46	1.14%	4.18	0.88%	4.13	0.87%
11	1.56	0.33%	1.28	0.27%	1.64	0.34%
13	0.98	0.21%	0.76	0.16%	0.88	0.18%
17	0.29	0.06%	0.11	0.02%	0.20	0.04%
Total THD (%)		2.01%	1.91%		1.88%	
With Mitigation Device						
Order	L1		L2		L3	
	Volts	% Distortion	Volts	% Distortion	Volts	% Distortion
1	474.29		474.83		475.18	
5	2.67	0.56%	2.54	0.54%	3.25	0.68%
7	4.56	0.96%	3.61	0.76%	3.50	0.74%
11	1.78	0.38%	1.89	0.40%	2.20	0.46%
13	0.67	0.14%	0.52	0.11%	0.61	0.13%
17	0.59	0.12%	0.45	0.09%	0.55	0.11%
Total THD (%)		1.94%	2.01%		1.86%	



LIEBERT® CWA

THD MITIGATION CA60 HIGH AIRFLOW HIGH EFFICIENCY FAN

Below are the Total Current Distortion levels as measured on a single CA60 unit with high airflow, high efficiency fans. This data is typical of what can be expected in the field. Values may vary depending on operating conditions.

Typical Total Current Distortion for CA60 with High Airflow, High Efficiency Fans at 460 Volts:

Current Harmonic List — 100% Fan Speed						
Without Mitigation Device						
Order	L1		L2		L3	
	amps	% Distortion	amps	% Distortion	amps	% Distortion
1	24.77		24.57		24.84	
5	6.09	24.59%	37.43	24.90%	6.17	24.84%
7	6.49	26.22%	6.20	25.25%	6.52	26.26%
11	4.26	17.20%	4.34	17.66%	4.41	17.77%
13	3.40	13.72%	2.89	11.75%	3.27	13.18%
17	4.13	16.69%	4.31	17.55%	4.34	17.49%
Total THD (%)	46.62%		46.12%		47.25%	
With Mitigation Device						
Order	L1		L2		L3	
	amps	% Distortion	amps	% Distortion	amps	% Distortion
1	22.79		22.45		22.78	
5	0.82	3.61%	0.58	2.58%	0.79	3.47%
7	0.54	2.36%	0.48	2.16%	0.42	1.86%
11	0.42	1.84%	0.47	2.07%	0.40	1.74%
13	0.27	1.20%	0.26	1.16%	0.26	1.16%
17	0.01	0.05%	0.00	0.02%	0.01	0.06%
Total THD (%)	4.95%		4.31%		4.66%	

Current Harmonic List — 50% Fan Speed						
Without Mitigation Device						
Order	L1		L2		L3	
	amps	% Distortion	amps	% Distortion	amps	% Distortion
1	6.40		6.06		6.45	
5	4.49	70.28%	4.33	71.45%	4.52	70.15%
7	3.74	58.53%	3.62	59.77%	4.02	62.32%
11	2.04	31.89%	2.04	33.58%	2.04	31.57%
13	1.23	19.20%	1.36	22.47%	1.42	21.96%
17	1.61	25.22%	1.53	25.31%	1.30	20.22%
Total THD (%)	119.97%		121.86%		123.98%	
With Mitigation Device						
Order	L1		L2		L3	
	amps	% Distortion	amps	% Distortion	amps	% Distortion
1	7.47		7.42		7.32	
5	0.32	4.35%	0.24	3.22%	0.32	4.38%
7	0.48	6.45%	0.50	6.72%	0.50	6.82%
11	0.24	3.17%	0.24	3.27%	0.24	3.27%
13	0.07	0.95%	0.07	0.99%	0.07	1.01%
17	0.03	0.39%	0.03	0.39%	0.03	0.35%
Total THD (%)	9.06%		8.88%		9.39%	

NOTE: Values shown at 50% fan speed are for reference only. At low demand, THD values will have a lower impact on the system than at full load.

UNIT TO UNIT NETWORK CONNECTIONS

LIEBERT® CW, LIEBERT® CWA, LIEBERT® DS, LIEBERT® DSE,
LIEBERT® PDX, LIEBERT® PCW

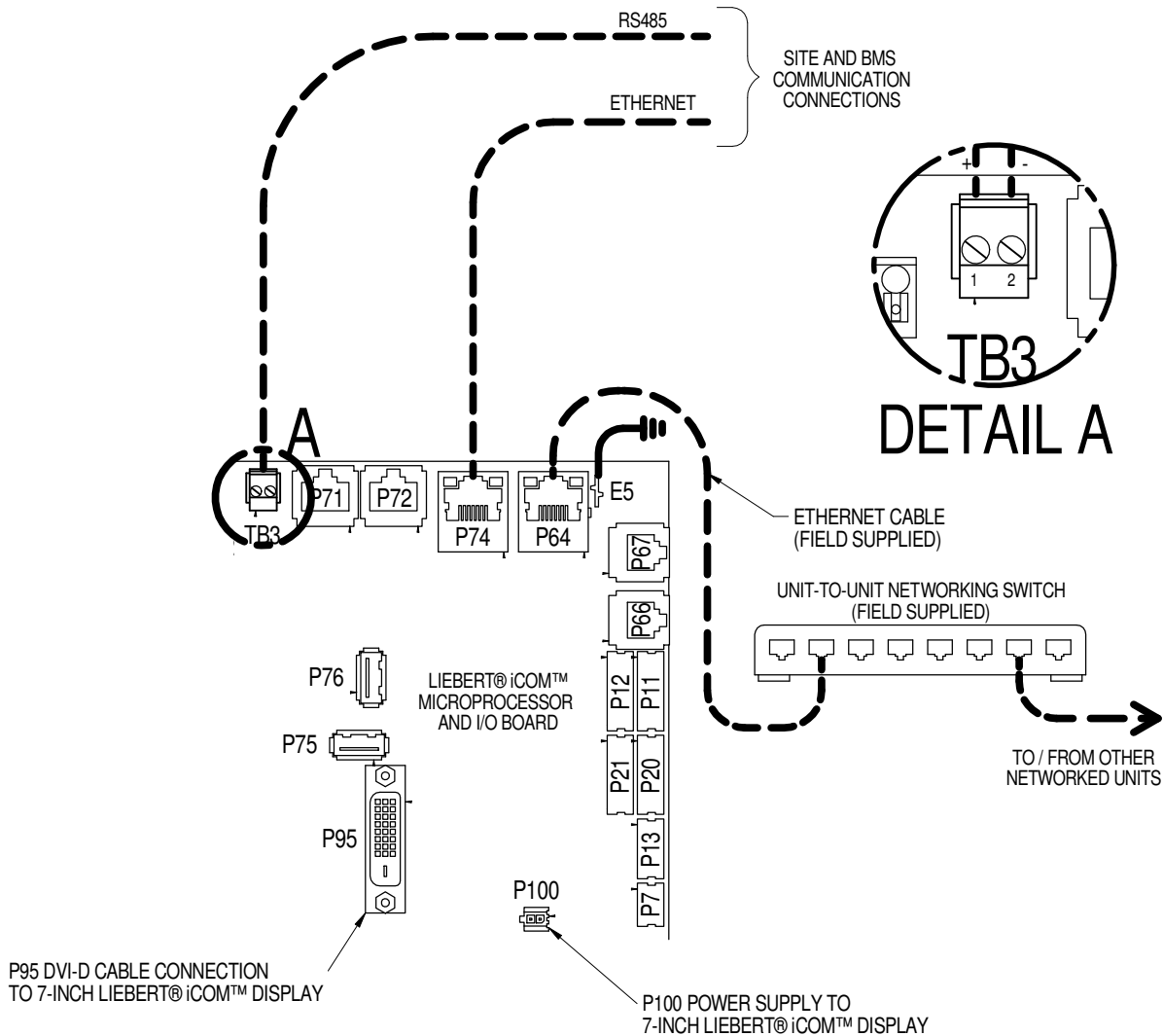

UNIT TO UNIT NETWORK CONNECTIONS

LIEBERT® CW, LIEBERT® CWA, LIEBERT® DS, LIEBERT® DSE,
LIEBERT® PDX, LIEBERT® PCW

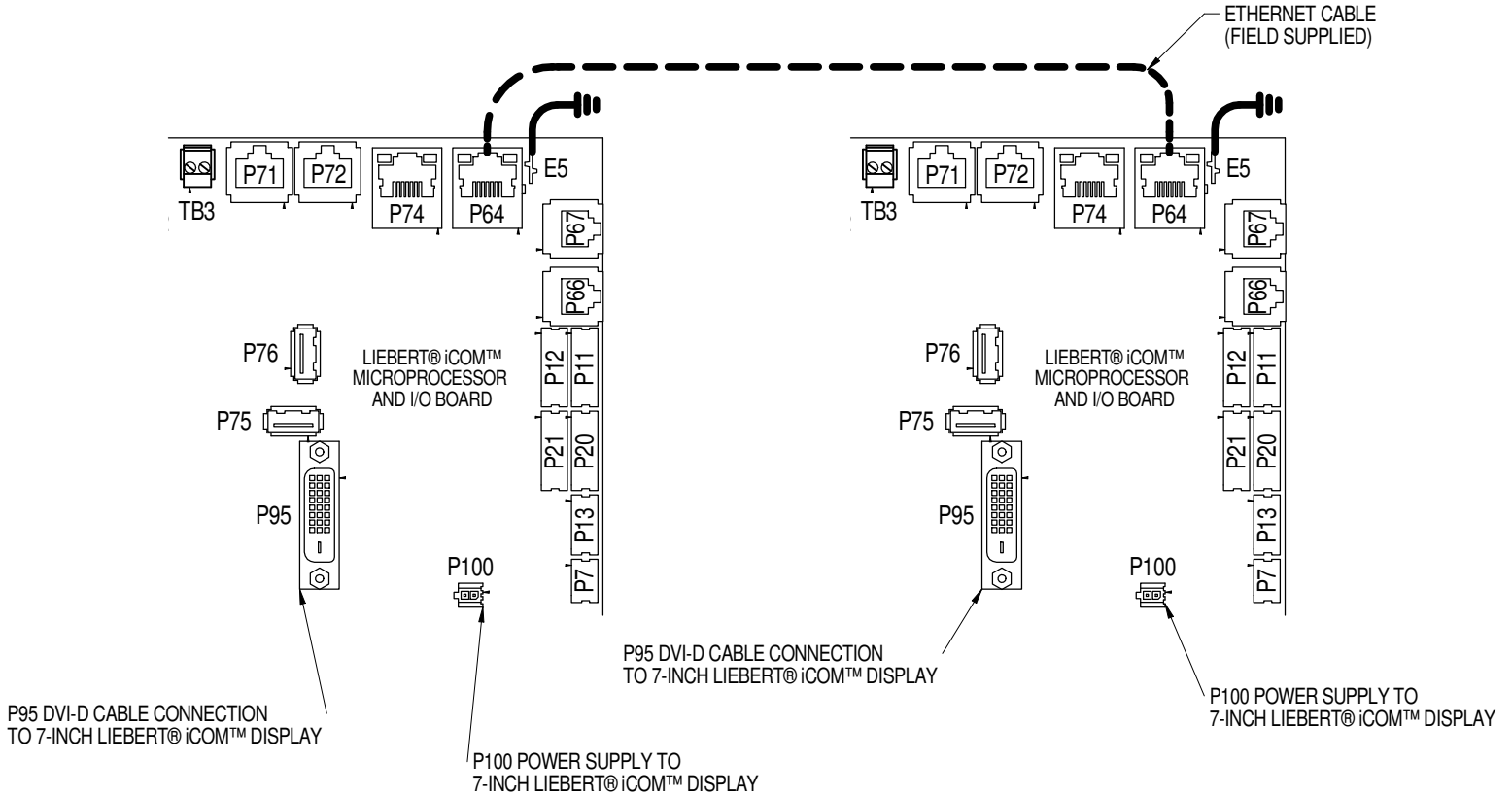

NOTE* For dual-unit network configurations only

**2T RACK TEMPERATURE SENSOR CONNECTIONS
LIEBERT® CW, LIEBERT® CWA, LIEBERT® DS, LIEBERT® DSE,
& LIEBERT® PDX UNITS**

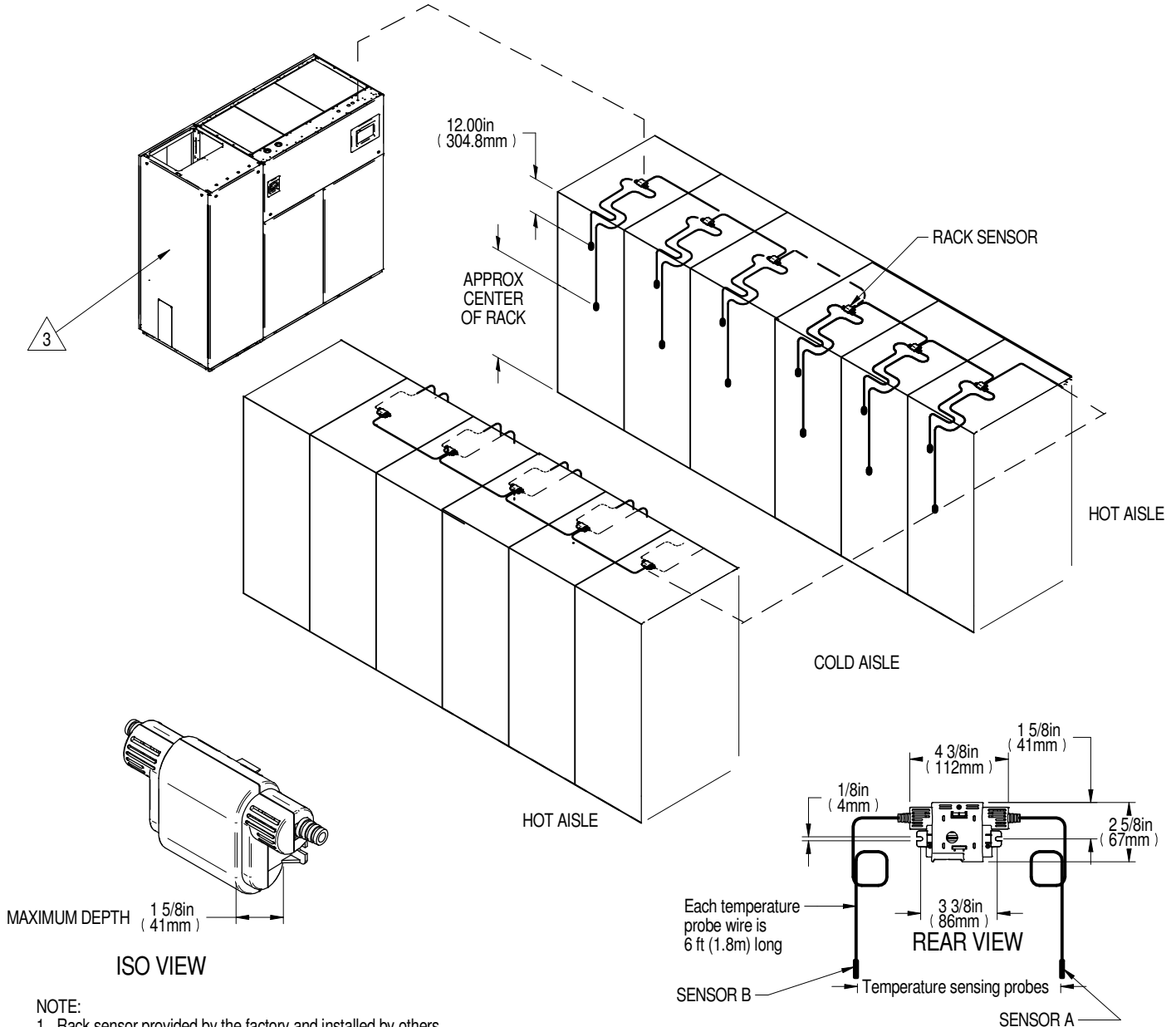

SEE INSTRUCTION SHEET 310301 FOR CANBUS WIRE CONSIDERATIONS AND SENSOR INSTALLATION INSTRUCTIONS.

REMOTE TEMPERATURE & HUMIDITY SENSOR

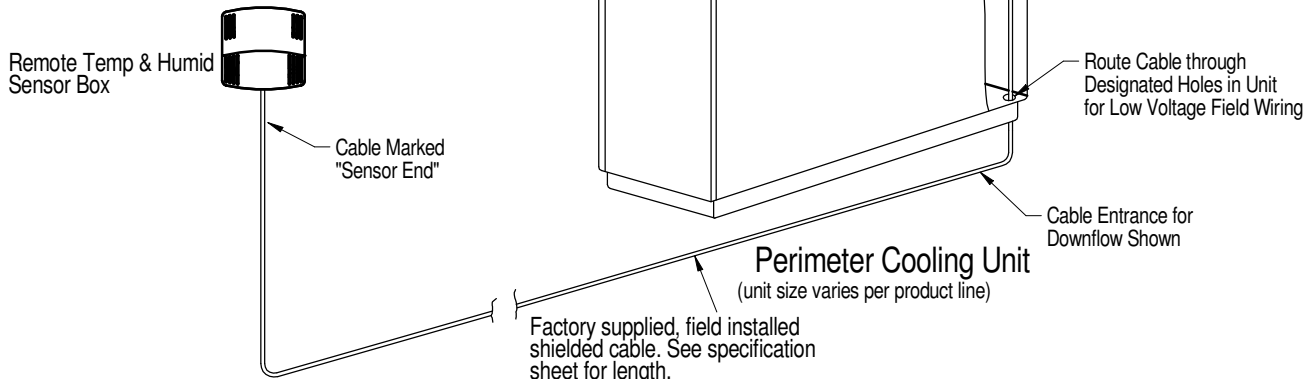
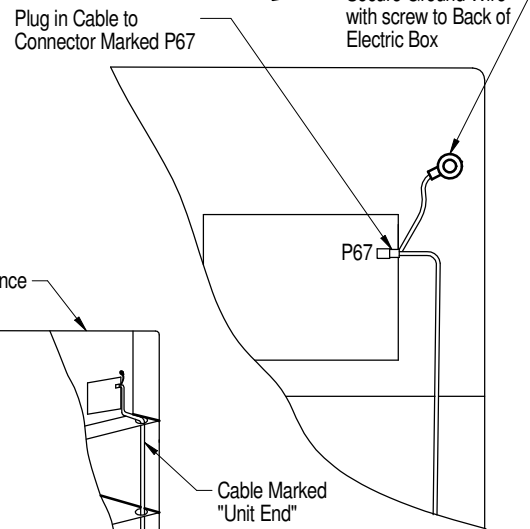
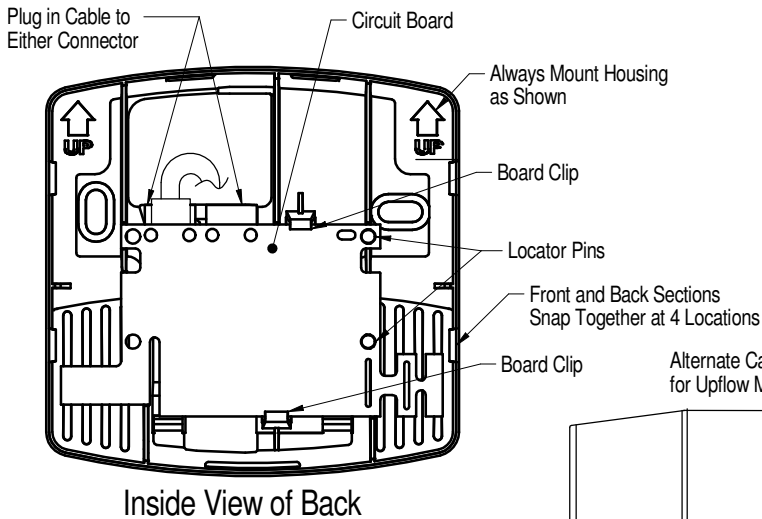
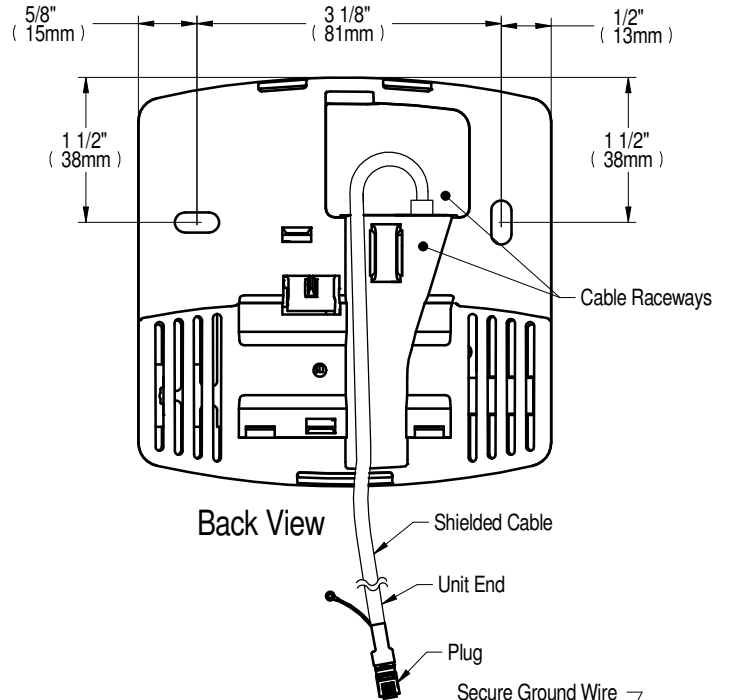
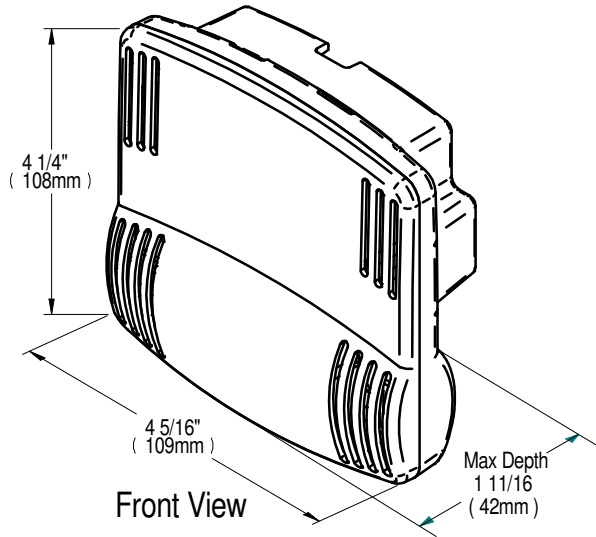

PRIMARY CONNECTION LOCATIONS WITH BRAZED CUSTOMER CONNECTIONS

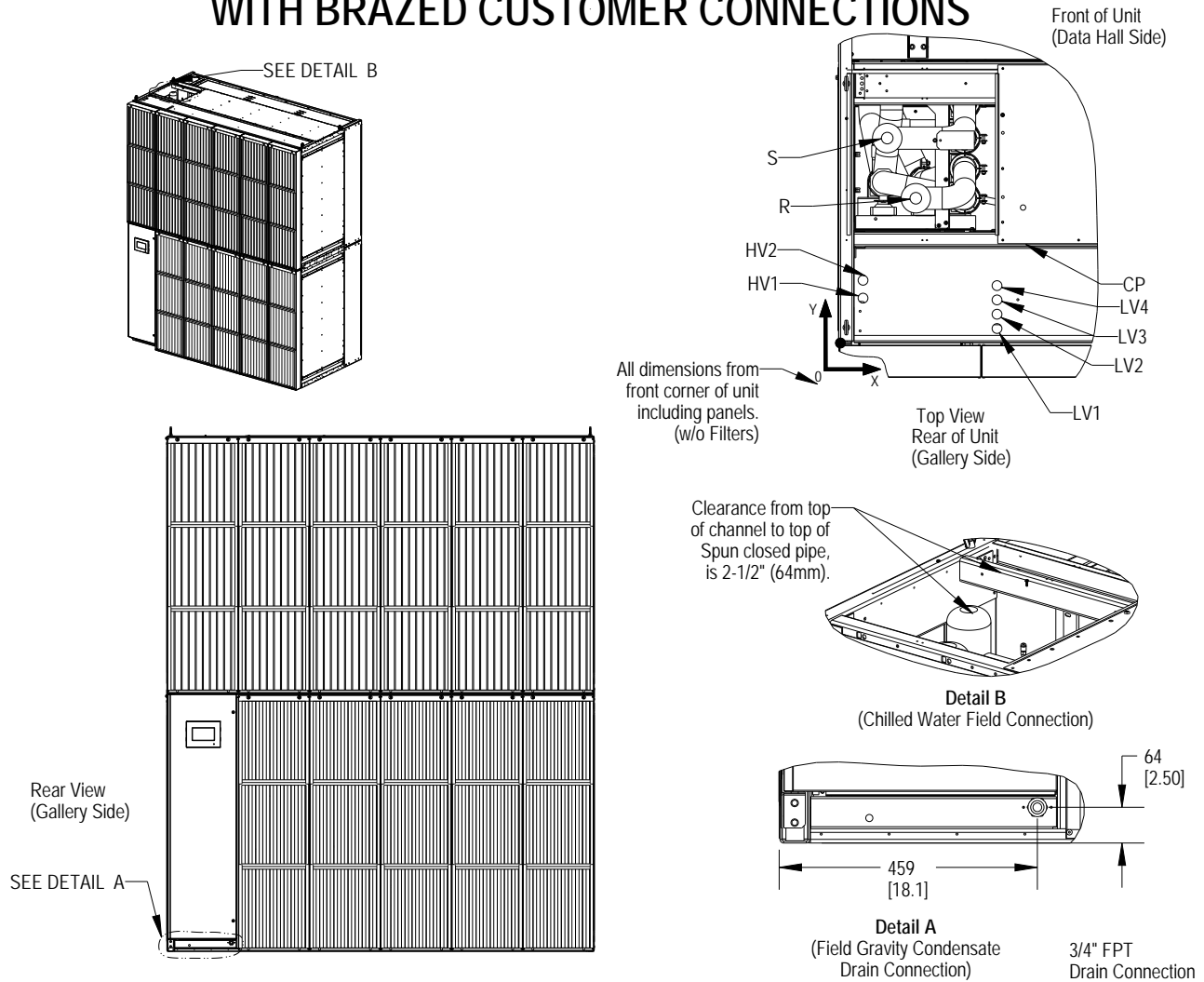

Connection	Description	X mm (in.)	Y mm (in.)	Connection Size Opening in.
R	Return Pipe Connection	274 (10.8)	513 (20.2)	4" O.D. CU
S	Supply Pipe Connection	173 (6.8)	726 (28.6)	
LV1	Electrical Connection (Low Volt)	564 (22.2)	51 (2.0)	1-3/8
LV2			102 (4.0)	
LV3			152 (6.0)	
LV4			203 (8.0)	
HV1	Electrical Connection (High Volt)	86 (3.4)	157 (6.2)	1-3/8
HV2			221 (8.7)	
CP	Condensate Pump Connection	655 (25.8)	480 (18.9)	1/2" O.D. CU

Notes:

1. Drawing not to scale. All dimensions from left corner on Gallery Side and have a tolerance of $\pm 1/2"$ (13mm).
2. The factory unit does not contain a trap. The drain must comply with all local codes. Select appropriate drain system materials. Field pitch Condensate Drain line a minimum 1/8" (3mm) per 12" (305mm).
3. Piping connection can be made at the top of the unit.

PRIMARY CONNECTION LOCATIONS WITH BRAZED CUSTOMER CONNECTIONS CHILLED WATER COIL DRAIN DETAIL

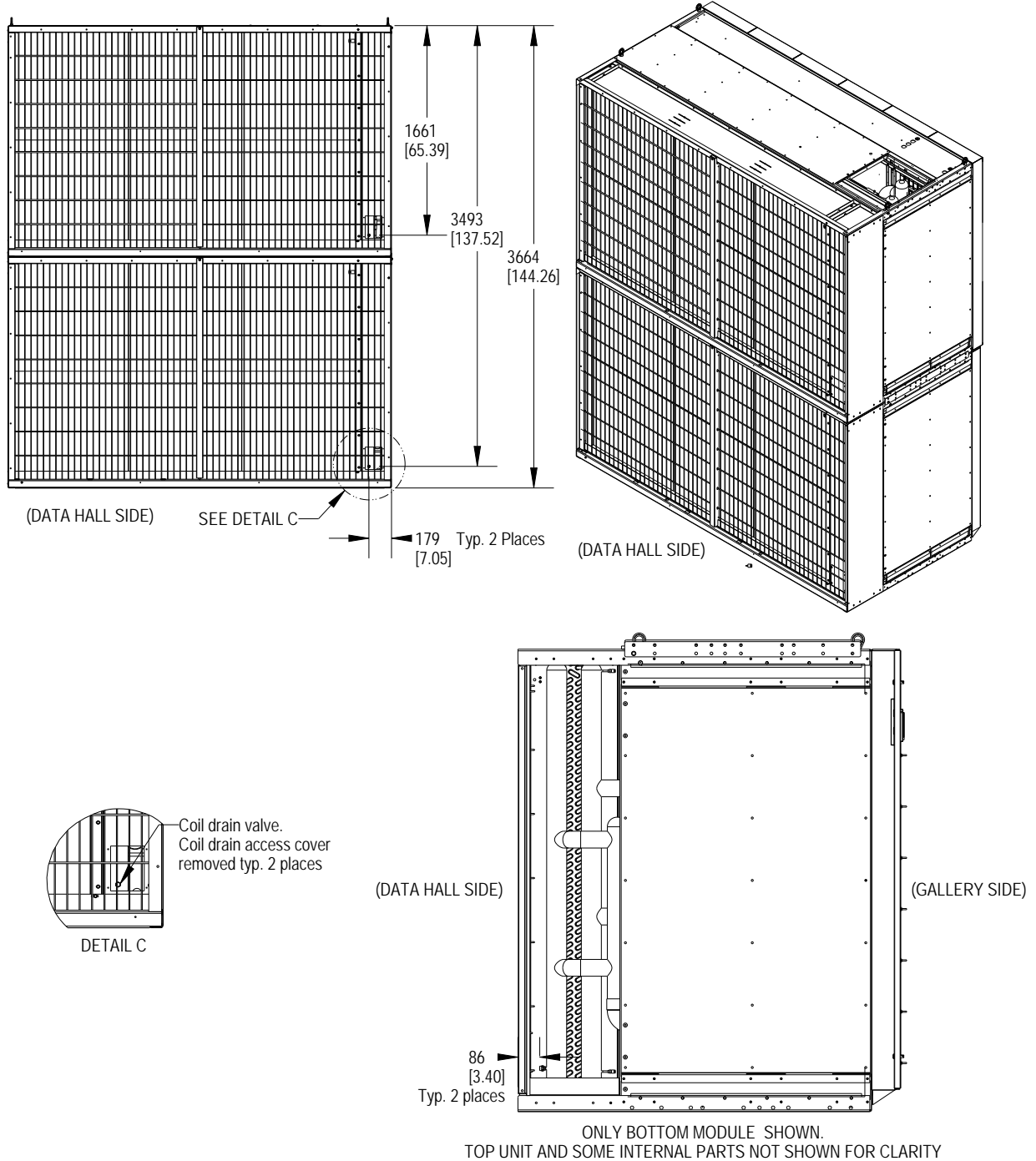

Notes:
1. Drawing not to scale.

PRIMARY CONNECTION LOCATIONS WITH FLANGED CUSTOMER CONNECTIONS

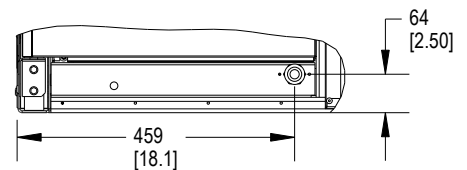
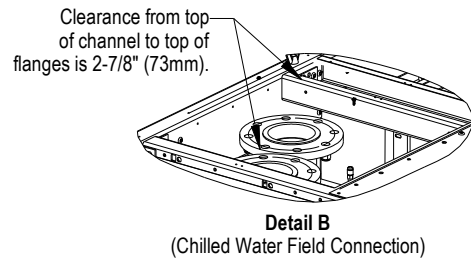
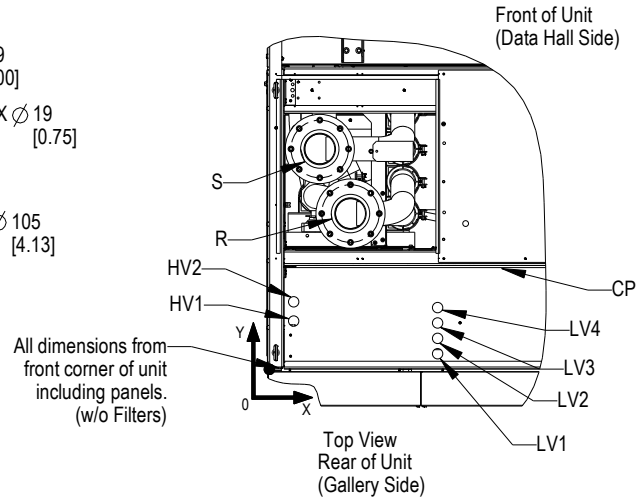
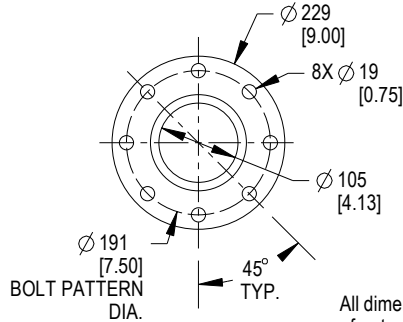
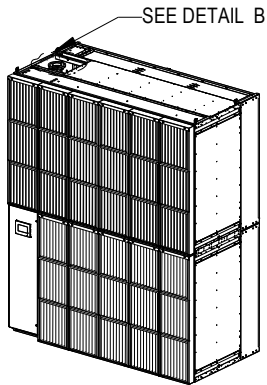

Detail A
(Field Gravity Condensate Drain Connection)

3/4" FPT Drain Connection

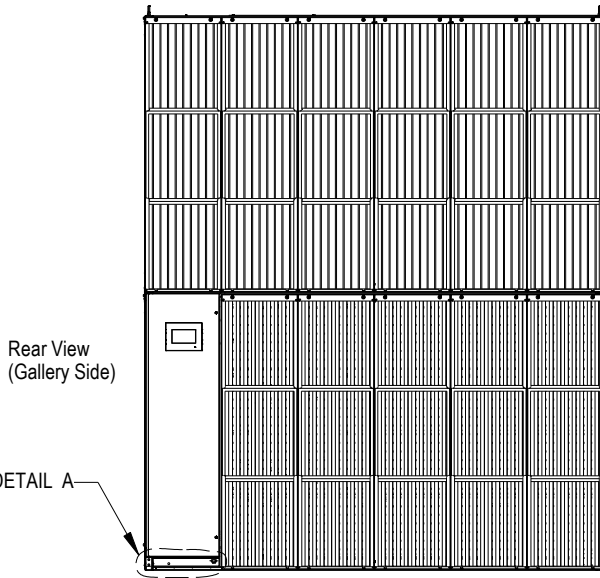

Connection	Description	X mm (in.)	Y mm (in.)	Connection Size Opening in.
R	Return Pipe Connection	274 (10.8)	513 (20.2)	4" WF-150 Style Flat Flange
S	Supply Pipe Connection	175 (6.9)	727 (28.6)	
LV1	Electrical Connection (Low Volt)	564 (22.2)	51 (2.0)	1-3/8
LV2			102 (4.0)	
LV3			152 (6.0)	
LV4			203 (8.0)	
HV1	Electrical Connection (High Volt)	86 (3.4)	157 (6.2)	
HV2			221 (8.7)	
CP	Condensate Pump Connection	655 (25.8)	480 (18.9)	1/2" O.D. CU

Notes:

- Drawing not to scale. All dimensions from left corner on Gallery Side and **have a tolerance of ±1/2" (13mm)**.
- The factory unit does not contain a trap. The drain must comply with all local codes. Select appropriate drain system materials. Field pitch Condensate Drain line a minimum 1/8" (3mm) per 12" (305mm).
- Piping connection can be made at the top of the unit.

PRIMARY CONNECTION LOCATIONS WITH FLANGED CUSTOMER CONNECTIONS CHILLED WATER COIL DRAIN DETAIL

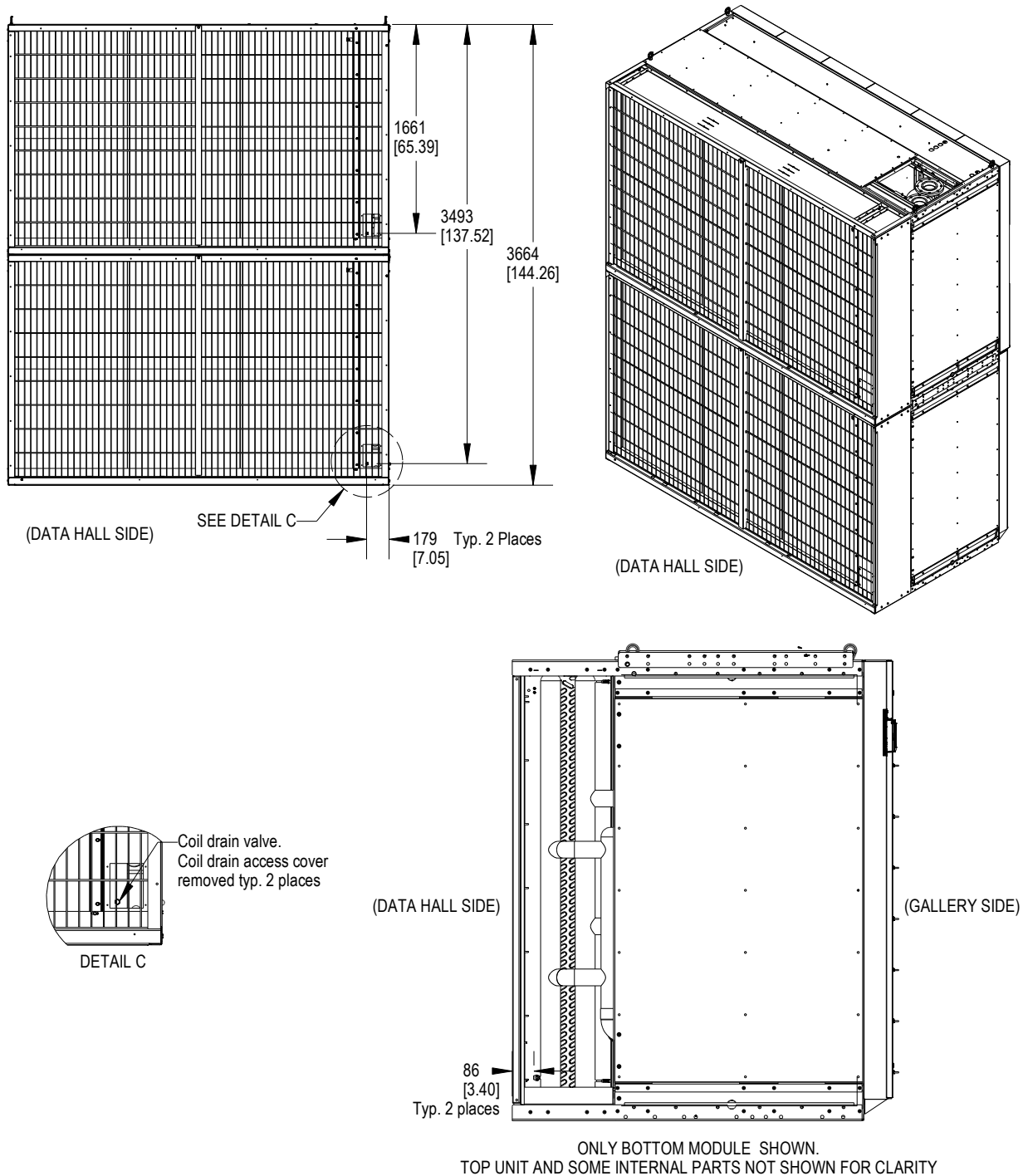

Notes:
1. Drawing not to scale.

**TOP AND BOTTOM ASSEMBLY
INTERNAL CONDENSATE DRAIN LINE CONNECTION**

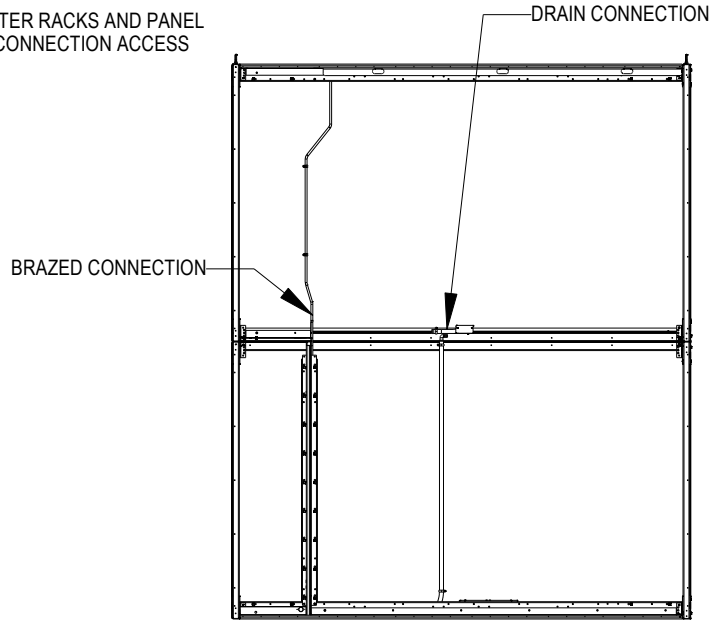
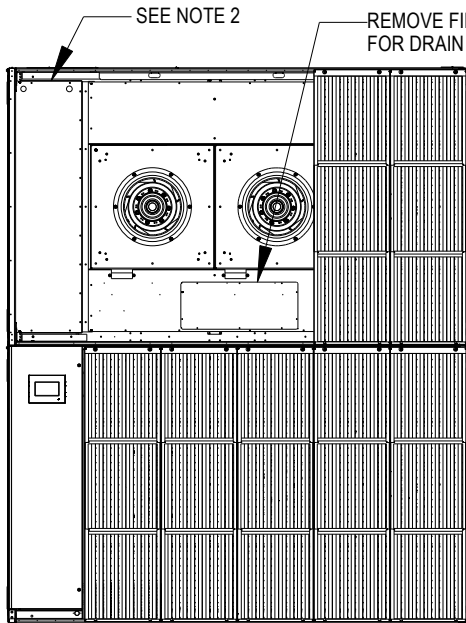

DRAIN LINE ROUTING
FRAME SHOWN FOR REFERENCE. SOME MEMBERS HIDDEN FOR CLARITY

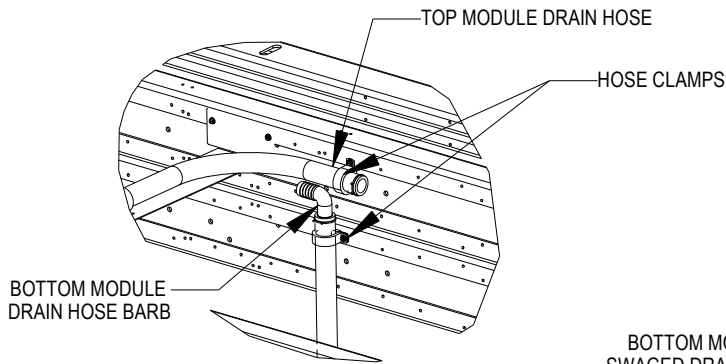

INTERNAL DRAIN CONNECTION
SEE NOTE 1 FOR DRAIN CONNECTION DETAILS

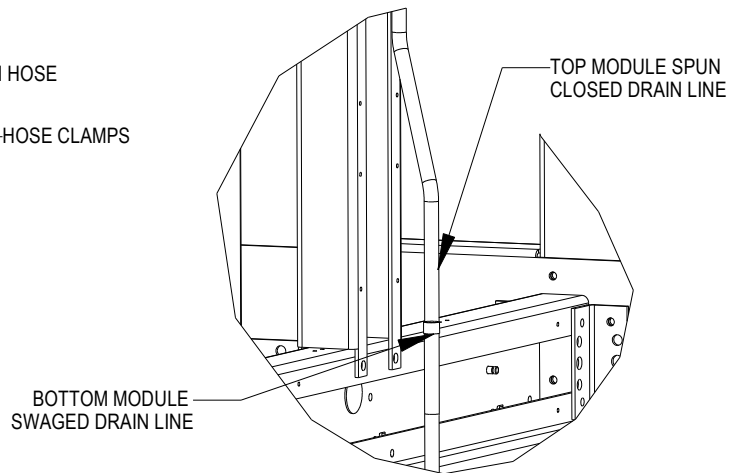

INTERNAL BRAZED CONNECTION FOR CONDENSATE PUMPS
SEE NOTE 3 FOR DRAIN CONNECTION DETAILS

NOTES:

1. REQUIRED FOR GRAVITY DRAIN AND CONDENSATE PUMP. INTERNAL CONNECTION MUST BE MADE BETWEEN TOP AND BOTTOM DRAIN HOSES. CUT HOSE TO LENGTH ON TOP MODULE AND ADJUST HOSE CLAMPS TO ENSURE PROPER SLOPE FOR DRAINAGE.
2. FOR CONDENSATE PUMP ONLY. REMOVE PANEL TO ACCESS BRAZED COPPER DRAIN CONNECTION.
3. REMOVE EXCESS COPPER ON SPUN CLOSED TOP MODULE DRAIN LINE. REMOVE PLUG ON BOTTOM MODULE COPPER DRAIN LINE. ENSURE COPPER IS CLEAN BEFORE BRAZING INTERNAL CONNECTION.

FIELD GRAVITY DRAIN CONNECTION

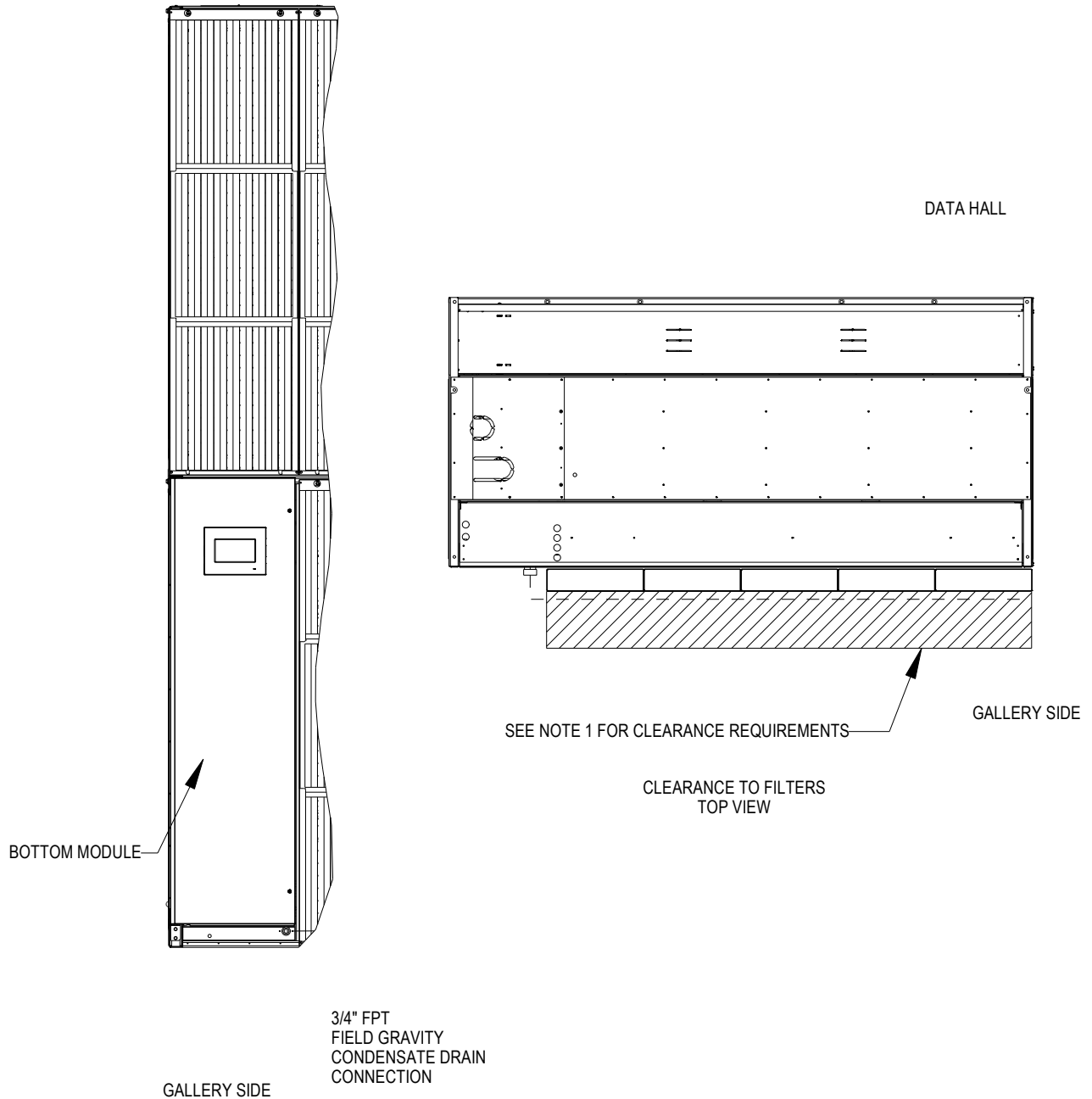

NOTES:

1.FOR EXTERNAL DRAIN CONNECTION ROUTED IN FRONT OF FILTERS, 101.6 [4.00"] MINIMUM CLEARANCE REQUIRED.



LIEBERT[®] CWA

BACKDRAFT BARRIER PLATE KIT Standard Axial Fan

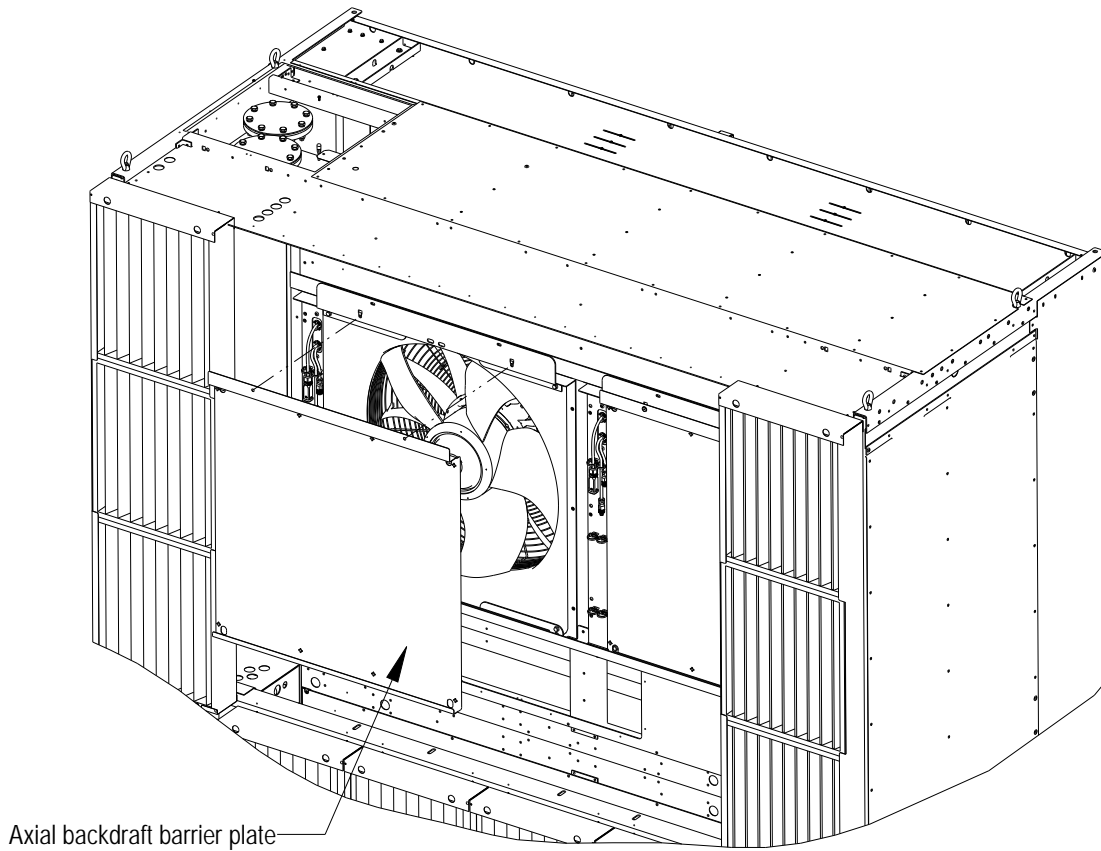

Backdraft Barrier Plate Kit for use with Standard Axial Fans shall be used to block airflow for unit or fan section not in operation. Kit includes two plates. Multiple quantities may be selected per desired application.



LIEBERT® CWA

BACKDRAFT BARRIER PLATE KIT High Airflow/High Efficiency Fan

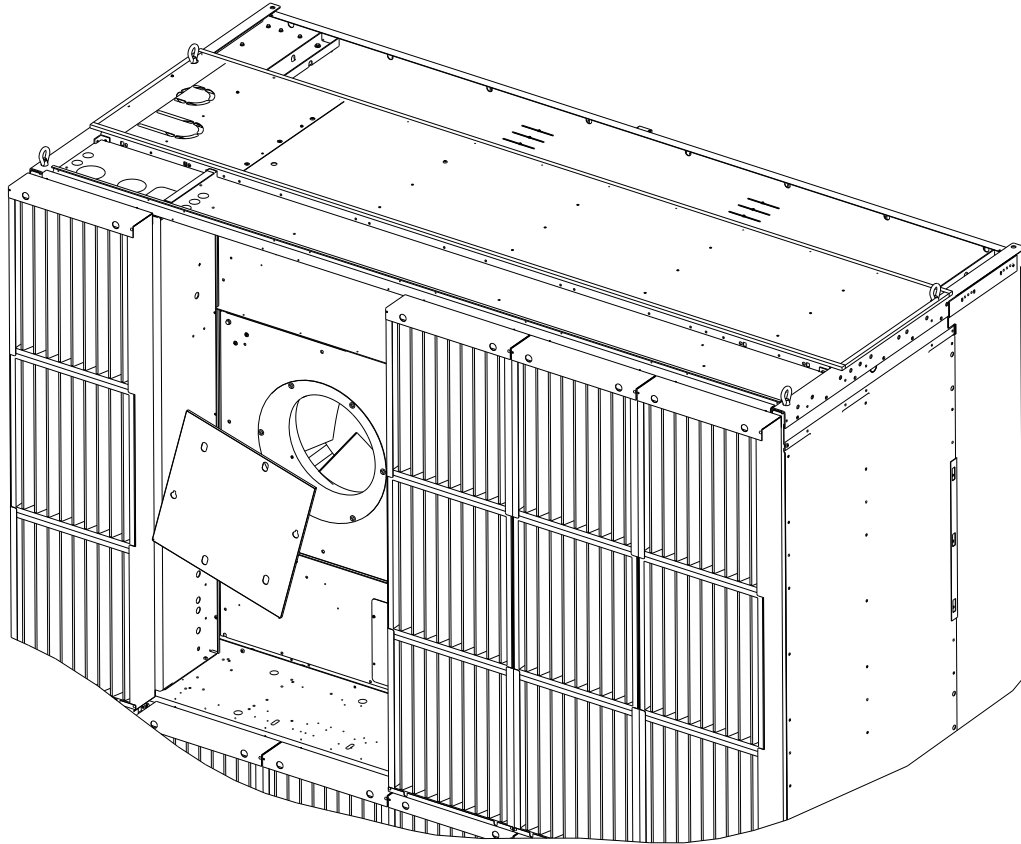

- Notes: 1. Backdraft Barrier Plate Kit for the High Airflow/High Efficiency fans shall be used to block airflow for unit or fan not in operation. Kit includes three plates
Multiple quantities may be ordered per desired application.
2. A Backdraft Barrier Plate Kit also exists for the High Airflow, or High Airflow/High Static fan option which utilizes a similar blocker plate design with some dimensional variance.

Appendix D: Seismic Application

Certification	IBC	
Internal Bracing Option	Factory Installed	
Unit	Sds	Ip
CA060 (Top and Bottom Module)	2.5	1.0

This page intentionally left blank

Appendix E: Guide Specifications

The following are the guide specifications for Vertiv™ Liebert® CWA.

Vertiv™ Liebert® CWA Thermal Wall Guide Specifications

1.0 GENERAL

1.1 Summary

These specifications describe requirements for a Thermal Management system. The system shall be designed to control temperature in rooms containing electronic equipment, with good insulation and vapor barrier. The manufacturer shall design and furnish all equipment to be fully compatible with heat dissipation requirements of the room.

1.2 Design Requirements

The Thermal Management system shall be a Liebert self-contained, factory assembled unit. Standard 60 Hz units shall be CSA-certified to the harmonized U.S. and Canadian product safety standard, "CSA C22.2 No 236/UL 1995 for Heating and Cooling Equipment" and are marked with the CSA c-us logo.

1.3 Submittals

Submittals shall be provided with the agreement of the proposal and shall include: Single Line Diagrams; Dimensional, Electrical and Capacity Data; Piping; and Electrical Connection Drawings.

1.4 Serviceability/Access

All service and maintenance shall be performed through the Gallery side of the unit, including any component removal (except the chilled water coil). No side access shall be required. All electrical and piping connections are made through the top of the unit.

1.5 Acceptable Alternatives

Acceptable alternatives shall be permitted with engineer's prior approval only. Contractor to submit a detailed summary form listing all variations to include size deviations, electrical load differences, functional and component changes, and savings to end user.

1.6 Quality Assurance

The specified system shall be factory-tested before shipment. Testing shall include but shall not be limited to: Quality Control Checks, "Hi-Pot." The system shall be designed and manufactured according to world-class quality standards.

2.0 PRODUCT

2.1 Cabinet Section

2.1.1 Frame

The unit frame section shall be constructed of 10-gauge and 12-gauge riveted structure.

2.1.2 Panels

Panels shall be powder painted steel with matte black finish. A hinged control access panel shall open to a second front panel which is a protective enclosure for all high voltage components.

2.1.3 Horizontal Air Discharge

The supply air shall exit from the front (data hall side) of the unit.

2.1.4 Discharge Grills

Discharge grills shall have mesh pattern 2" (51 mm) x 7.5" (191 mm) and chrome color.

2.1.5 Filters

The filter chamber shall be located on the gallery side of the chilled water coil cabinet. Filters shall be removable from the gallery side of the unit.

- **Filter Type, 4 in. MERV8 or MERV11**

Filters shall be deep pleated, 4" (102 mm) filters with an ASHRAE 52.2-2007 MERV8 or MERV11 rating.

- **Extra Filter Set**

____ extra set(s) of filters shall be provided per system.

- **Filter Clog**

The filter clog shall sound alarm when unit filters need to be changed (included with filter option).

2.2 Air Side/Fan Section

2.2.1 Standard Axial Fan

Standard Axial fans shall be integral direct driven and Electronically Commutated DC motors commonly referred to as an EC fan. The fan speed shall be variable and automatically regulated by the Vertiv™ Liebert® iCOM™ control through all modes of operation. The fans shall be located to blow air over the coil to ensure even air distribution and maximum coil performance. Fan motors shall be nominal 4.69 hp (3.5kW) each, with a maximum operating speed of 1200 rpm. (Quantity of 4, 2 fans in the top module and 2 fans in the bottom module.)

2.2.2 High Airflow, High Efficiency Fan—Optional

High airflow, high efficiency fans shall be Electronically Commutated DC motors commonly referred to as an EC fan. The fan speed shall be variable and automatically regulated by the Liebert® iCOM™ control through all modes of operation. The fans shall be located to blow air over the slab coil to ensure even air distribution and maximum coil performance. Fan motors shall be nominal 4.96 hp (3.70 kW) each, with a maximum operating speed of 1420 rpm. (Quantity of 6, 3 fans in the top module and 3 fans in the bottom module.)

2.3 Water Side/System Piping

2.3.1 Unit Water Circuit (Coil, Piping, and Valves)

Chilled water system, which includes bottom and top modules with coils, valves, and piping shall be designed for a maximum system water pressure of 270 PSIG (1861 kPa).

2.3.2 Chilled Water Coil

The chilled water coil shall be slab design for horizontal airflow and have 101.2 sq. ft. (9.4 sq. m) face area, ____ (4, 6, or 8) rows deep. It shall be constructed of copper tubes and aluminum fins with a maximum face velocity of ____ ft. per minute (____ m/s) at _____ CFM (____ CMH). A stainless-steel condensate drain pan shall be provided.

2.3.3 Chilled Water Control Valves

The water circuit shall include valves located in the top module: one valve for the top coil and one valve for the bottom coil. The motorized ball valves shall be modulating type that provide proportional control in response to room temperature and humidity as sensed by the microprocessor control. Valves shall be designed for up to 400 PSIG (2758 kPa) water pressure rating. Valve close-off pressure differential shall be 100 PSI (689 kPa). Transparent sight glasses shall be factory installed to allow for viewing of valve position.

2.3.4 Internal Piping Connections Between Modules

Internal Supply and Return Chilled Water Connections Between Modules

The Vertiv™ Liebert® CWA Top and Bottom modules shall be shipped with a holding charge of nitrogen. The supply and return piping that connect the top and bottom modules shall be field brazed connections.

Internal Condensate Connections Between Modules

The Liebert® CWA Top and Bottom module condensate drain hoses shall be connected in the field with factory provided hose clamps.

Internal Condensate Pump Piping Drain Line Connection Between Modules

The Liebert® CWA Top and Bottom module piping for optional condensate pump copper drain lines shall be field brazed together.

2.3.5 Customer Piping Connections

Customer Supply and Return Chilled Water Piping Connections

The supply and return chilled water connections shall be 4 in. OD CU and field brazed.

Flanged Customer Supply and Return Chilled Water Piping Connections - Optional

The optional, factory installed, supply and return chilled water flanged connections shall be 150 lb. Class steel pipe rated at 270 psi minimum to improve ease of customer connection to field supplied flanges and piping.

Condensate Customer Drain Connection

The factory provided condensate drain connection shall be ¾" FPT. Field to provide condensate drain from the unit per local code.

Condensate Pump Drain Connection

The factory provided condensate pump drain connection at the top of the unit shall be ½" OD CU. Field to provide connection per local code.

2.4 Electrical Components

2.4.1 Short Circuit Current Rating (SCCR)

The electrical panel shall provide at least 65,000A SCCR. Short circuit current rating (SCCR) is the maximum short circuit current a component or assembly can safely withstand when protected by a specific overcurrent protective device(s) or for a specified time.

2.4.2 Supply Air Sensor

The supply air temperature sensor shall provide real-time, direct feedback to the cooling unit to provide a consistent supply air temperature by adjusting the chilled water valve accordingly to maintain setpoint. The supply air temperature sensor will provide real-time monitoring of discharge air temperature on all other units.

2.4.3 Return Air Temperature and Humidity Sensors

The return air temperature and humidity sensor shall be included as standard on the Vertiv™ Liebert® CWA unit. Sensors are used for monitoring temperatures for safety and alarming purposes and may be used for optional unit control.

2.4.4 Common Alarm Contact Signal

One normally open type programmable common alarm is provided to interface user-selected alarms with a remote alarm monitoring device.

2.4.5 Remote Shutdown Terminal

The remote shutdown terminal shall provide the customer with a location to remotely shut down the unit, complying with the National Fire Code.

2.4.6 Locking Disconnect Switch

Locking Disconnect and Quick-Start Enabled

The locking type disconnect shall be a fused disconnect switch that can be accessed by opening the accent panel. Access to the high voltage electric panel compartment can be obtained only with the switch in the Off position. Fused disconnects are provided with a defeater button that allows access to the electrical panel when power is on.

Each Liebert® CWA shall have the Chilled Water Quick-Start feature enabled. After a loss of power, normally the Vertiv™ Liebert® iCOM™ control application takes approximately 60 seconds to reboot to allow the unit to provide airflow and cooling. Once the feature is enabled, the end user may configure a specific airflow output percent and cooling capacity output percent as desired. The unit shall operate at these configured values within approximately 10 seconds after a power restoration all while the Liebert® iCOM™ controller is rebooting. After the Liebert® iCOM™ has fully booted, the unit will continue normal operation.

Locking Disconnect, Quick-Start Enabled, and Capacitive Buffer—Optional

The locking type disconnect shall be a fused disconnect switch that can be accessed by opening the accent panel. Access to the high voltage electric panel compartment can be obtained only with the switch in the Off position. Fused disconnects are provided with a defeater button that allows access to the electrical panel when power is on.

Each Liebert® CWA shall have the Chilled Water Quick-Start feature enabled. After a loss of power, normally the Liebert® iCOM™ control application takes approximately 60 seconds to reboot to allow the unit to provide airflow and cooling. Once the feature is enabled, the end user may configure a specific airflow output percent and cooling capacity output percent as desired. The unit shall operate at these configured values within approximately 10 seconds after a power restoration all while the Liebert® iCOM™ controller is rebooting. After iCOM has fully booted, the unit will continue normal operation.

The unit shall be equipped with a capacitive buffer to provide the iCOM with a minimum of three minutes of ride-through power. The capacitive buffer shall provide power to the Liebert® iCOM™ control with embedded Unity functionality for continuous connectivity to Building Management System/Building Automation Systems (where applicable). This functionality is not available with valve configured for spring return closed.

Dual Locking Disconnects with ATS Control and Quick-Start Enabled—Optional

The Vertiv™ Liebert® CWA unit shall be provided with two manual locking disconnect switches. The locking type disconnects shall be fused disconnect switches that can be accessed by opening the accent panel. Access to the high voltage electric panel compartment can be obtained only with the switches in the Off position. Fused disconnects are provided with a defeater button that allows access to the electrical panel when power is on.

The unit shall include reversing starter with ATS (automatic transfer switch) control.

The ATS control will be capable of the following features:

- Determine if power is available in both primary and secondary sources.
- Allow for selection of which source is primary and which source is secondary.
- Ability to automatically switch from primary to secondary source, in the event of primary power loss.
- Ability to automatically switch secondary to primary source when primary power returns.
- Ability to remove unit from active power source if there is:
 - Voltage Imbalance
 - Phase Loss
 - Over/Under Voltage
 - Over/Under Frequency
- Capability for 3rd party interface monitoring and control

Vertiv™ Liebert® iCOM™ control will pull key information from the ATS control, allowing for easy interpretation of the current operation without needing to open the unit's front panel, potentially interrupting operation.

Each Liebert® CWA shall have the Chilled Water Quick Start feature enabled. After a loss of power, normally the iCOM control application takes approximately 60 seconds to reboot to allow the unit to provide airflow and cooling. Once the feature is enabled, the end user may configure a specific airflow output percent and cooling capacity output percent as desired. The unit shall operate at these configured values within approximately 10 seconds after a power restoration all while the iCOM controller is rebooting. After the iCOM has fully booted, the unit will continue normal operation.

Dual Locking Disconnect with ATS Control, Capacitive Buffer, and Quick-Start Enabled - Optional

The Liebert® CWA unit shall be provided with two manual locking disconnect switches. The locking type disconnects shall be fused disconnect switches that can be accessed by opening the accent panel. Access to the high voltage electric panel compartment can be obtained only with the switches in the Off position. Fused disconnects are provided with a defeater button that allows access to the electrical panel when power is on.

The unit shall include reversing starter with ATS (automatic transfer switch) control.

The ATS control will be capable of the following features:

- Determine if power is available in both primary and secondary sources.
- Allow for selection of which source is primary and which source is secondary.
- Ability to automatically switch from primary to secondary source, in the event of primary power loss.
- Ability to automatically switch secondary to primary source when primary power returns.
- Ability to remove unit from active power source if there is:
 - Voltage Imbalance
 - Phase Loss
 - Over/Under Voltage
 - Over/Under Frequency
- Capability for 3rd party interface monitoring and control

Vertiv™ Liebert® iCOM™ control will pull key information from the ATS control, allowing for easy interpretation of the current operation without needing to open the unit's front panel, potentially interrupting operation.

The unit shall be equipped with a capacitive buffer to provide the Liebert® iCOM™ with a minimum of three minutes of ride-through power. The capacitive buffer shall provide power to the Liebert® iCOM™ control with embedded Unity functionality for continuous connectivity to Building Management System/Building Automation Systems (where applicable). This functionality is not available with valve configured for spring return closed.

Each Vertiv™ Liebert® CWA shall have the Chilled Water Quick-Start feature enabled. After a loss of power, normally the iCOM control application takes approximately 60 seconds to reboot to allow the unit to provide airflow and cooling. Once the feature is enabled, the end user may configure a specific airflow output percent and cooling capacity output percent as desired. The unit shall operate at these configured values within approximately 10 seconds after a power restoration all while the iCOM controller is rebooting. After the iCOM has fully booted, the unit will continue normal operation.

3.0 CONTROLS

3.1 Vertiv™ Liebert® iCOM™ Microprocessor Control With 7 In. Color Touchscreen

The Liebert® iCOM™ shall be microprocessor based with a 7 in., high definition, capacitive, color touchscreen display and shall be mounted in an ergonomic, aesthetically pleasing housing. The display and housing shall be viewable while the front panel is open or closed. The controls shall be menu driven. The system shall display user menus for active alarms, event log, graphic data, unit view/status overview (including the monitoring of room conditions, operational status in percentage of each function, date and time), total run hours, various sensors, display setup, and service contacts. A password shall be required to make system changes. Service menus shall include setpoints, standby settings (lead/lag), timers/sleep mode, alarm setup, sensor calibration, maintenance/wellness settings, options setup, system/network setup, auxiliary boards, and diagnostics/service mode. The Liebert® iCOM™ control shall provide Ethernet/RS-485 ports dedicated for BMS connectivity (i.e. Base-Comms).

- **Password Protection**—The Liebert® iCOM™ shall contain two unique passwords to protect against unauthorized changes. An auto hide/show feature allows the user to see applicable information based on the login used.
- **Unit Backup and Restore**—The user shall be able to create safe copies of important control parameters. The Liebert® iCOM™ shall have the capacity for the user to automatically backup unit configuration settings to internal memory or USB storage drive. Configuration settings may be transferred to another unit for a more streamlined unit startup.
- **Parameter Download**—The Liebert® iCOM™ shall enable the user to download a report that lists parameter names, factory default settings and user-programmed settings in .csv format for remote reference.
- **Parameter Directory**—The Liebert® iCOM™ shall provide a directory that lists all parameters in the control. The list shall provide Line ID numbers, parameter labels, and current parameter values.
- **Parameter Search**—The Liebert® iCOM™ shall have search fields for efficient navigation and parameter lookup.
- **Context-Sensitive Help**—The Liebert® iCOM™ shall have an on-board help database. The database shall provide context sensitive help to assist with setup and navigation of the menus.
- **Display Setup**—The user shall have the ability to configure the Liebert® iCOM™ information based on the specific user's preference. Language, units of measure, screen contrast, home screen layout, backlight timer, and the hide/show of certain readouts shall be configurable through the display.
- **Additional Readouts**—The Liebert® iCOM™ shall permit the user to configure custom widgets on the main screen. Widget options shall include items such as fan speed, call for cooling, call for free cooling, maintenance status, call for hot water reheat, call for electric reheat, call for dehumidification, call for humidification, airflow, static pressure, fluid flow rate, and cooling capacity.
- **Status LEDs**—The Liebert® iCOM™ shall provide the user with the unit's operating status using an integrated LED. The LED shall indicate if the unit has an active alarm; if the unit has an active alarm that has been acknowledged; or if the unit is On, Off, or in standby status.
- **Event Log**—The Liebert® iCOM™ shall automatically store the last 400 unit only events (messages, warnings, and alarms).
- **Service Contact Information**—The Liebert® iCOM™ shall have the ability to store the local service or sales contact information.

- **Upgradeable**— Vertiv™ Liebert® iCOM™ firmware upgrades shall be performed through a USB connection.
- **Timers/Sleep Mode**—The menu shall allow various customer settings for turning on/off unit.
- **Menu Layout**—The menus shall be divided into two main menu screens: User and Service. The User screen shall contain the menus to access parameters required for basic unit control and setup. The Service screen shall be designed for service personal and provides access to advanced control setup features and diagnostic information.
- **Sensor Calibration**—The menus shall allow unit sensors to be calibrated with external sensors.
- **Maintenance/Wellness Settings** - The menus shall allow reporting of potential component problems before they occur.
- **Options Setup**—The menus shall provide operation settings for the installed components.
- **Auxiliary Boards**—The menus shall allow setup of optional expansion boards.
- **Various Sensors**—The menus shall allow setup and display of optional custom sensors. The control shall include four customer-accessible analog inputs for field-provided sensors. The analog inputs shall accept a 4 to 20mA signal. The user shall be able to change the input to 0 to 5VDC or 0 to 10VDC. The gains for each analog input shall be programmable from the front display. The analog inputs shall be able to be monitored from the front display.
- **Diagnostics/Service Mode**—The Liebert® iCOM™ shall be provided with self-diagnostics to aid in troubleshooting. The microcontroller board shall be diagnosed and reported as pass/not pass. Control inputs shall be indicated as On or Off at the front display. Control outputs shall be able to be turned On or Off from the front display without using jumpers or a service terminal. Each control output shall be indicated by an LED on a circuit board.
- **Base-Comms for BMS Connectivity**—The Liebert® iCOM™ controller shall provide one Ethernet Port and RS-485 Port dedicated for BMS Connectivity. Provides ground fault isolated RS-485 Modbus, BACnet IP and Modbus IP network connectivity to Building Management Systems for unit monitoring and management. Also, provides ground fault isolated 10/100 baseT Ethernet connectivity for unit monitoring and management. The supported management interfaces include SNMP for Network Management Systems, HTTP for web page viewing, SMTP for email, and SMS for mobile messaging. The Liebert® iCOM™ controller can support dual IP on a single network and one 485 protocol simultaneously.

3.2 Alarms

All unit alarms shall be annunciated through both audio and visual cues, clearly displayed on the screen, automatically recorded in the event log and communicated to the customer's Building Management System/Building Automation System. The iCOM shall activate an audible and visual alarm in the event of any of the following conditions:

- High Temperature
- Low Temperature
- High Humidity
- Low Humidity
- Fan Fault
- Change Filters
- Loss of Air Flow

- Loss of Power
- Custom Alarms

Custom alarm inputs shall be provided to indicate facility-specific events. Custom alarms can be identified with programmable labels. Frequently used alarm inputs shall include:

- Leak Under Floor
- Smoke Detected
- Standby Unit On

Each alarm (unit and custom) shall be separately enabled or disabled, selected to activate the common alarm and programmed for a delay of 0 to 255 seconds.

3.3 iCOM Control Methods And Options

The Vertiv™ Liebert® iCOM™ shall be factory set to allow precise monitoring and control of the condition of the air entering and leaving the unit. This control shall include predictive methods to control air flow and cooling capacity-based control sensors installed. Proportional and Tunable PID shall also be user-selectable options.

3.3.1 Controlling Sensor Options

The Liebert® iCOM™ shall be flexible in the sense that it shall allow controlling the capacity and fan from multiple different sensor selections. The sensor selections shall be:

- Cooling Capacity
 - Supply
 - Remote
 - Return
- Fan Speed
 - Supply
 - Remote
 - Return
 - Manual (for diagnostics or to receive a signal from the BMS through Liebert remote monitoring devices or analog input)
 - Static Pressure

3.3.2 Temperature Compensation

The Liebert® iCOM™ shall have the ability to adjust the capacity output based on supply and return temperature conditions to meet SLA guidelines while operating to highest efficiency.

3.4 Multi-Unit Coordination

Liebert® iCOM™ teamwork shall save energy by preventing multiple units in an area from operating in opposing modes. Teamwork allows the control to optimize a group of connected equipped with Liebert® iCOM™ using the U2U (Unit to Unit) network. There shall be three modes of teamwork operation:

- **Teamwork Mode 1 (Parallel):** Is best in small rooms with balanced heat loads. The controlling temperature and humidity sensor readings of all units in operation (fan On) are collected to be used for an average or worst-case sensor reading (user selectable). The master unit shall send the operating requirements to all operating units in the group. The control band (temperature, fan, and humidity) is derived and shared among the units in the group. Each unit will receive instructions on how to operate from the Master unit based on how far the system deviates from the setpoints. Evaporator fans and cooling capacity are ramped in parallel.
- **Teamwork Mode 2 (Independent):** The Vertiv™ Liebert® iCOM™ calculates the worse-case demand for heating, cooling humidification and dehumidification. Based on the greatest demand within the group, each unit operates independently, meaning that the unit may respond to the thermal load and humidity conditions based on the units controlling sensors. All sensor readings are shared.
- **Teamwork Mode 3: Optimized Aisle (Optimized Aisle):** May be applied in large and small rooms with varying heat loads. Optimized Aisle is the most efficient teamwork mode that allows the unit to match cooling capacity with heat load. In the Optimized Aisle mode, the fans operate in parallel. Fans can be controlled exclusively by remote temperature or using static pressure with a secondary remote temperature sensor(s) as an override to ensure that the inlet rack temperature is being met. Cooling (Compressors, Vertiv™ Liebert® Economizer or Vertiv™ Liebert® EconoPhase) is controlled by off unit supply air conditions. The Liebert® iCOM™ calculates the average or worst-case sensor reading (user selectable) for heating, cooling, humidification, and dehumidification. Based on the demand within the group, units will be allowed to operate within that mode until room conditions are satisfied. This is the best form of control for a room with an unbalanced load.

3.5 Standby/Lead-Lag

The Liebert® iCOM™ shall allow planned rotation to keep equal run time on units and provide automated emergency rotation of operating and standby units.

3.6 Standby Unit Cascading

The Liebert® iCOM™ cascade option shall allow the units to turn On and Off based on heat load when utilizing Teamwork Mode 3–Optimized Aisle mode with remote temperature sensors. In Teamwork Mode 3, Cascade mode will stage units On based on the temperature and humidity readings and their deviation from setpoint. Cascade mode coordinates the fan speed dynamically to save energy and to meet cooling demands. For instance, with a iCOM group of six units and only 50% of the heat load, the iCOM shall operate only four units at 80% fan speed and leave the other two units in standby. As the heat load increases, the iCOM shall automatically respond to the new load and bring on another unit, increasing the units in operation to five. As the heat load shifts up or down, the control shall meet the needs by cascading units On or putting them back into standby.

3.7 Virtual Master

As part of the robust architecture of the Liebert® iCOM™ control, it shall allow for a virtual master that coordinates operation. The Virtual Master function shall provide smooth control operation if the group's communication is compromised. When the lead unit which is in charge of component staging in teamwork, unit staging, and standby rotation becomes disconnected from the network, the Liebert® iCOM™ automatically assigns a virtual master. The virtual master shall assume the same responsibilities as the master until communication is restored.

3.8 Virtual Back-Draft Damper

The Liebert® iCOM™ shall allow the use of a virtual backdraft damper, eliminating the need for a mechanical damper. This shall allow the fans of a stand-by unit to spin in reverse at a low speed (15% or less) to act as a damper.

3.9 Wired Supply Sensor

Each iCOM shall have one factory supplied and connected supply air sensor that may be used as a controlling sensor or reference. When multiple sensors are applied for control purposes, the user shall be able to control based on a maximum or average temperature reading.

3.10 System Auto Restart

The auto restart feature shall automatically restart the system after a power failure. Time delay shall be programmable. An optional capacitive buffer may be provided for continuous control operation through a power outage.

3.11 Sequential Load Activation

On initial startup or restart after power failure, each operational load shall be sequenced with a minimum of one second delay to minimize total inrush current.

3.12 CW Quick-Start

Each Vertiv™ Liebert® CWA shall have the Chilled Water Quick-Start feature enabled. After a loss of power, normally the iCOM control application takes approximately 60 seconds to reboot to allow the unit to provide airflow and cooling if Quick-Start feature is not enabled. Once the feature is enabled, the end user may configure a specific airflow output percent and cooling capacity output percent, as desired. The unit shall operate at these configured values within approximately 10 seconds after a power restoration all while the iCOM controller is rebooting. After Vertiv™ Liebert® iCOM™ has fully booted, the unit will continue normal operation.

3.13 Adaptive PID - CW Auto-Tuning

Liebert® iCOM™ shall support the use of Liebert's auto-tuning feature called Adaptive PID. Adaptive PID may be used for fan speed control or cooling capacity control. With Adaptive PID selected, Liebert® iCOM™ shall automatically recognize oscillations across multiple subsystems relating to the PI tuning associated with either mode of control and correct those oscillations with zero human intervention. This feature allows for better overall system operation and responds well to increasing/decreasing system load.

3.14 Supply Sensor Aggregation

Each Liebert® iCOM™ controller shall support the Supply Sensor Aggregation feature. Supply Sensor Aggregation allows for the use of additional remote 2T temperature sensors that are used to calculate an aggregated supply air temperature value which may be used for cooling capacity control. Each Liebert® iCOM™ controller can support up to five additional remote 2T sensors for supply sensor aggregation. Sensors must be ordered separately and may be in addition to WIRED REMOTE 2T sensor application.

4.0 MISCELLANEOUS OPTIONS

4.1 IBC Seismic Bracing SDS 0.75 - Optional

The Vertiv™ Liebert® CWA cabinet shall include factory installed bracing, must be in compliance with IBC2018, CBC 2019, Ip 1.0 and Sds 0.75 requirements, based on third-party analytic certification. A certificate of compliance is available upon request. Unit must be installed per factory installation instructions to fully comply with certification. IBC Sds 0.75 Seismic Bracing option shall be compatible with units that have Standard Axial Fan or High Airflow, High Efficiency Fan.

4.2 IBC Seismic Bracing SDS 2.5 - Optional

The Liebert® CWA cabinet shall include factory installed bracing must be in compliance with IBC2018, CBC 2019, Ip 1.0 and Sds 2.5 requirements, based on third-party analytic certification. A certificate of compliance is available upon request. Unit must be installed per factory installation instructions to fully comply with certification. IBC Sds 2.5 Seismic Bracing option shall be compatible with units that have Standard Axial Fan or High Airflow, High Efficiency Fan.

4.3 Total Harmonic Distortion Transformer (THD) - Optional

The requirement for the internally mounted THD (total harmonic distortion) mitigation transformer is application dependent. It is highly recommended that start-up measurements be taken to determine if the current flow THD levels are acceptable. This option may be required if the Computer Room Air Conditioner units are on a back-up generator and the blower current is greater than 33% of the generator load current. The option may also be required if the EC blower load becomes a high percentage of the UPS rating (if units are on a UPS) or if the EC blower load becomes a large percentage of the utility service supply power in installations with a weak supply. THD Transformer shall be factory installed in Liebert® CWA unit.

4.4 Power Monitoring - Optional

The unit shall be equipped with factory-programmed/installed power meter to monitor power characteristics for either individual component or total unit. The power meter allows the user to monitor meter connection status, input under voltage, input RMS voltage leg-to-leg and leg-to ground, input current for each phase, energy consumption in kilowatt hours and instantaneous power in watts. In multi-unit applications, a phase loss protection routine shall place a unit into standby mode in the event that phase loss is detected.

4.5 Static Pressure Fan Control - Optional

A pressure transducer shall be factory installed in the unit and wired to an analog input on the Vertiv™ Liebert® iCOM™ control. The pressure ports on the transducer will be factory supplied with two sections of 50 ft. (15.2 m) tubing to be used for low and high side tubing with snubber installed close to the transducer on the high side. Tubing will be coiled and tied to the unit.

NOTE: Air probe is not provided.

4.6 Backdraft Barrier Plate Kit For Standard Axial Fan - Optional

Backdraft Barrier Plate Kit for use with Standard Axial Fans shall be used to block airflow for unit or fan section not in operation. Kit includes two plates. Multiple quantities may be selected per desired application.

4.7 Backdraft Barrier Plate Kit For High Airflow, High Efficiency Fan - Optional

Backdraft Barrier Plate Kit for use with High Airflow, High Efficiency Fans shall be used to block airflow for unit or fan section not in operation. Kit includes three plates. Multiple quantities may be selected per desired application.

4.8 Standard Axial Fan Handover Spares Kit - Optional

Standard Axial Fan Handover Spares Kit shall include critical spare parts (two Standard Axial Fans, fuses, Liebert® iCOM™ unit control board, and display) for 460V Liebert® CWA.

4.9 Standard Axial Fan (with THD Program) Handover Spares Kit - Optional

Standard Axial Fan Handover Spares Kit shall include critical spare parts (two Standard Axial Fans programmed for use with THD, fuses, Vertiv™ Liebert® iCOM™ unit control board, and display) for 460V Vertiv™ Liebert® CWA.

4.10 High Airflow, High Efficiency Fan Handover Spares Kit - Optional

High Airflow, High Efficiency Fan Handover Spares Kit shall include critical spare parts (two High Airflow, High Efficiency Fans, fuses, Liebert® iCOM™ unit control board, and display) for 460V Liebert® CWA.

4.11 High Airflow, High Efficiency Fan (with THD Program) Handover Spares Kit - Optional

High Airflow, High Efficiency Fan Handover Spares Kit shall include critical spare parts (two High Airflow, High Efficiency Fans programmed for use with THD, fuses, Liebert® iCOM™ unit control board and display) for 460V Liebert® CWA.

4.12 Gravity Condensate Connection Conversion Kit - Optional

Gravity Condensate Connection Conversion Kit shall include all parts necessary to alter the standard gravity drain of the Liebert® CWA to allow either right hand or left hand gravity condensate drain connection from the unit when viewed from the Gallery Side. Some components from the standard assembly must be used for the conversion connection.

4.13 High Temperature Sensor - Optional

This sensor shall be factory-installed in the unit and shall be factory set to 125°F (52°C). It shall immediately shut down the environmental control system when activated. The sensor shall be mounted with the sensing element in the return air. This sensor is not meant to replace any fire detection system that may be required by local or national codes.

4.14 Smoke Sensor - Optional

The smoke sensor samples the return air, shuts down the unit upon activation, and sends visual and audible alarms. Dry contacts are available for a remote customer alarm. The smoke sensor includes a "supervision" contact closure. This smoke sensor is not intended to function as or replace any room smoke detection system that may be required by local or national codes.

4.15 Condensate Pump, Dual Float - Optional

The condensate pump shall be complete with integral dual-float switch, pump, motor assembly, and reservoir. The secondary float shall send a signal to the Liebert® iCOM™, which will display the condensate pump alarm and shut down the unit upon high water condition. An additional dedicated normally open contact signal shall also be provided. The condensate pump shall be factory installed in the Liebert® CWA bottom module.

4.16 Remote Humidifier Contact - Optional

A pair of normally open contacts shall be provided for connection to a remote humidifier that allow the unit's humidity controller to control a humidifier outside the unit. Power to operate the remote humidifier does not come from the unit.

4.17 Remote Temperature And Humidity Sensors - Optional

Remote temperature and humidity sensor shall be provided in a vented case for mounting in the room to be conditioned. Includes 30 ft. (9m), 60 ft. (18m), 90 ft. (27m), 120 ft. (36m), or 150 ft. (45m) of cable supplied for connecting sensors to unit. Units are supplied without internal return air temperature and humidity sensors when remote sensor is selected.

4.18 Low Voltage Terminal Package - Optional

Factory-installed and factory-wired terminals shall be provided.

- **Remote Shutdown Terminals** - Two additional pairs of terminals provide the customer with additional locations to remotely shut-down the unit by field-installed devices or controls.
- **Extra Common-Alarm Contacts** - Two additional pairs of terminals provide the customer with normally-open contacts for remote indication of unit alarms.
- **Main-Fan Enabled Contact** - On Main Fan Enable, one set of normally-open contacts will close for remote indication of fan operation.
- **Vertiv™ Liebert® Liqui-Tect™ Shutdown** - 1 pair of dry contacts for the Liebert® Liqui-Tect™ sensor signal will provide unit shut down. (Liqui-Tect sensor is not included.)

4.19 LT460 Liebert® Liqui-Tect™ Sensor (Factory Installed) - Optional

LT460 Liebert® Liqui-Tect™ zone water sensor cable shall be factory wired and secured in the bottom of the Vertiv™ Liebert® CWA Bottom Module. The LT460 provides zone leak coverage within the bottom module by utilizing a leak detection cable. A cable termination sensor box is powered by 24 VAC from the Liebert® CWA unit with two Form-C dry contact common alarm relay outputs rated at 24 VAC, 3 Amp to remotely signal leak detected, loss of power and cable fault. The leak cable consists of a four-conductor cable, with two conductors being jacketed with CL2P rated covering. The two remaining conductors are covered with porous non-conductive polymers. The cable is UL-listed with a CL2P rating. The end of the cable is terminated in matching male and female connectors for easy connection of cables from end to end. Accuracy of the leak cable is linear and within 1% of the length of the cable.

4.20 Liebert® Liqui-Tect™ Sensors (Maximum Of 2 Per Unit) - Optional

Liqui-Tect sensor(s) model _____ shall be field installed and connected to Liebert® CWA unit. The water sensor is a hermetically sealed solid-state device with no moving parts. When the sensor detects the presence of moisture, the alarm system is activated.

____ (quantity) solid state water sensors shall be provided for installation.

4.21 Vertiv™ Liebert® vNSA Network Switch - Optional

The Liebert® vNSA network switch is designed for networking multiple iCOM unit-level controllers together. There shall be two different styles of the vNSA14 panel available:

- Liebert® vNSA14—enclosure with network switches only
- Liebert® vNSA14 iCOM™-H - enclosure with network switches and 9-in. iCOM color touchscreen display

Each offering shall be housed inside a steel enclosure secured with a key lock and contain two network switches, providing a total of 14 Ethernet ports available for iCOM controller unit-to-unit networking. The Liebert® vNSA requires field supplied, hard wiring, 16AWG, 100-240VAC universal (12V, 1.5A) single-phase input power supply for 120V or 230V operation with factory supplied power connector.

4.22 Remote 2T Sensor(s) - Optional

Remote 2T sensors may be used for remote monitoring and control application such as supply sensor aggregation. A maximum of 10 sensors for WIRED 2T and maximum of five for supply sensor application per unit.

As part of the U2U network, these WIRED 2T sensors shall be shared and used to control the cooling units and provide greater flexibility, visibility, and control to respond to changes in the conditioned space. When the sensors are used for control, the user may set the control to be based off a maximum or average of a selected highest temperature reading.

5.0 EXECUTION

5.1 Installation Of Thermal Management Units

The customer or the customer's representative shall be responsible for the following.

5.1.1 General

Install Thermal Management units in accordance with the manufacturer's installation instructions. Install units plumb and level, firmly anchored in locations indicated and maintain the manufacturer's recommended clearances.

5.1.2 Electrical Wiring

Install and connect electrical devices furnished by the manufacturer but not specified to be factory mounted. Furnish copy of the manufacturer's electrical connection diagram submittal to electrical contractor.

5.2 Piping Connections

Install and connect devices furnished by manufacturer but not specified to be factory mounted. Furnish copy of the manufacturer's piping connection diagram submittal to piping contractor.

5.2.1 Supply, Return, and Drain Water Piping

Connect water supply, water return, and drains to air conditioning unit. Provide pitch and trap as manufacturer's instructions and local codes require.

5.3 Field Quality Control

Start cooling units in accordance with the manufacturer's start-up instructions. Test controls and demonstrate compliance with requirements. These specifications describe requirements for a computer room environmental control system. The system shall be designed to maintain temperature and humidity conditions in the rooms containing electronic equipment.

The manufacturer shall design and furnish all equipment to be fully compatible with heat dissipation requirements.

5.3.1 Warranty Start-up and Control Programming

Install the indoor unit in accordance with manufacturer's installation instructions provided with seismic option. Firmly anchor maintaining manufacturer's recommended clearances. Mounting requirement details such as anchor brand, type, embedment depth, edge spacing, anchor-to-anchor spacing, concrete strength, special inspection and attachment to non-building structures must be outlined and approved by the Engineer of Record for the projection or building. Electrical, pipe, and duct connections must permit movement in three dimensions and isolate the unit from field connections. Electrical conduit shall be flexible, having at least one bend between the rigid connection at the unit cabinet and the connection to rigid conduit or foundation. The piping flexible connection or loop must be suitable for the operation pressure and temperature of the system. Furnish copy of manufacturer's piping connection diagram submittal to piping contractor.

Engage manufacturer's field service technician to provide warranty start-up supervision and assist in programming of unit(s) controls and ancillary panels supplied by them.

This page intentionally left blank

Connect with Vertiv on Social Media



<https://www.facebook.com/vertiv/>



<https://www.instagram.com/vertiv/>



<https://www.linkedin.com/company/vertiv/>



<https://www.twitter.com/Vertiv/>



Vertiv.com | Vertiv Headquarters, 505 N Cleveland Ave, Westerville, OH 43082 USA

© 2023 Vertiv Group Corp. All rights reserved. Vertiv™ and the Vertiv logo are trademarks or registered trademarks of Vertiv Group Corp. All other names and logos referred to are trade names, trademarks or registered trademarks of their respective owners. While every precaution has been taken to ensure accuracy and completeness here, Vertiv Group Corp. assumes no responsibility, and disclaims all liability, for damages resulting from use of this information or for any errors or omissions.

SL-70553_REV3_03-23